

doi: 10.3788/gzxb20164502.0206002

# 基于 LabVIEW 的光纤光栅自动检测及分析系统

刘春桐<sup>1</sup>, 李洪才<sup>1</sup>, 何祯鑫<sup>1</sup>, 吴国俊<sup>2</sup>

(1 第二炮兵工程大学, 西安 710025)

(2 中国科学院西安光学精密机械研究所, 西安 710119)

**摘 要:** 为了便于光纤布喇格光栅传感系统的自动化测试及使用, 利用光谱仪的远程控制端口, 采用 LabVIEW 语言开发了具有友好界面的 Q8384 光谱仪远程应力自动化测试系统. 将光纤布喇格光栅嵌入封装于钢梁中, 并利用应力试验机进行应力加载, 通过 LabVIEW 测试系统采集并处理实验数据, 结果表明该系统功能与设计预期吻合, 可以实现对被测量数据的实时监测及存储. 测试设备易于操作, 并且避免了对光谱仪的人为直接操作, 可以延长光谱仪的使用寿命.

**关键词:** 光纤光栅; 自动分析测试; 远程传感; LabVIEW

中图分类号: TP212; TN253

文献标识码: A

文章编号: 1004-4213(2016)02-0206002-7

## Design of Fiber Bragg Grating Automatic Analysis Test System Based on LabVIEW

LIU Chun-tong<sup>1</sup>, LI Hong-cai, HE Zhen-xin<sup>1</sup>, WU Guo-jun<sup>2</sup>

(1 the Second Artillery Engineering University, Xi'an 710025, China)

(2 Xi'an Institute of Optics and Precision Mechanics, Chinese Academy of Sciences, Xi'an 710119, China)

**Abstract:** For the purpose of realizing the Fiber Bragg Grating (FBG) sensing system automated test and analysis, a friendly interface of FBG sensing test system based on LabVIEW was designed by using the remote control port of Q8384 spectrometer. The strain/force integrated tester was used for tension test of a steel beam with embedded FBG packaged, the experiment data was acquired and analyzed by LabVIEW automatic testing platform, the results were in line with the design expectations, and the system realized the real-time monitoring and data storage capabilities. The tested device is easy to manage, and the direct operation on spectrometer is avoided, which can extend the service life of the spectrometer.

**Key words:** Fiber Bragg grating; Automatic analysis test; Remote Sensing; LabVIEW

**OCIS Codes:** 060.0060; 060.3738; 280.0280; 280.4788

## 0 Introduction

Fiber Bragg Grating (FBG) is one of the new optical fiber passive devices, which has great development in recent years<sup>[1-3]</sup>. As a kind of wavelength modulation fiber sensor, it has many incomparable advantages such as good dependability, anti-interference in electromagnetism, simple structure, multiplexing ability and distributed sensing,

etc. Compared to traditional electrical types of sensors, FBG has higher absolute measurement accuracy and other good characters, and is easy to reuse and composition sensor networks<sup>[4-6]</sup>. Therefore, FBG is widely considered to be one of the most promising ways of sensing<sup>[7-8]</sup>. FBG sensor is the wavelength encoding, which the measured physical quantity is modulated by the FBG sensor and become the changes of a FBG center wavelength<sup>[9]</sup>. Then, detecting the wavelength

**Foundation item:** Military Scientific Research Found(No. EP113075)

**First author:** LIU Chun-tong(1972-), male, professor, Ph. D. degree, mainly focuses on fiber Bragg grating sensing technology. Email: honghuang2009@163.com

**Received:** Mar. 2, 2015; **Accepted:** Oct. 26, 2015

<http://www.photon.ac.cn>

changes can measure the value of the measured physical quantity<sup>[10]</sup>. While the majority of FBG demodulation just measures the absolute wavelength and merely the wavelength display real-time by demodulation software within the devices, such as FBG temperature sensing<sup>[11]</sup>, strain sensing<sup>[12]</sup>, pressure sensing<sup>[13]</sup>, and structural health monitoring<sup>[14]</sup>, etc. In order to meet the needs of FBG sensing automatic detection, using the remote control port of Q8384 spectrometer, the FBG sensing demodulation software based on the LabVIEW development platform is prepared. Realizing the data acquisition and analysis of the FBG reflected wavelength and the spectrometer remote automation testing by the demodulation capabilities of Q8384, meanwhile, it can avoid the direct operating on the spectrometer and reduce operation errors, and extend the service life of the spectrometer.

## 1 Principle of FBG sensing and measuring system

FBG is holographic diffraction grating in optical fiber core writing by UV, as a phase grating, its core refractive index change is periodic distributions<sup>[15-16]</sup>. According to the coupled-mode theory, periodic disturbance index of refraction of FBG only have an impact on a very narrow spectrum for the broadband incident light, only the wavelength meet the condition as<sup>[17]</sup>

$$\lambda_B = 2n_{eff} \cdot \Lambda \quad (1)$$

Then the light wave can be reflected by the grating, the remaining transmission spectra are not affected, and FBG likes a mirror or filters work. In Eq. (1), the reflected center Bragg wavelength  $\lambda_B$  will change with the grating cycle  $\Lambda$  and the core of effective refractive index  $n_{eff}$  changes. The temperature and strain changes will cause changes in  $\Lambda$  and  $n_{eff}$ , so that the FBG is sensitive to temperature and strain. The temperature influences  $\lambda_B$  by thermo-optic effect and thermal expansion, and strain influences  $\lambda_B$  by elastic-optic effect and change grating period  $\Lambda$ , the drift of  $\lambda_B$  with strain and temperature is<sup>[18]</sup>

$$\Delta\lambda_B = K_T \cdot \Delta T + K_\epsilon \cdot \epsilon \quad (2)$$

where,  $K_T$ ,  $K_\epsilon$  are respectively the FBG strain and temperature sensitivity coefficient, and Eq. (2) is the analysis theoretical basis of the FBG sensing process. When FBG is in the external action of temperature and stress field, using the demodulation device to demodulate the Bragg wavelength, and the dynamic quantitative information of the field can be accurately obtained, this is the basic principle of the FBG sensor.

In FBG sensing system, the computer sends instructions to the spectrometer by the bus. According to the appropriate instructions, the spectrometer

completes the test work, then the test result is sent to the computer by bus, and the data analysis, display and processing functions are completed in the computer. The schematic diagram of the system is shown in Fig. 1, the Q8384 spectrometer in the system with General Purpose Interface Bus (GPIB), and the data acquisition card PCI-1670GPIB are from the Advantech Company.

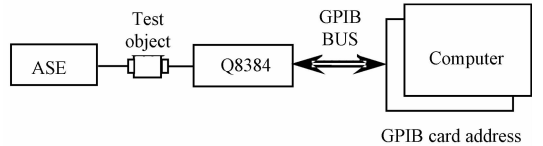

Fig. 1 Automatic test system for spectrometer

## 2 LabVIEW program and implementation

With the rapid development of the computer and instrument technology, universal, intelligent and networked test instruments and test systems, marked with virtual instrument, have developed rapidly, making the measurement instruments and methods of data acquisition system design and implementation have a profound change. It got rid of the method that constitutes a pattern of instrument and then constitutes the system by traditional hardware structure<sup>[11]</sup>. LabVIEW is the most widely used software environment which is developed by the National Instrument Company (NI). The virtual instruments developed by LabVIEW, compared to traditional instruments, have low development and maintenance costs, short technology refresh cycle, flexible and open system, and good compatibility, etc. Therefore, this technology is a new direction in the field of automatic testing and electronic measuring instruments<sup>[19]</sup>.

We select LABVIEW as the software development platform, use the remote control port of the Q8384 as spectrometer, develop the FBG sensing remote testing software, and realize the FBG reflection wavelength data acquisition and analysis by spectrometer. Using event structure design in LABVIEW, the system designs 10 subprograms as the response to the front panel event: default parameter settings, scanning parameters setting, single scan, progressive scan, data fitting, waveform storage and playback, temperature and strain measurement, stopping progressive scan and exiting the program. When the spectrometer is detecting, the parameters including basic parameters for the default parameter settings and scan settings are set. Default parameter setting is used for the initialization of spectrometer, i. e. reading/writing data formats, data acquisition points. Scanning basic parameters setting is mainly used for the center wavelength, measuring range, reference peace and

horizontal scale setting. The flowchart of the whole program design has been shown in Fig. 2.

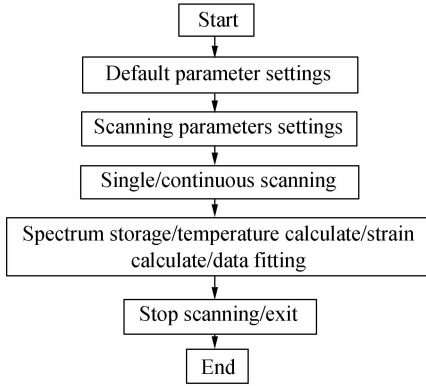

Fig. 2 Flowchart of the system program design

## 2.1 Automatic scanning realization

The MEA1, OSD1 and OSD0 are program data of

LabVIEW. Using the command MEA1 can control a single scan of spectrometer, command OSD1 can read the horizontal wavelength in the scanning information, command OSD0 can read the energy level information of vertical axis, command OPK can read the wave peak information in the scanning. During the designing, the command MEA1, OSD1, OSD0 and OPK form a one-dimensional array of string format (data command collection), then index commands by “For loop”, and call the driver to write the commands to spectrometer after the index. On the basis of a single test program, the “While loop” is added, at the same time, the time interval is controlled in continuous scanning spectrometer by adding delay. This can implement the spectrometer remote automatic continuous scanning, and the program structure is shown in Fig. 3.

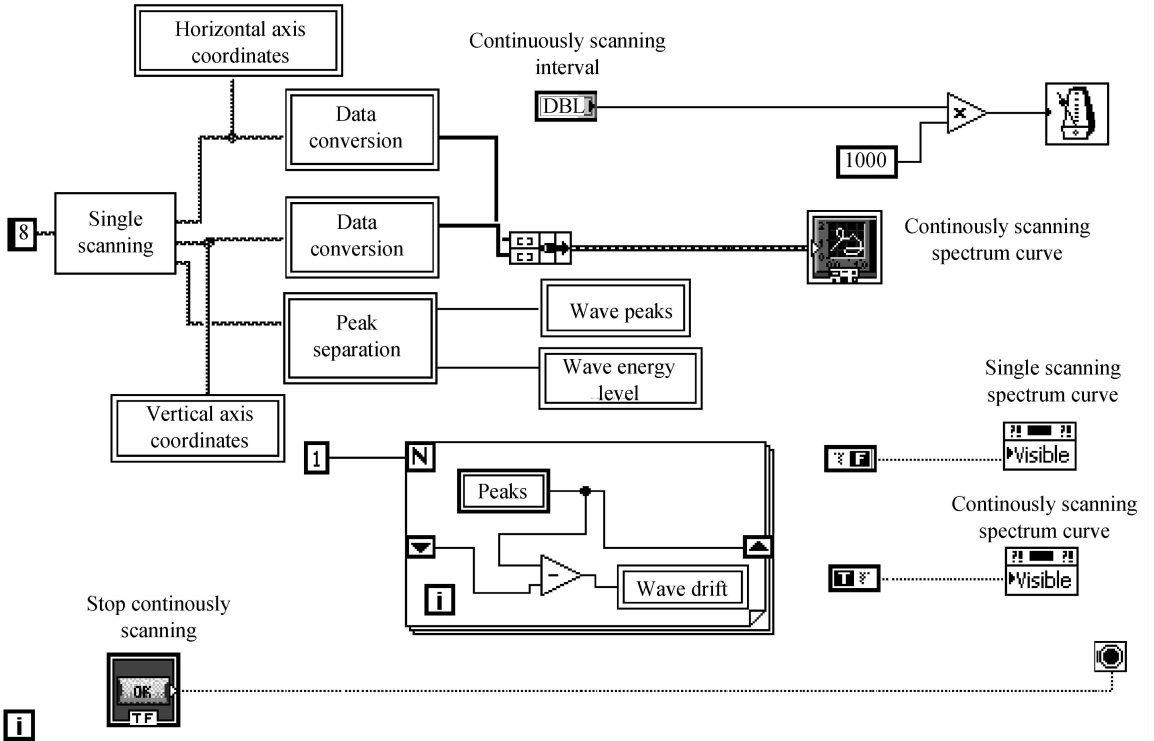

Fig. 3 Program structure of progressive scan panel

## 2.2 Data save and read

The collected data is saved as a text file (\*.txt) which is stored on the computer's hard disk. When the “Save data” button is pressed, it will pop up data read path. Enter the file read path and name, then click “OK”, the graphics will be displayed in a single scan. During the data saving process, the horizontal axis and vertical axis will be converted to the array of data, and saved as \*.txt file by “Write to spreadsheet file VI”. In the data reading process, through the “Current VIs path” obtain the current and the read path, and then send it to “Build path VI” and makes up the file path, it is easy to use by “Read from spreadsheet file VI”. The data read from the “Index array” can index out of

wavelength and energy level, for the subsequent analysis.

## 2.3 Realization of temperature and strain measurements

According to the effects of strain and temperature changes on FBG wavelength, Eq. (2) is changed as

$$\begin{cases} \Delta\lambda_B = K_\epsilon \epsilon \\ \Delta\lambda_B = K_T \Delta T \end{cases} \quad (3)$$

where,  $K_\epsilon = \lambda_B (1 - P_e)$ , which is the axial strain sensitivity coefficient;  $K_T = (\zeta + \alpha) \lambda_B$ , which is the sensitivity coefficient for temperature sensing. Scan the peakvalue by spectrometer and the wavelength difference before the experimental calibration, then enter the results to the calculation program. According to the coefficients of temperature and strain sensitivity

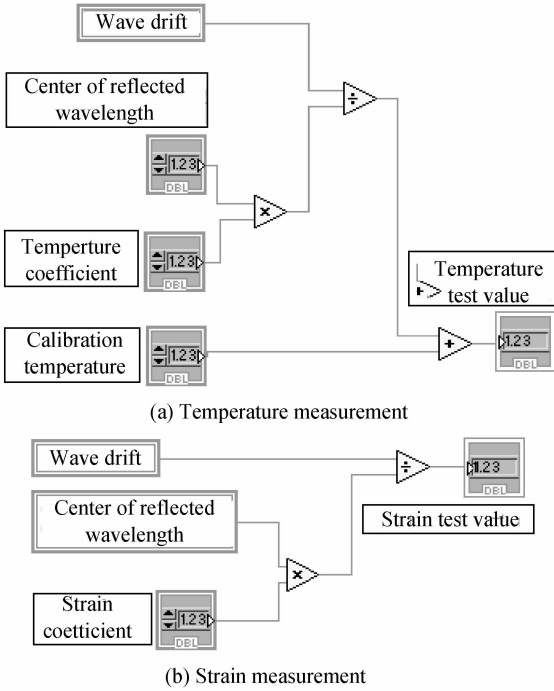

Fig. 4 Temperature and strain measurement principle of FBG sensors, the variable of temperature and strain

change can be evaluated. The principle of the system temperature and strain measurement has been given in Fig. 4.

2.4 Realization of data fitting

In the practical experiments, the statistical law of the actual measurement data should be analyzed, which can facilitate the linear rule analysis of the designed FBG sensors, so the system designs a subprogram for the analysis of these test data. Program design uses an embedded event in a “While loop” structure. When selecting “True”, the experimental data enters the “While loop” through the shift registers, then connects the corresponding port of “Linear fitting” for processing by the array index data, the obtained results of fitting curves in “XY graph”, the fitted curve equation from an event in a “For loop” structure calculation, and the calculated parameters using the least squares estimates. When pressing the “Data analysis function”, the appropriate data is entered in the pop-up panel and it will get the fitting curves and formulas. The data fitting program is shown in Fig. 5.

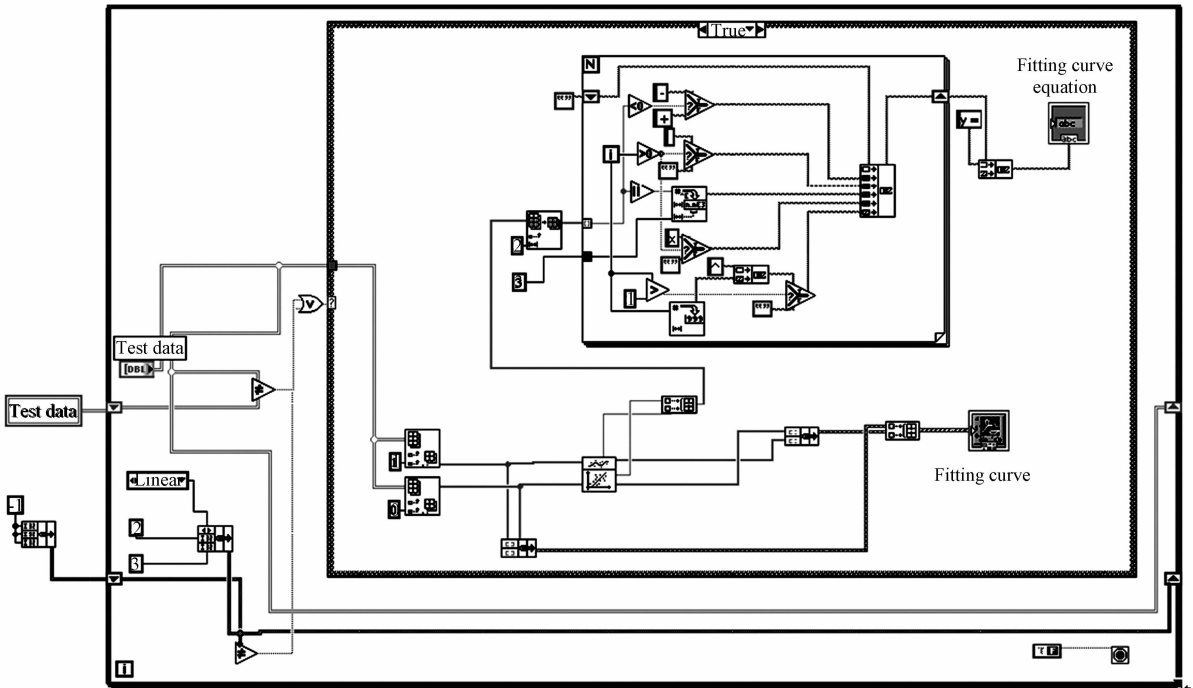

Fig. 5 Program structure of the data and functionality

2.5 Remote testing interface

According to the requirements of the FBG sensing remote test system and the individual modules feature, the designed software interfaces of FBG sensing remote test system are shown in Fig. 6. Their main functions include the scanning parameters setting up, reflection spectrum display, peak display, spectrogram storage, test data processing and real-time display for temperature and strain.

The system can meet the needs of FBG remote sensing automatic measurement. The testing process is fast and simple, which can significantly reduce the staff of complex operations for the general test, the test results can be electronically stored, which is easy to manage spectral characteristics of the device data. The use of staff is avoided to operate the spectrometer directly, which can extend the service life of the spectrometer.

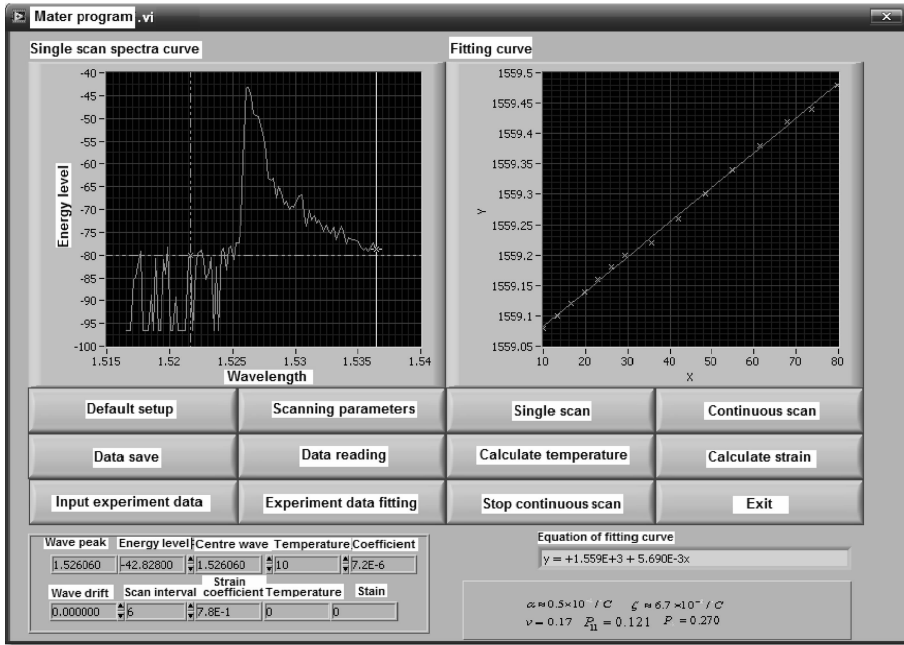

Fig. 6 The software interfaces of FBG sensing remote test system

### 3 Experiment and data analysis

In order to test functions of the automatic remote FBG measuring system based on LabVIEW, FBG strain testing of metal structures is targeted on experimental study. In the application of FBG strain testing of metal structures, one of the most important technical difficulties is the compatibility issue between the FBG sensor and the measured structure. It is simple to directly bond the FBG on the surface of the metal components using adhesive, but the nonlinear creep, aging and other issues of the adhesive could lead to the adhesive being not strong, and the FBG sensors are easy to fall off from the metal component.

#### 3.1 Experimental principle and plan

Strain is one of the most important parameters to reflect the characters of materials and structural mechanics. It can get the strength reserve information from the strain distribution of materials and structure, and determine the locations of stress concentration and the actual loading conditions. Strain measurement has been used in many fields, and the following experiment is using the FBG sensor to test the strain of steel beam based on the LabVIEW automatic testing platform.

Considering the matching problem of FBG sensor and the measured deformation of the structure, the materials and nature of the matrix of sensor and structure under test are as similar as possible. Therefore, using adhesives mixed with metal powder method in grooves of pure bending beam with packaged FBG. This method is similar to the Metal Powder Injection Molding (MIM) in plastic injection molding industry. In the experiment, the aim of using MIM

technique is to reduce the strength of the impact of metal components with the groove, and maximum protection of the FBG sensor. The main considerations of the metal powder are the shape, size and particle size composition, etc. Selecting the smaller size powder can make metal powder and adhesive fully integrated, and it can keep the powder with high relative friction. In the experiment, nickel powder is selected as the adhesives mixed media, it is mainly considered that the metal nickel has good mechanical strength and ductility, high temperature resistance of refractory and high chemical stability, and can be not in the air oxidation, etc.

Adhesive is the flow carrier of the metal powder, and the connection media of the powder particles to maintain a specific shape, this requires that the adhesive has good mobility. In the experiment, the epoxy DG-3Sas adhesive is selected, which is a modification epoxy adhesive and has resistant of low temperature ( $-60 \sim 150$  °C) curing. The beam material chosen in the experiment is the Q235 mild steel with sizes of  $650 \text{ mm} \times 40 \text{ mm} \times 20 \text{ mm}$ . We cut a V-groove on one side of the steel beam surface, then polish it with sandpaper and make it clean.

This single mode fiber product A1559.0 is selected as the FBG sensor, its center wavelength is 1559.0 nm, the reflectivity is greater than 90%, and the band width is less than 0.3 nm. The stripping fiber length of the FBG is 16 mm, and the length of grating area is 8 mm. After processing of the FBG surface, place the FBG at the center of V-groove to ensure that the measurement of FBG strain is the center of the steel beam. Firstly, the two ends of FBG optical fiber parts

are fixed in the V-groove, then the DG-3S is mixed with nickel powder, which ensures that the adhesive curing strength increases and the mixed-adhesive is viscous appropriate to package the FBG. In the process of filling the adhesive, the horizontal is kept fill in one direction, which can prevent the gas from being mixed into the adhesive and ensure uniformity of adhesive. When filling is completed, the surface of the package is processed with steel ruler to ensure the V-groove smooth surface, and then it is placed indoor 48 h to complete cured. Fig. 7 gives the picture of pure bending beam after completing cured and its dimensional drawing.

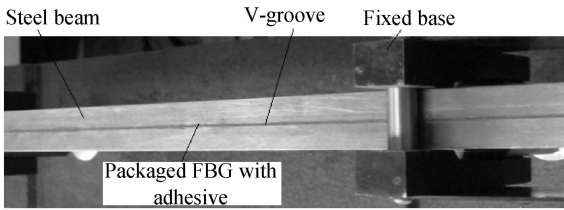

(a) Pure bending beam after completing cured

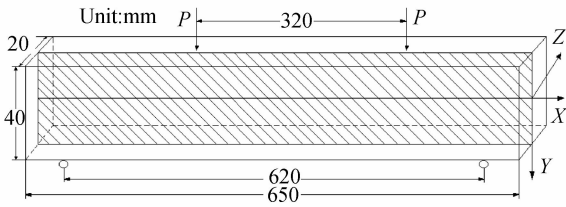

(b) Dimensional drawing of the pure bending beam

Fig. 7 Picture of beam after completing cured and its dimensions

The experimental devices include the Q8384 spectrometer, ASE broadband source, couplers, computer and BWQ-1 pure bending beam experimental platform. After the fixed FBG in the pure bending beam being cured, the installation FBG side of the beam tension test has been experimented, the picture of the whole system is shown in Fig. 8.

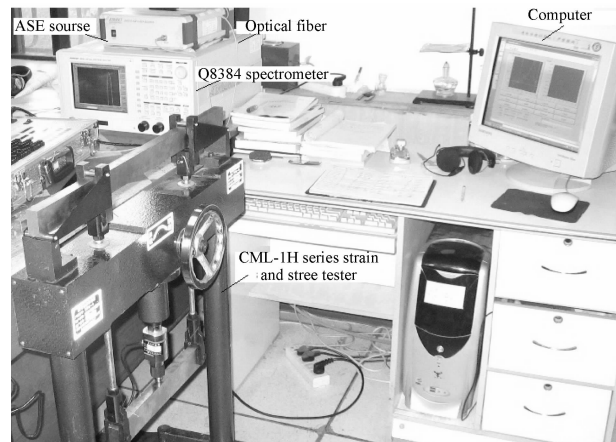

Fig. 8 Physical picture of the entire system

### 3.2 Experimental data and analysis

As shown in Fig. 8, during the testing process,

the practical imposed force is measured and monitored by CML-1H series of strain and stress tester, the applied force is detected and transferred to the FBG sensor, the measured data is shown in the output LED display.

In the tensile strain measurement, the side of beam with V-groove should be in down, making the FBG in a state of tension. Q8384 spectrometer is used to measure the center wavelength changes of FBG, its resolution is 10 pm, and measurement accuracy is 20 pm. The FBG center reflect wavelength with both the load and unload changes are test. According to the remote automatic testing platform based on LabVIEW aforementioned, the test results are analyzed. The fitting curves of the FBG wavelength change with the beam strain under the load and unload tensile strain have been given in Fig. 9 (a) and (b).

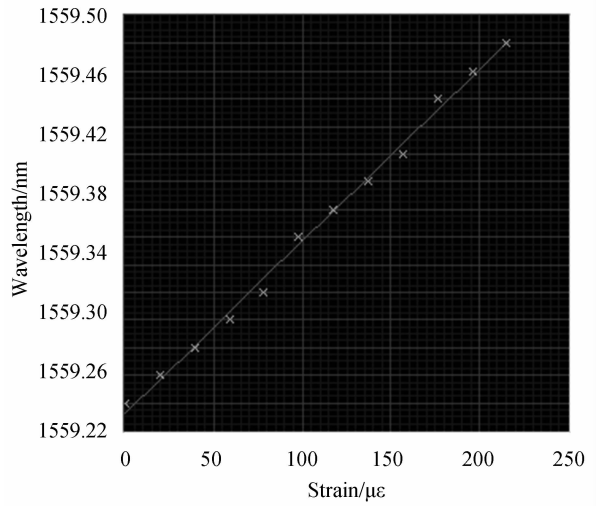

(a) Fitting curve under load state

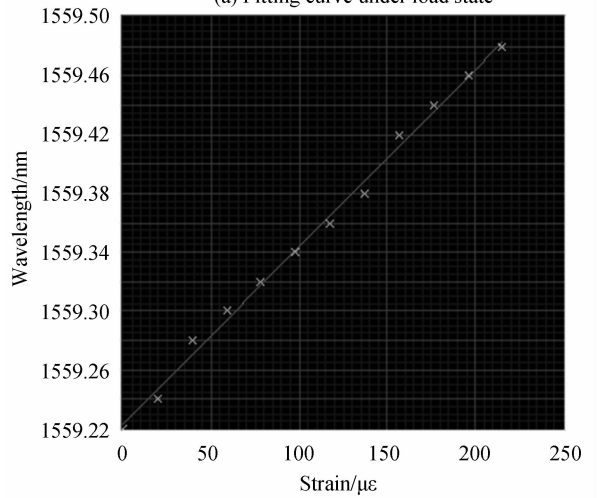

(b) Fitting curve under unload state

Fig. 9 Fitting curves of the FBG wavelength with strain changes based on the LabVIEW test platform

From the test results, it can be found that the FBG center wavelength changes from 1 559. 220 nm to 1 559. 480 nm. However, the load force is changed to

3300 N, and the value of strain change of the steel beam  $\Delta\epsilon$  is calculated as 215.458  $\mu\epsilon$  by

$$\Delta\epsilon = F/15.316 \quad (4)$$

so the strain sensitivity  $\Delta\lambda/\Delta\epsilon$  can be calculated as 1.2067 pm/ $\mu\epsilon$ . The test results show that the FBG automatic analysis test system based on LabVIEW can realize real-time monitoring and data analysis conveniently.

## 4 Conclusion

In this paper, the FBG sensor remote automatic test systems is developed by using LabVIEW graphical controls, realizing spectral reflectance graph displays, spectral peak storage, test data processing, and real-time display of temperature and strain. The strain/force integrated tester is used for tension test of a steel beam with embedded FBG packaged. The experiment data acquisition and analysis results based on the LabVIEW automatic testing platform is in line with the design expectations, and the system realizes the real-time monitoring and data storage capabilities. It is easy to manage spectral characteristics of the device data, and the staff directly operating is avoided, which can extend the service life of the spectrometer.

### References

- [1] QI H, IYENGAR S S, CHAKRABARTY K. Distributed sensor networks - a review of recent research[J]. *Journal of the Franklin Institute*, 2001, **338**(6): 655-668.
- [2] JING W C, WANG G H, LIU K, et al. Application of weighted wavelength algorithm on the demodulation of a fiber Bragg grating optical sensing system [J]. *Journal of Optoelectronics Laser*, 2007, **18**(9): 1022-1025.
- [3] LI Guo-wei; PEI Hua-fu; YIN Jian-hua. Monitoring and analysis of PHC pipe piles under hydraulic jacking using FBG sensing technology[J]. *Measurement*, 2014, **49**(3): 358-367.
- [4] GRATTAN K T, SUN T. Fiber optic sensor technology: an overview[J]. *Sensor and Actuators*, 2008, **82**(1-3): 40-61.
- [5] SENHAJI R K, MOHAMED N. Study of parametric sensitivity of the general model of transmission line [J]. *International Journal of Computer Science Issues*, 2012, **9** (55-2): 345-349.
- [6] FRAZAO O, ROMERO R, REGO G, et al. Sampled fiber Bragg grating sensors for simultaneous strain and temperature measurement[J]. *Electronics Letters*, 2002, **38**(5): 693-695.
- [7] JIMENEZ F J, FRUTOS J D. Virtual instrument for measurement, processing data, and visualization of vibration patterns of piezoelectric devices [J]. *Computer Standards & Interfaces*, 2005, **27**(7): 653-663.
- [8] WU Jun, CHEN Wei-min, SHU Yue-jie, et al. Embedded strain homogenized FBG sensor for smart cables [J]. *Acta Photonica Sinica*, 2015, **44**(7): 0706002.
- [9] SHU Yue-jie, CHEN Wei-min, ZHANG Peng, et al. Investigation on evaluation theory of fiber Bragg grating tensile fatigue property [J]. *Acta Photonica Sinica*, 2013, **42**(7): 805-811.
- [10] LIU Huan-lin. Concentration and temperature sensing accurately in a concatenated FBG and LPG[J]. *Optik*, 2015, **126**(6): 649-654.
- [11] SU Yang, WU Chuan-xin, ZHANG Bao-fu. Use of the stokes parameters of FBG for transverse strain sensing and the optimization of the grating structure[J]. *Frequenz*, 2014, **68**(1-2): 63-68.
- [12] PENG Hui, ZHOU Bi-hua, WANG Hui. A new method for resolving the influence of circular birefringence in FBG weak pressure sensor[J]. *Measurement*, 2014, **58**(12): 280-285.
- [13] SHEN Wei, YAN Ren-jun, XU Lin. Application study on FBG sensor applied to hull structural health monitoring[J]. *Optik*, 2015, **126**(17): 1499-1504.
- [14] SUN Li, SUN Qian-qian, REN Liang, ZHANG Xin-shou. A new method for underground pipeline corrosion monitoring applied FBG[J]. *Acta Photonica Sinica*, 2012, **41**(1): 6-10.
- [15] CAI Li, TAN Yue-gang, WEI Qin. Nonlinear vibration-FBG sensing technique for plate detection [J]. *Sensor Review*, 2015, **35**(3): 287-295.
- [16] ZHU Xiang, YANG Yuan-hong. Spectrum of dual-wavelength phase shift FBG and its application in fiber sensing[J]. *Acta Photonica Sinica*, 2014, **43**(9): 0906007.
- [17] QI Jian. A comparison study of the sensing characteristics of FBG and TFBG[J]. *Sensor Review*, 2013, **33**(1): 68-79.
- [18] SONG Da-wei, CHAI Quan, LIU Yan-lei. A simultaneous strain and temperature sensing module based on FBG-in-SMS [J]. *Measurement Science & Technology*, 2014, **25**(5): 055205.
- [19] ZHANG L, WANG J Y, SUI Q M. Application of LabVIEW on fiber Bragg grating demodulation system[J]. *Information Technology*, 2007, **6**(2): 36-39.