



混凝土结构设计原理

第6章 钢筋混凝土受扭构件承载力计算

成都理工大学环境与土木工程学院

建筑工程教研室范涛



第6章 钢筋混凝土受扭构件承载力计算

- 6.1 概述
- 6.2 受扭构件的试验研究
- 6.3 建筑工程中受扭构件承载力计算
- 6.4 公路桥涵工程中受扭构件承载力计算
- 6.5 小结

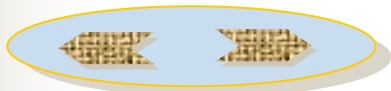



§ 6.1 概述

6.1.1 土木工程中常见的受扭构件

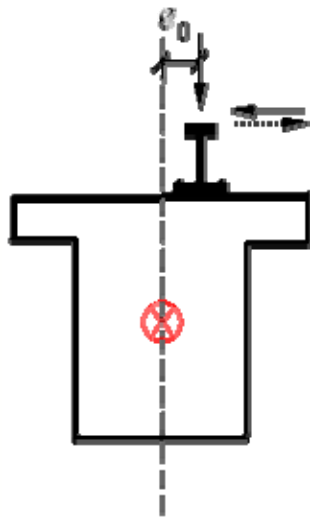
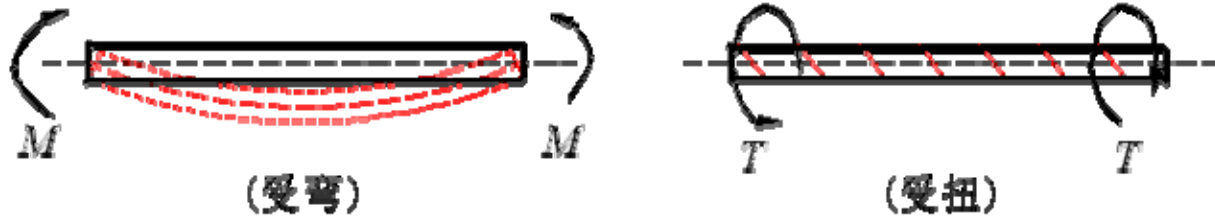

吊车梁

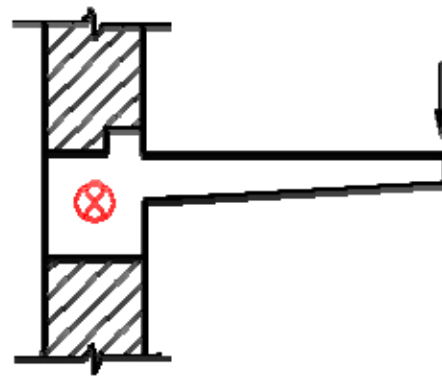

雨篷梁



天沟梁

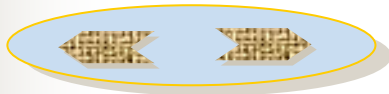



6.1.1 土木工程中常见的受扭构件

- 折线梁、曲线梁、框架边梁
- 有吊车的厂房柱
- 地震荷载作用下的角柱



曲梁

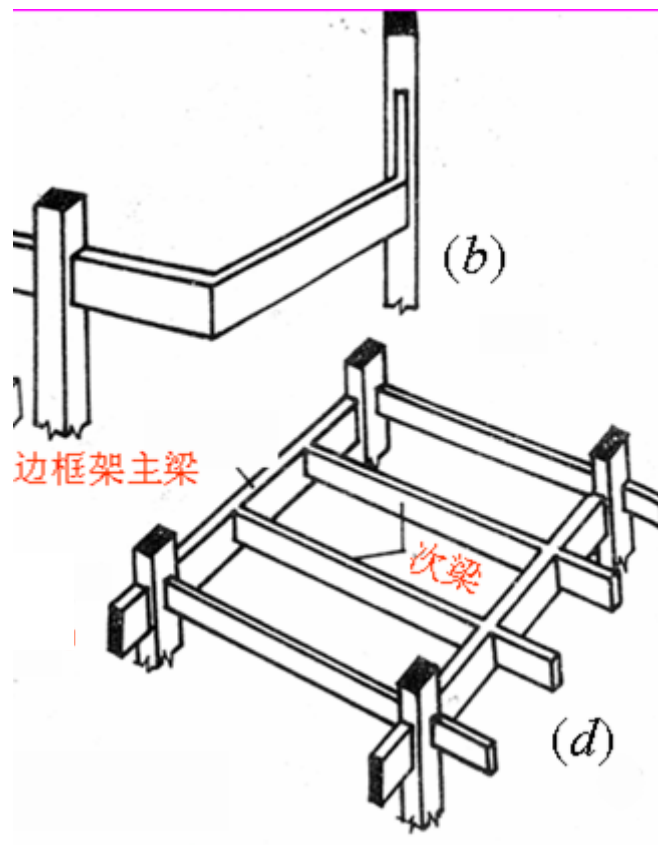

土木工程受扭构件的特点：
一般均为弯、剪、扭构件。



6.1.2 扭转的类型

1. 平衡扭转

扭转由荷载引起，内扭矩为平衡外扭矩所必需，如吊车梁、雨篷梁等。

◆ 扭矩可以根据平衡条件求得，与构件的抗扭刚度无关。
——静定问题。

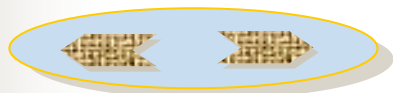
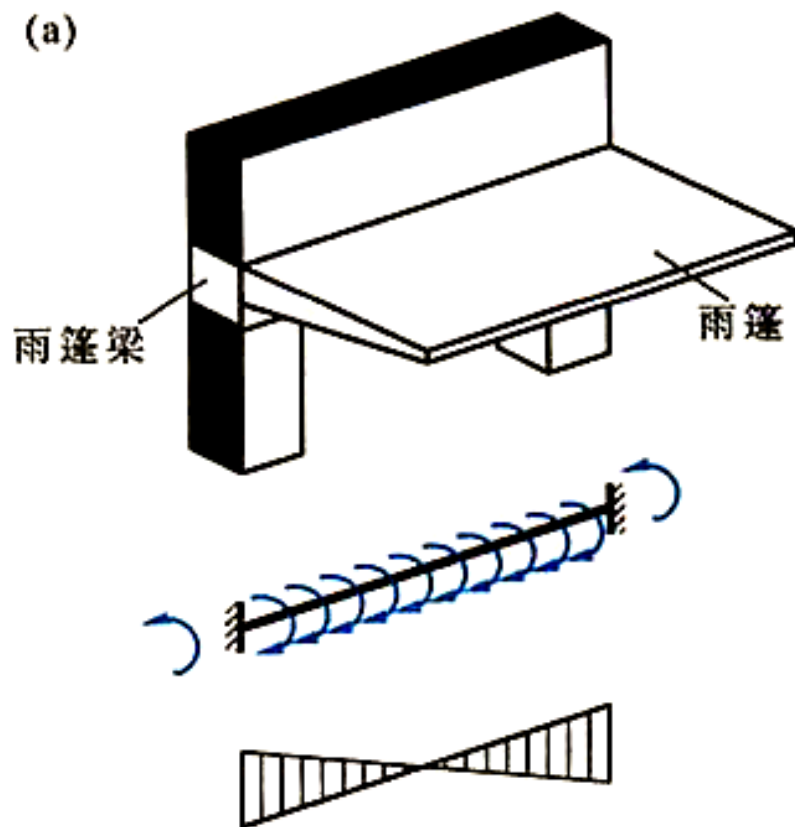



2. 协调扭转或附加扭转（约束扭转）

扭转由变形引起，并由变形连续条件所决定。如与次梁相连的边框架的主梁扭转。

◆ 扭矩是由相邻构件的变形受到约束而产生的，扭矩大小与受扭构件的抗扭刚度有关。

——超静定问题。

(b)

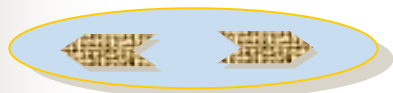
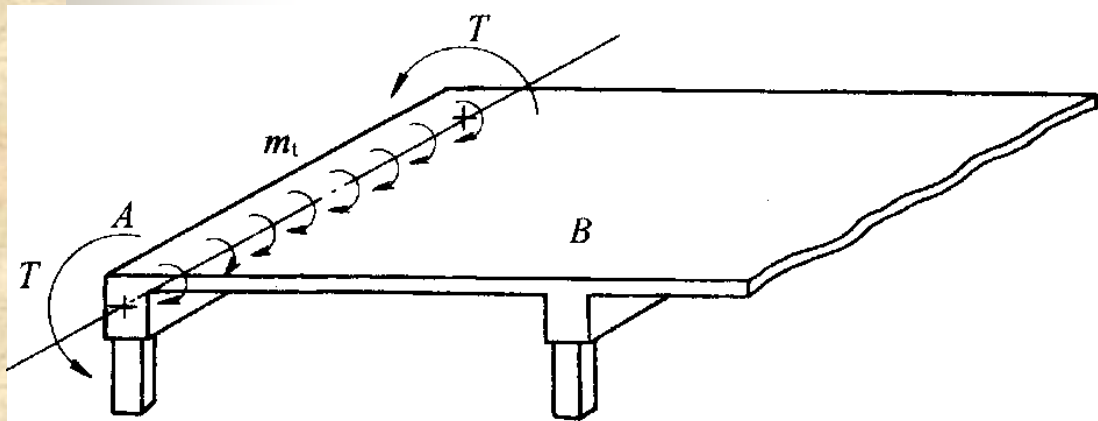
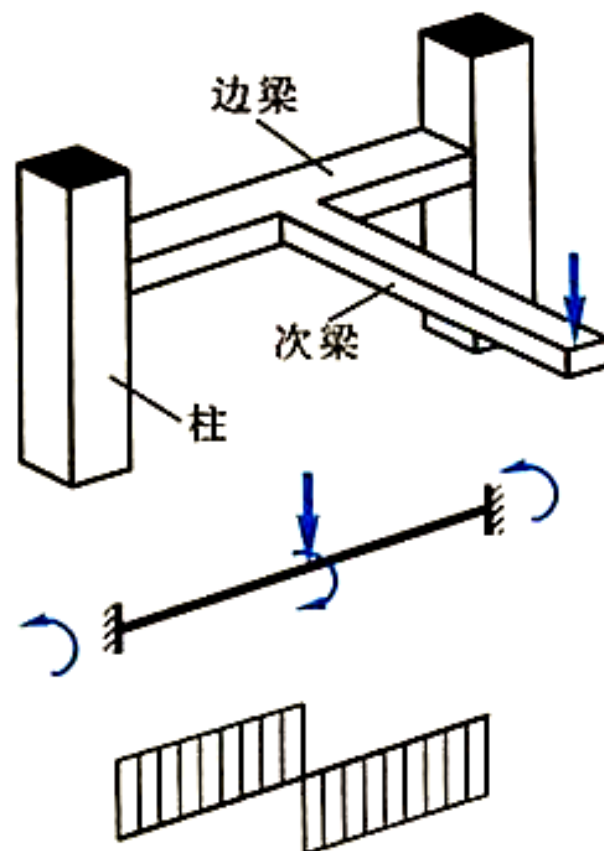



协调扭转的设计方法:

- 1. 《规范》规定的方法：即对支承梁(框架边梁)按弹性分析所得的两端扭矩设计值，经调幅后，再按弯剪扭构件进行配筋设计。根据国内的试验研究：
 - 当框架梁、柱为现浇，而梁上的板为预制时，对扭矩调幅系数的取值，不宜大于0.4(即经调幅后的扭矩设计值不宜小于0.6倍的弹性扭矩设计值)。
 - 当框架的板、梁、柱均为现浇时，由于结构的整体刚度较好，对扭矩调幅系数的取值，可适当放松。

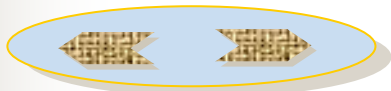



协调扭转的设计方法:

- 1. 《规范》规定的方法
- 2. 零刚度法: 是根据研究分析和参考国外现行规范有关条文内容, 所提出的较简便设计方法, 即**假定支承梁(框架边梁)的扭转刚度为零**(亦即取边梁两端的设计扭矩为零), **在边梁内仅需配置抗扭所需的构造钢筋**, 以满足边梁的延性和限制斜裂缝宽度的要求。

本章主要讨论**平衡扭转**计算。

协调扭转可用构造钢筋或内力重分布方法处理。

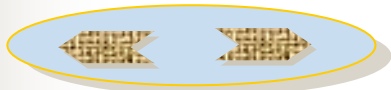



6.1.3 抗扭钢筋的形式

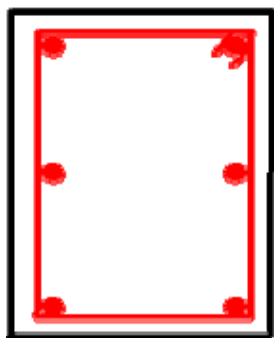

- 抗弯 —— 纵向钢筋；
- 抗剪 —— 箍筋或箍筋+弯筋；
- 抗扭 —— 箍筋+沿截面周边均匀布置的纵筋，且箍筋与纵筋的比例要适当。

6.1.4 受扭构件分类

纯扭 }
 剪扭 } 土木工程中少见；
 弯扭 }
 弯剪扭：土木工程中常见。

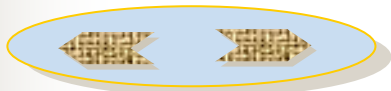



第6章 钢筋混凝土受扭构件承载力计算

- 6.1 概述
- 6.2 受扭构件的试验研究
- 6.3 建筑工程中受扭构件承载力计算
- 6.4 公路桥涵工程中受扭构件承载力计算
- 6.5 小结

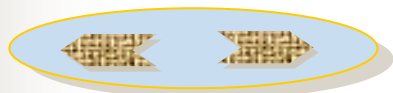

§ 6.2 受扭构件试验研究

1. 素混凝土纯扭构件

素混凝土纯扭构件



先在某长边中点开裂



形成一螺旋形裂缝，一裂即坏



三边受拉，一边受压

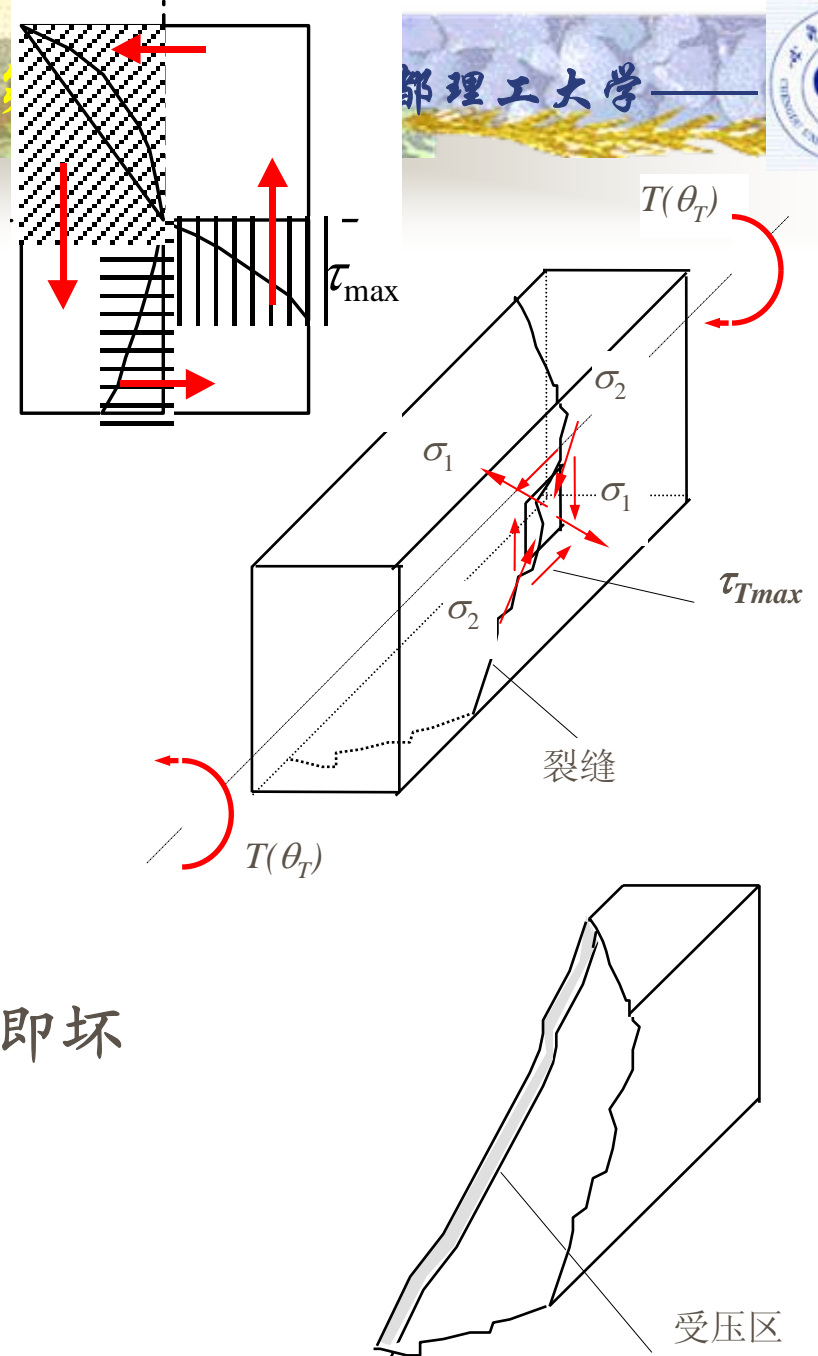

2. 钢筋混凝土纯扭构件

钢筋混凝土纯扭构件



开裂前钢筋中的应力很小



开裂后不立即破坏，裂缝可以不断增加，随着钢筋用量的不同，**有不同的破坏形态**

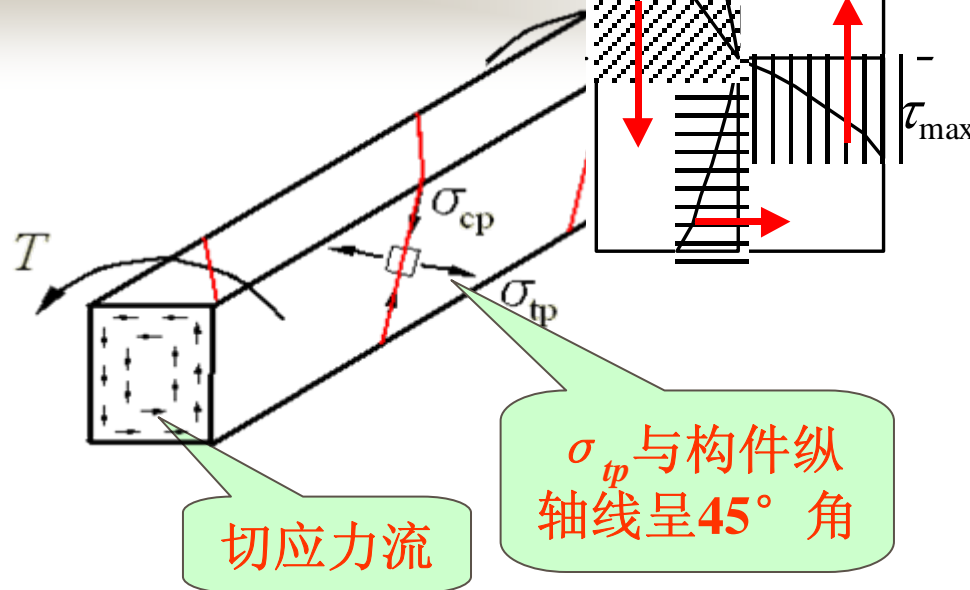

截面长边中点处切应力值为最大。

$$\sigma_{tp} = -\sigma_{cp} = \tau_{max}$$

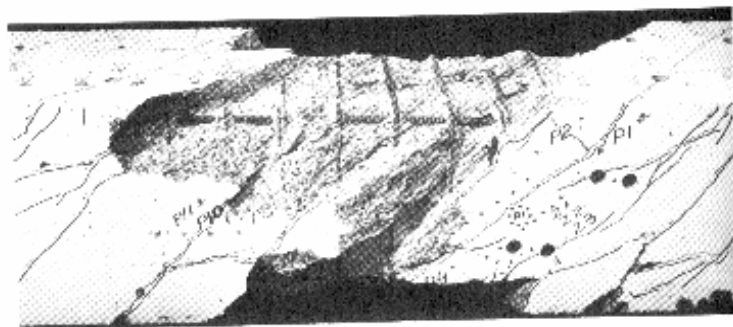



1. 钢筋混凝土纯扭构件

破坏形态

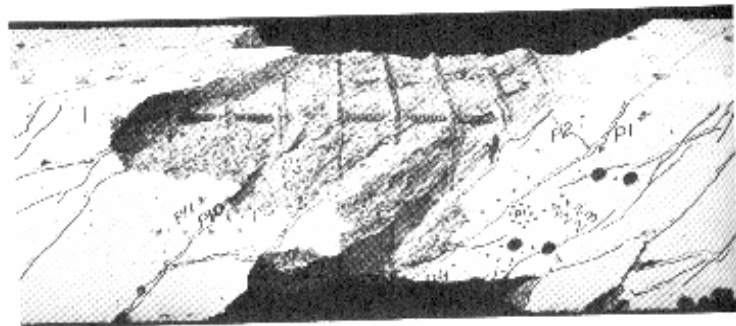

少筋破坏:

裂后钢筋应力激增，构件破坏

适筋破坏:

裂后钢筋应力增加，继续开裂，钢筋屈服，混凝土压碎，构件破坏

超筋破坏:

裂后钢筋应力增加，继续开裂，混凝土压碎，构件破坏，钢筋未屈服

部分超筋破坏:

裂后钢筋应力增加，继续开裂，混凝土压碎，构件破坏，纵筋或箍筋未屈服

设计时应避免出现

钢筋不能提高开裂扭矩，但能提高受扭构件的极限扭矩值



第6章 钢筋混凝土受扭构件承载力计算

- 6.1 概述
- 6.2 受扭构件的试验研究
- 6.3 建筑工程中受扭构件承载力计算
- 6.4 公路桥涵工程中受扭构件承载力计算
- 6.5 小结

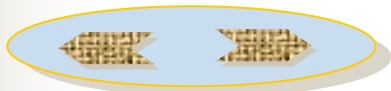



§ 6.3 建筑工程中受扭构件承载力计算

- 6.3.1 纯扭构件承载力计算
- 6.3.2 弯剪扭构件承载力计算
- 6.3.3 压弯剪扭构件承载力计算
- 6.3.4 受扭构件计算公式的适用条件及构造要求

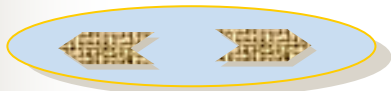
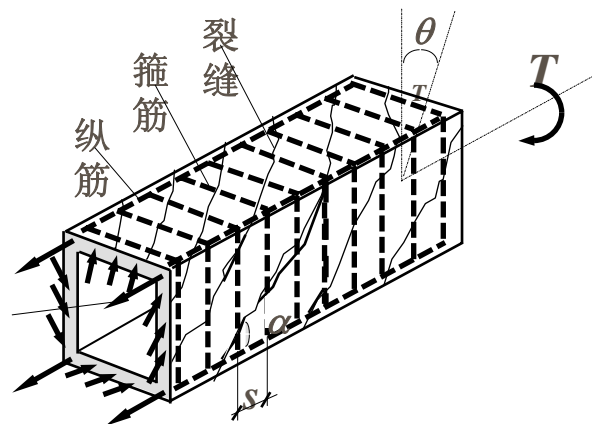



1. 矩形截面钢筋混凝土纯扭构件

(1) 开裂扭矩

➤ 理想弹性材料

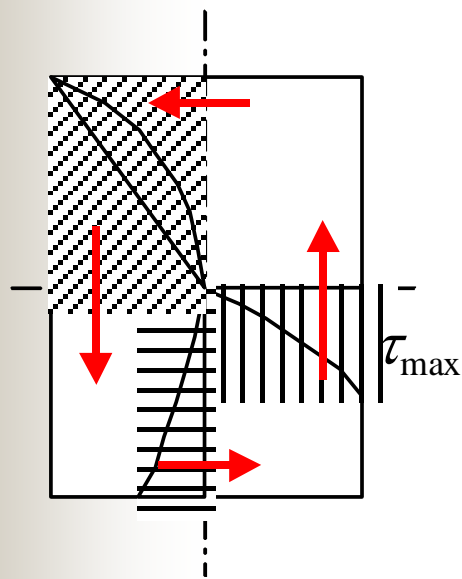
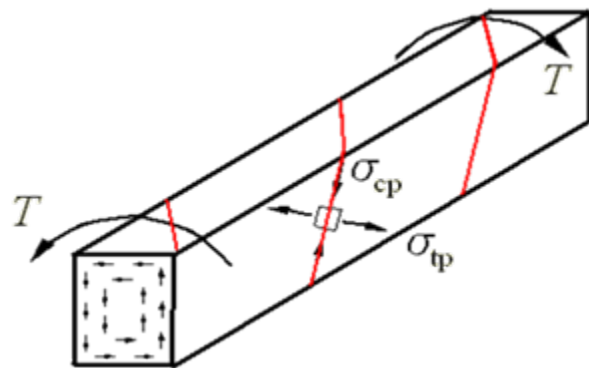

$$\tau_{\max} = \frac{T}{W_{te}}$$

$h/b=1\sim 10$
 $\beta=0.208\sim 0.313$

$$T_{cr,e} = f_t W_{te} = f_t \beta b^2 h$$

$$W_{te} = \beta b^2 h \text{ —— 截面受扭弹性抵抗矩}$$

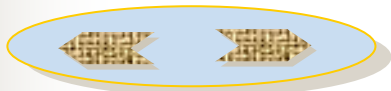



(1) 开裂扭矩

➤ 理想弹塑性材料

➤ 切应力全截面达到混凝土抗拉强度时，结构达到混凝土上即将出现裂缝极限状态。

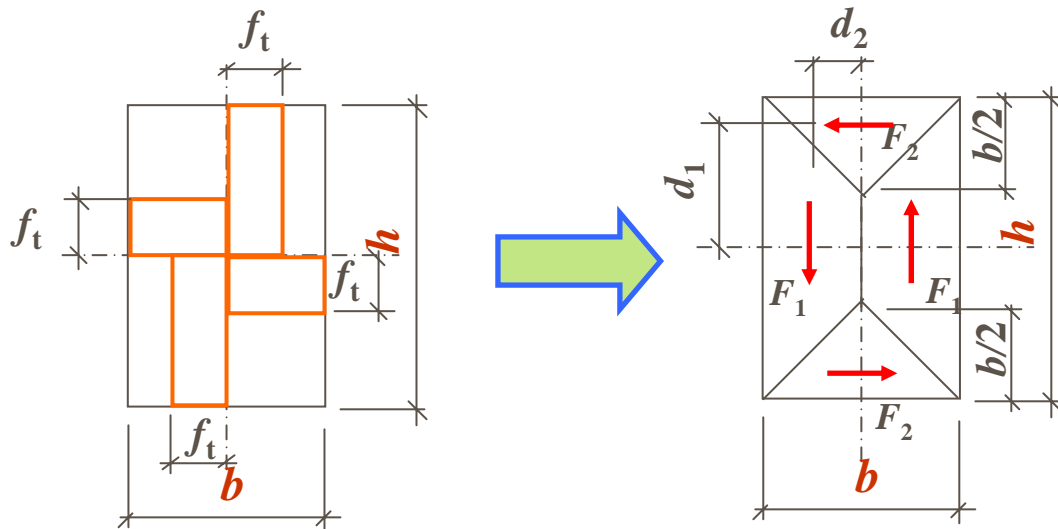

$$T_{cr,p} = 2(F_1 d_1 + F_2 d_2) = \frac{b^2}{6} (3h - b) f_t = W_t f_t$$

$$W_t = \frac{b^2}{6} (3h - b)$$

W_t —— 截面受扭塑性抵抗矩。

h 为截面长边边长； b 为截面短边边长。

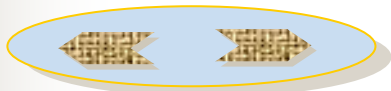



(1) 开裂扭矩

$$T_{cr} = 2(F_1 d_1 + F_2 d_2) = \frac{b^2}{6} (3h - b) f_t = W_t f_t$$

混凝土材料并非理想
弹塑性材料，故可取



$$T_{cr} = 0.7 W_t f_t$$

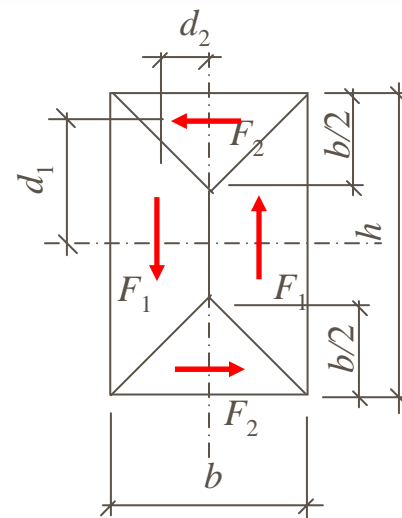

理想弹塑性材料

- 素混凝土纯扭构件

$$T = 0.7 f_t W_t$$



(2) 矩形截面钢筋混凝土纯扭构件承载力计算

1. 基本假定

*箱形截面：忽略核心区混凝土的作用

*变角空间桁架

*混凝土开裂后不承受拉力

*忽略混凝土斜杆的抗剪作用

*忽略纵筋和箍筋的销栓作用

➤斜裂缝与杆件轴线的夹角 α 会随纵筋与箍筋的**强度比值 ξ** 而变化。

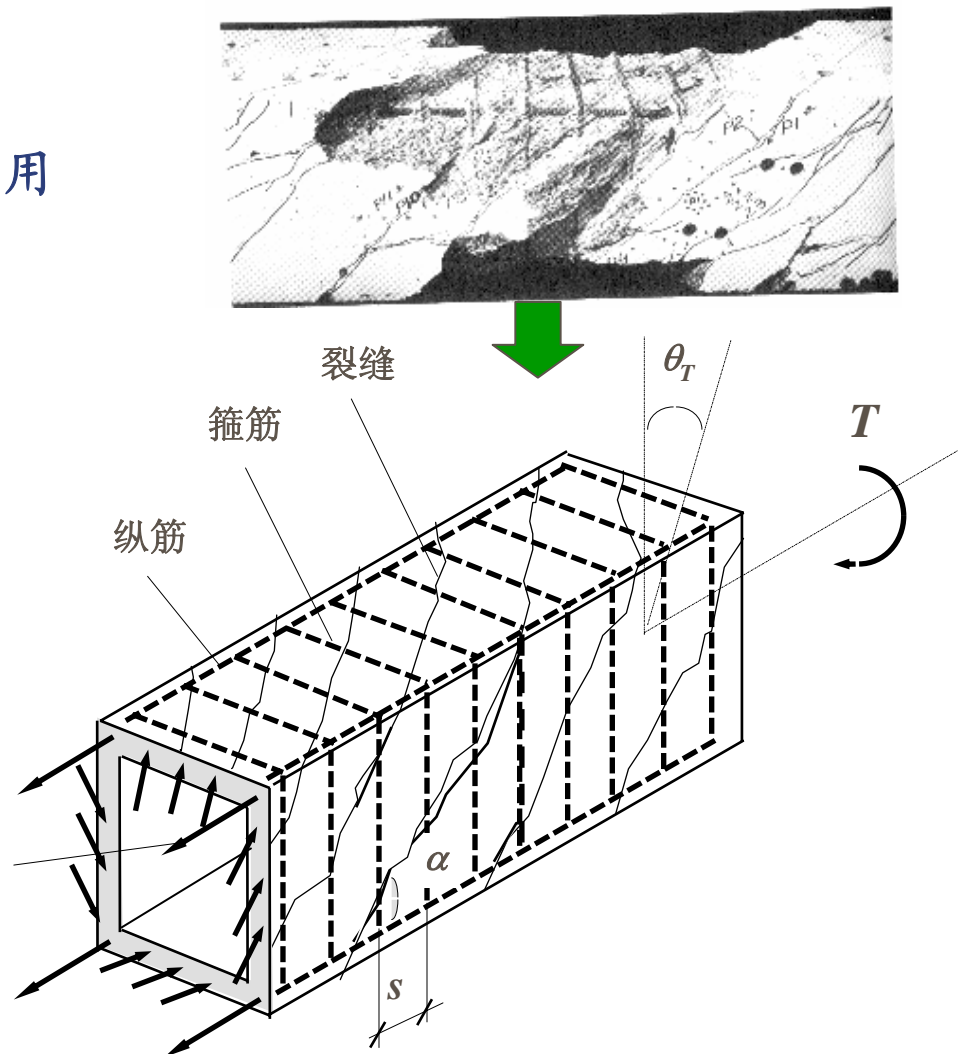



(2) 矩形截面钢筋混凝土纯扭构件承载力计算

$$\operatorname{ctg} \alpha = \sqrt{\frac{A_{stl} f_y s}{A_{svt1} f_{yv} \mu_{cor}}} = \sqrt{\zeta}$$

纵筋与箍筋
配筋强度比

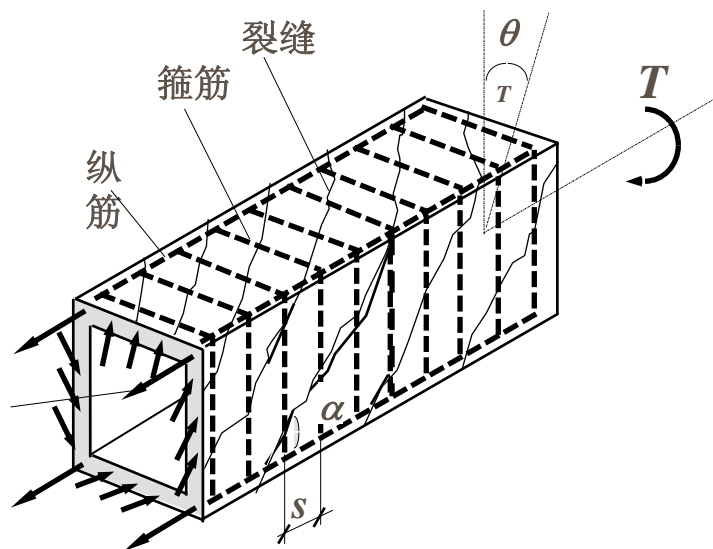

沿截面核心周长单位长度总筋的抗扭承载力:

$$\frac{A_{stl} f_y}{\mu_{cor}}$$

沿构件纵向单位长度单肢箍筋的抗扭承载力:

$$\frac{A_{svt1} f_{yv}}{s}$$

$$\zeta = \frac{\frac{A_{stl} f_y}{\mu_{cor}}}{\frac{A_{svt1} f_{yv}}{s}} = \frac{A_{stl} f_y s}{A_{svt1} f_{yv} \mu_{cor}}$$

$$u_{cor} = 2(b_{cor} + h_{cor})$$



(2) 矩形截面钢筋混凝土纯扭构件承载力计算

钢筋混凝土纯扭构件的抗扭承载力由混凝土的抗扭承载力 T_c 和箍筋与纵筋的抗扭承载力 T_s 两部分构成：

$$T_u = T_c + T_s$$

◆混凝土的抗扭承载力和箍筋与纵筋的抗扭承载力并非彼此完全独立的变量，而是相互关联的。

借用 $f_t W_t$ 作为基本变量。

选取箍筋的单肢配筋承载力 $f_{yv} A_{st1}/s$ 与截面核心部分面积 A_{cor} 的乘积作为基本变量再用 ζ 来反映纵筋与箍筋的共同工作。

$$T_u = \alpha_1 f_t W_t + \alpha_2 \sqrt{\zeta} \cdot \frac{f_{yv} A_{st1}}{s} \cdot A_{cor}$$



(2) 矩形截面钢筋混凝土纯扭构件承载力计算

$$T_u = \alpha_1 f_t W_t + \alpha_2 \sqrt{\zeta} \cdot \frac{f_{yv} A_{st1}}{s} \cdot A_{cor}$$



$$T = 0.35 f_t W_t + 1.2 \sqrt{\zeta} \frac{f_{yv} A_{st1} A_{cor}}{s}$$

$$0.6 < \zeta \leq 1.7$$

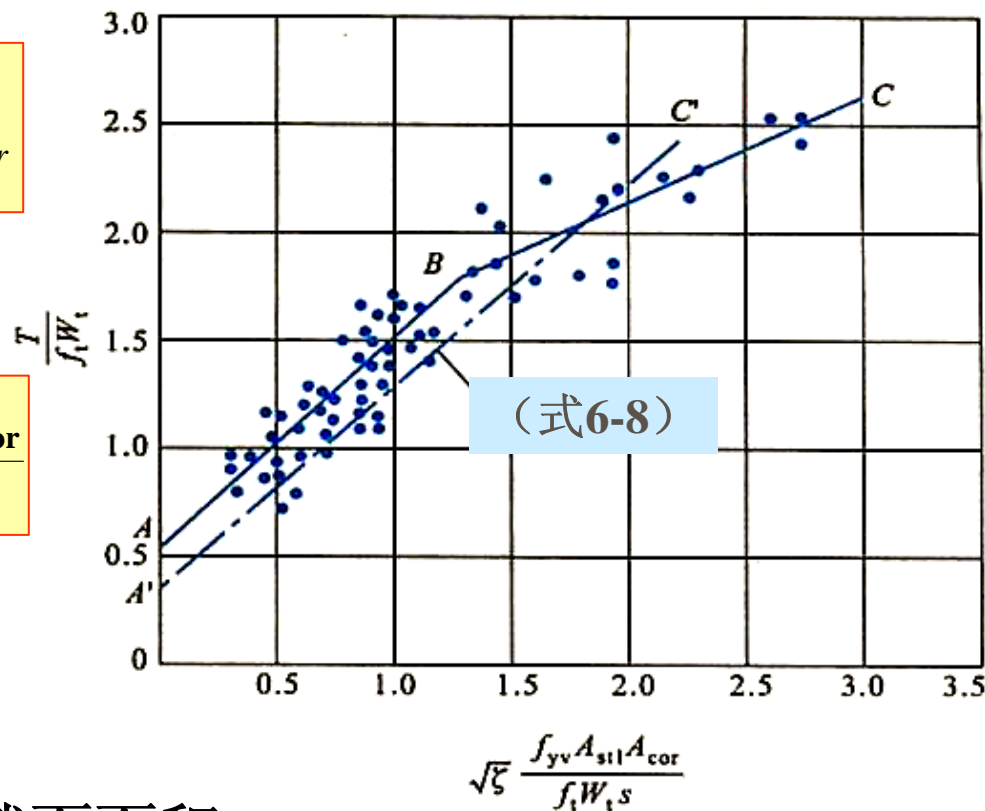

式中： s —— 箍筋间距；

A_{st1} —— 抗扭箍筋单肢截面面积；

A_{cor} —— 截面核心部分面积， $A_{cor} = b_{cor} \times h_{cor}$ ；

ζ —— 抗扭纵筋与抗扭箍筋的配筋强度比值；

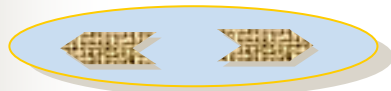



(2) 矩形截面钢筋混凝土纯扭构件承载力计算

$$T = 0.35f_tW_t + 1.2\sqrt{\zeta} \frac{f_{yv}A_{st1}A_{cor}}{s} \quad \dots 6-8$$

$$\zeta = \frac{f_y A_{st1} s}{f_{yv} A_{st1} u_{cor}} \quad \dots 6-9$$

$$0.6 < \zeta \leq 1.7$$

$$A_{cor} = b_{cor} \times h_{cor}$$

u_{cor} ——核芯部分的周长。

$$u_{cor} = 2(b_{cor} + h_{cor})$$

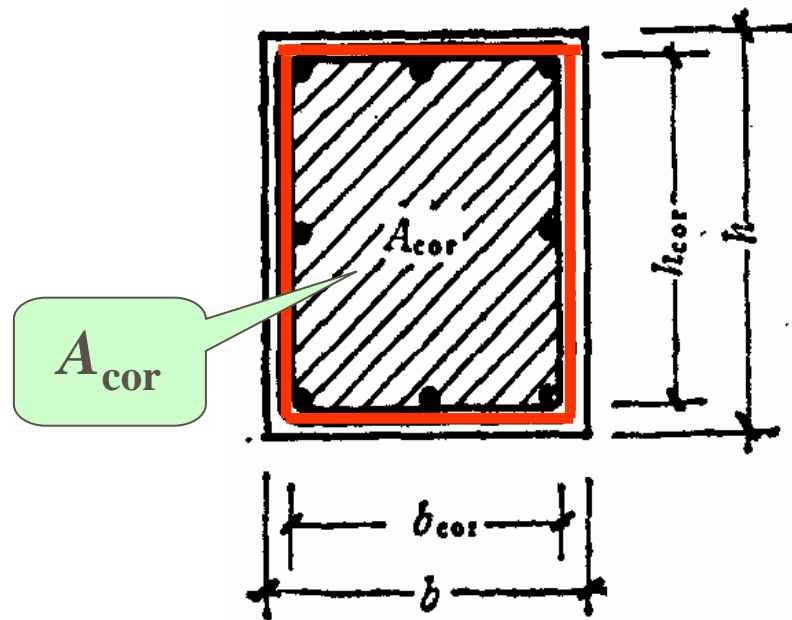

◆ 设计时，可先假定一个 ζ ($=1.0 \sim 1.3$) 值，然后由式 (6-8) 求 A_{st1} ，再由式 (6-9) 求 A_{st1} 。



2. T形和工字形截面钢筋混凝土纯扭构件

■ 试验分析

- 当T形截面腹板宽度大于翼缘厚度时，如果将其悬挑翼缘部分去掉，则可看出其腹板侧面斜裂缝与其顶面裂缝基本相连，形成断断续续相互贯通的螺旋形斜裂缝；即其斜裂缝是随较宽的腹板而单独形成，不受悬挑翼缘存在的影响。

◆ 对常用的T形及工字形截面划分数个矩形时，需以满足腹板的完整性为原则。

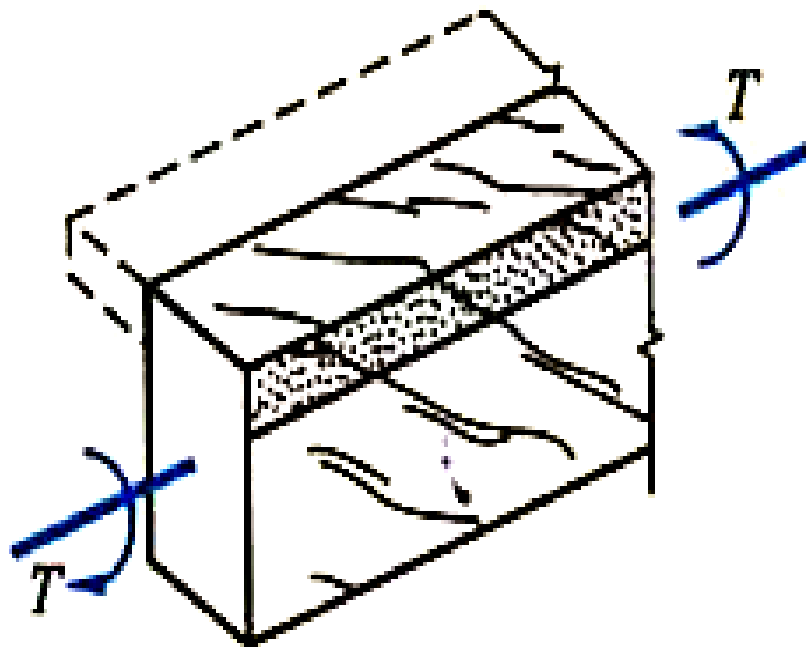



2. T形和工字形截面钢筋混凝土纯扭构件

■ 试验分析

- 对于配有封闭箍筋的翼缘，其截面抗扭承载力是随着翼缘的悬挑宽度的增加而提高。但当悬挑宽度过小，其提高效果不显著。反之，悬挑宽度过大，翼缘与腹板连接处整体刚度相对减弱，翼缘弯曲变形后易于断裂，不能承受扭矩作用。

封闭箍筋

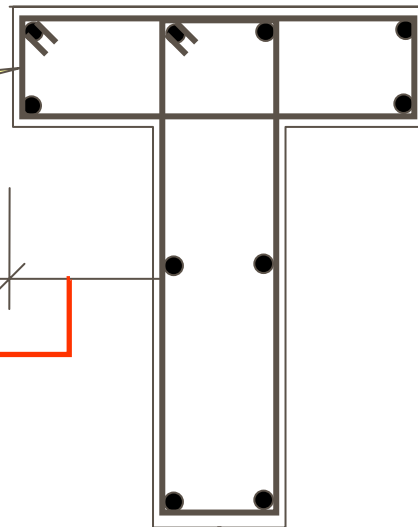

◆ 《规范》规定，取用悬挑宽度不得超过其厚度的3倍。



■ T形或工字形截面划分矩形块

- 《规范》为了简化起见，统一下图划分矩形块：

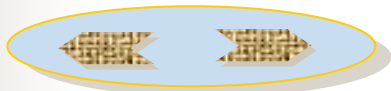
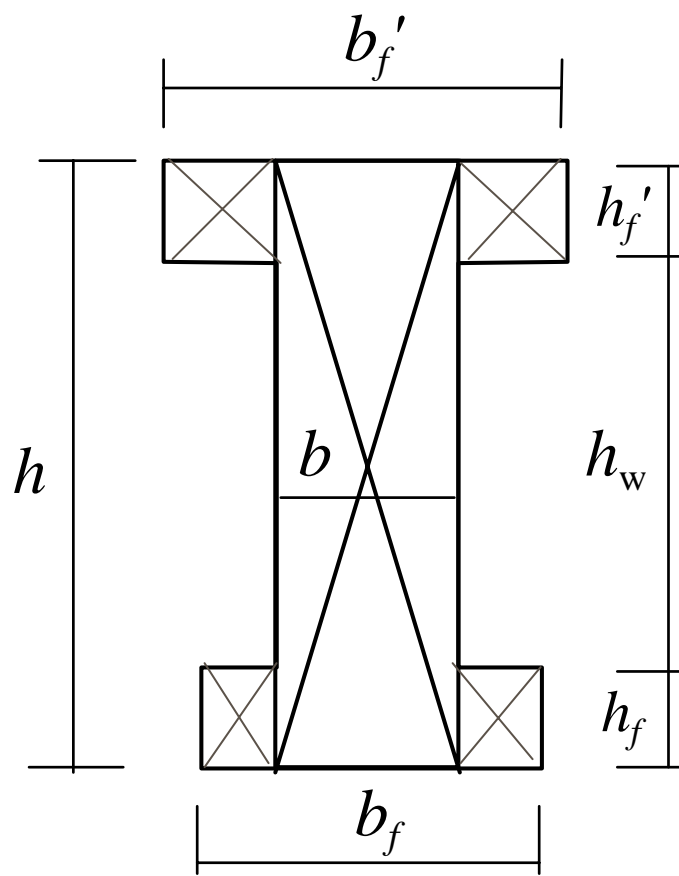
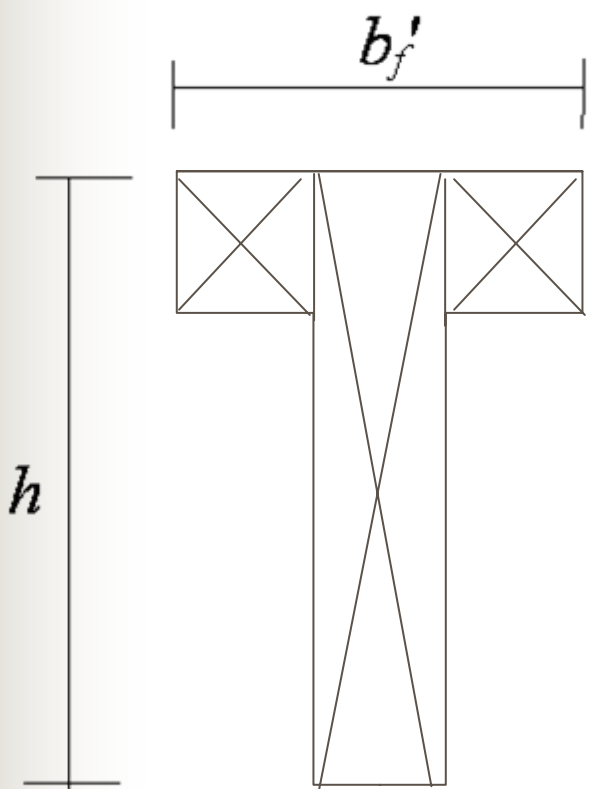



各个矩块的抗扭塑性抵抗矩:

■ 全截面

$$W_t = W_{tw} + W_{tf}' + W_{tf}$$

■ 腹板

$$W_{tw} = \frac{b^2}{6}(3h - b)$$

■ 受压翼缘

$$W_{tf}' = \frac{h_f'^2}{2}(b_f' - b)$$

■ 受拉翼缘

$$W_{tf} = \frac{h_f^2}{2}(b_f - b)$$

◆ 总的扭矩T按各矩形块的受扭塑性抵抗矩分配:



$$T_w = \frac{W_{tw}}{W_t} T$$

$$T_{f'} = \frac{W_{tf}'}{W_t} T$$

$$T_f = \frac{W_{tf}}{W_t} T$$



3. 箱形截面钢筋混凝土纯扭构件

$$T \leq 0.35\alpha_h f_t W_t + 1.2\sqrt{\zeta} f_{yv} \frac{A_{st1} A_{cor}}{S}$$

...6-16

α_h ——箱形截面壁厚系数;

$$\alpha_h = \frac{2.5t_w}{b_h} \quad \frac{2.5t_w}{b_h} > 1.0, \text{ 取 } \frac{2.5t_w}{b_h} = 1.0$$

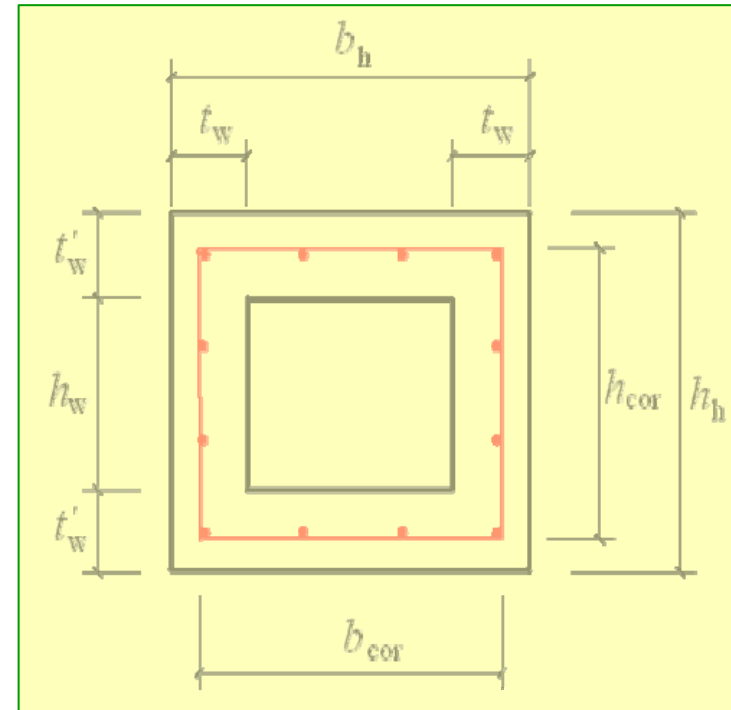

t_w ——箱形截面壁厚，其值不应小于 $b_h/7$;

$$W_t = \frac{b_h^2}{6} (3h_h - b_h) - \frac{(b_h - 2t_w)^2}{6} [3h_w - (b_h - 2t_w)]$$

$$\zeta = \frac{f_y A_{st1} S}{f_{yv} A_{st1} u_{cor}}$$

$$0.6 < \zeta \leq 1.7$$



补充例题：某矩形截面**纯扭构件**，承受扭矩设计值为 $T=18\text{kN}\cdot\text{m}$ ，截面尺寸 $250\text{mm}\times 500\text{mm}$ ，C25混凝土，箍筋为HRB335级钢筋，纵筋为HRB400级钢筋。环境类别为二类，试计算截面的配筋数量。

【解】 1、验算截面尺寸是否满足要求

$$W_t = \frac{b^2}{6}(3h - b) = \frac{250^2}{6} \times (3 \times 500 - 250) = 13.021 \times 10^6 \text{ mm}^3$$

$$\frac{T}{0.8W_t} = \frac{18 \times 10^6}{0.8 \times 13.021 \times 10^6} = 1.728 < 0.25\beta_c f_c = 0.25 \times 1.0 \times 11.9 = 2.975$$

故截面尺寸满足要求。



- 【解】
- 1、验算截面尺寸是否满足要求
 - 2、验算是否按计算配置抗扭钢筋

$$0.7 f_t W_t = 0.7 \times 1.27 \times 13.021 \times 10^6 = 11.58 \text{ KNN.m} < T = 18 \text{ KNN.m}$$

故需按计算配置受扭钢筋。

3、抗扭箍筋的计算

$$b_{cor} = 250 - 30 \times 2 = 190 \text{ mm} \quad h_{cor} = 500 - 30 \times 2 = 440 \text{ mm}$$

假定： $\zeta = 1.1$

$$\frac{A_{st1}}{s} = \frac{T - 0.35 f_t W_t}{1.2 \sqrt{\zeta} f_{yv} A_{cor}} = \frac{18 \times 10^6 - 0.35 \times 1.27 \times 13.021 \times 10^6}{1.2 \sqrt{1.1} \times 300 \times 190 \times 440} = 0.387$$

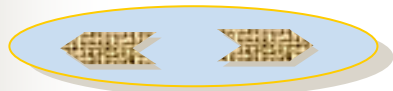



【解】

3、抗扭箍筋的计算

$$\frac{A_{st1}}{s} = 0.387$$

选用 $\Phi 8$ 箍筋 ($A_{sv1} = 50.3\text{mm}^2$), 双臂箍, $n = 2$

$$\text{则 } s = \frac{A_{st1}}{0.387} = \frac{50.3}{0.387} = 130\text{mm}$$

取 $s = 120\text{mm} < s_{\max} = 200\text{mm}$ (满足构造要求)

即所配箍筋为 $\Phi 8 @ 120$

验算抗扭箍的配筋率

$$\rho_{sv} = \frac{2A_{st1}}{bs} = \frac{2 \times 50.3}{250 \times 120} = 0.34\% \geq \rho_{sv, \min} = 0.28 \frac{f_t}{f_{yv}} = 0.28 \frac{1.27}{300} = 0.12\%$$



【解】 4、抗扭纵筋的计算

$$(1) \text{ 按 } \zeta = \frac{f_y A_{stl}}{\mu_{cor}} / \frac{f_{yv} A_{stl}}{s} = \frac{f_y A_{stl} s}{f_{yv} A_{stl} \mu_{cor}} \text{ 得}$$

$$A_{stl} = \frac{f_{yv} u_{cor}}{f_y} \cdot \frac{A_{st1}}{s} = \frac{1.1 \times 300 \times 190 \times 440}{360} \cdot \frac{50.3}{120} = 484 \text{ mm}^2$$

(2) 验算抗扭纵筋配筋率

$$\rho_{tl} = \frac{A_{stl}}{bh} = \frac{484}{250 \times 500} = 0.387\% \geq \rho_{tl, \min} = 0.6 \sqrt{\frac{T}{Vb}} \frac{f_t}{f_y} = 0.6 \sqrt{2} \times \frac{1.27}{360} = 0.30\%$$

满足要求

(3) 选筋：选用 6 Φ 12 ($A_s = 678 \text{ mm}^2$)



6.3.2 弯剪扭构件承载力计算

一、弯剪扭构件的破坏特征

V 不起控制作用，且
 T/M 较小，配筋适量时



斜裂缝首先在弯曲受拉的
底部开裂，再发展



破坏时，底部受拉纵筋已屈服

T/M ——扭弯比

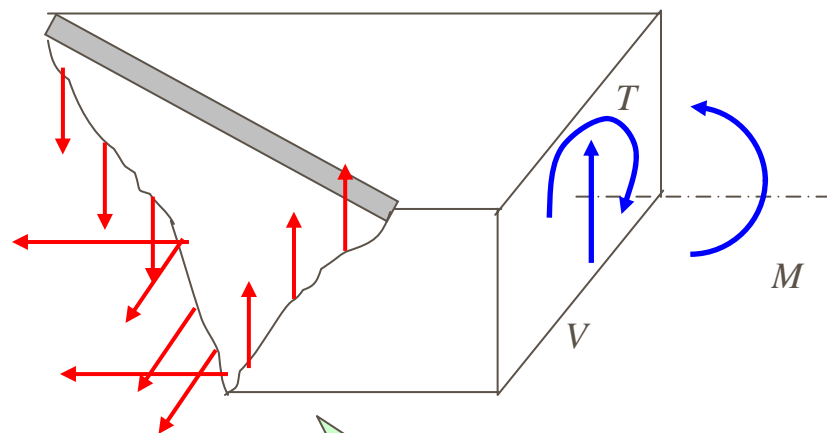

第 I 类型
“弯型破坏”



一、弯剪扭构件的破坏特征

M 不起控制作用



V 、 T 的共同工作使得一侧混凝土剪应力增大，一侧混凝土应力减小



剪应力大的一侧先受拉开裂，最后破坏， T 很小时，仅发生剪切破坏

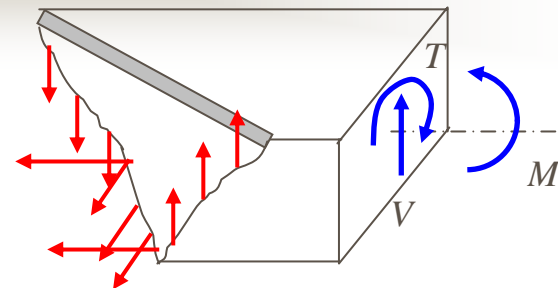

第 I 类型

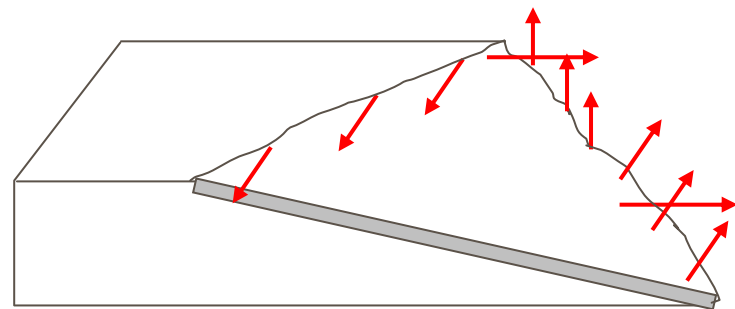

第 II 类型
“剪扭型破坏”



一、弯剪扭构件的破坏特征

V 不起控制作用， T/M 较大，且 $A_s' < A_s$ 时



由 M 引起的 A_s' 的压力不足以抵消 T 引起的 A_s' 中的拉力



由于 $A_s' < A_s$ ， A_s' 先受拉屈服，之后构件破坏

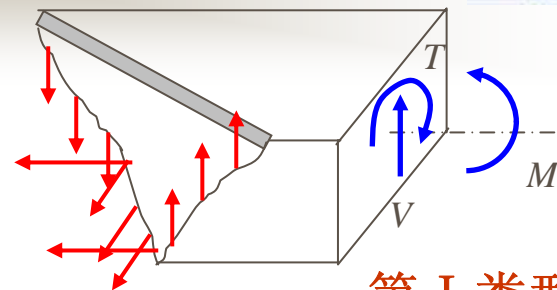

第 I 类型

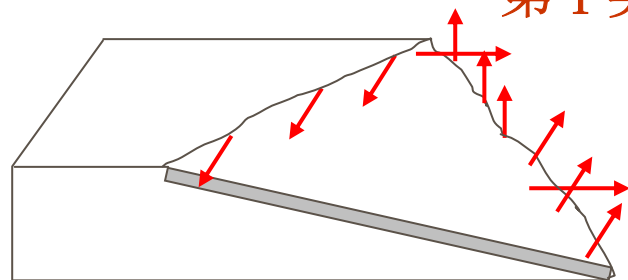

第 II 类型

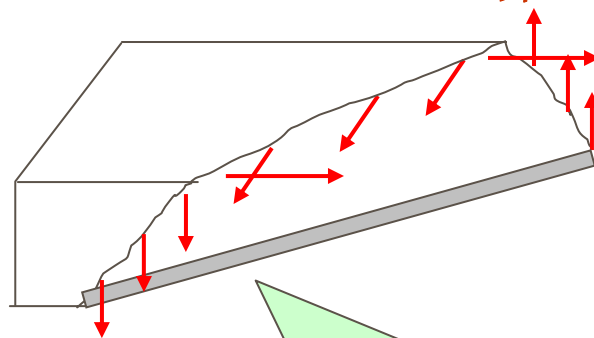

第 III 类型
“扭型破坏”



6.3.2 弯剪扭构件承载力计算

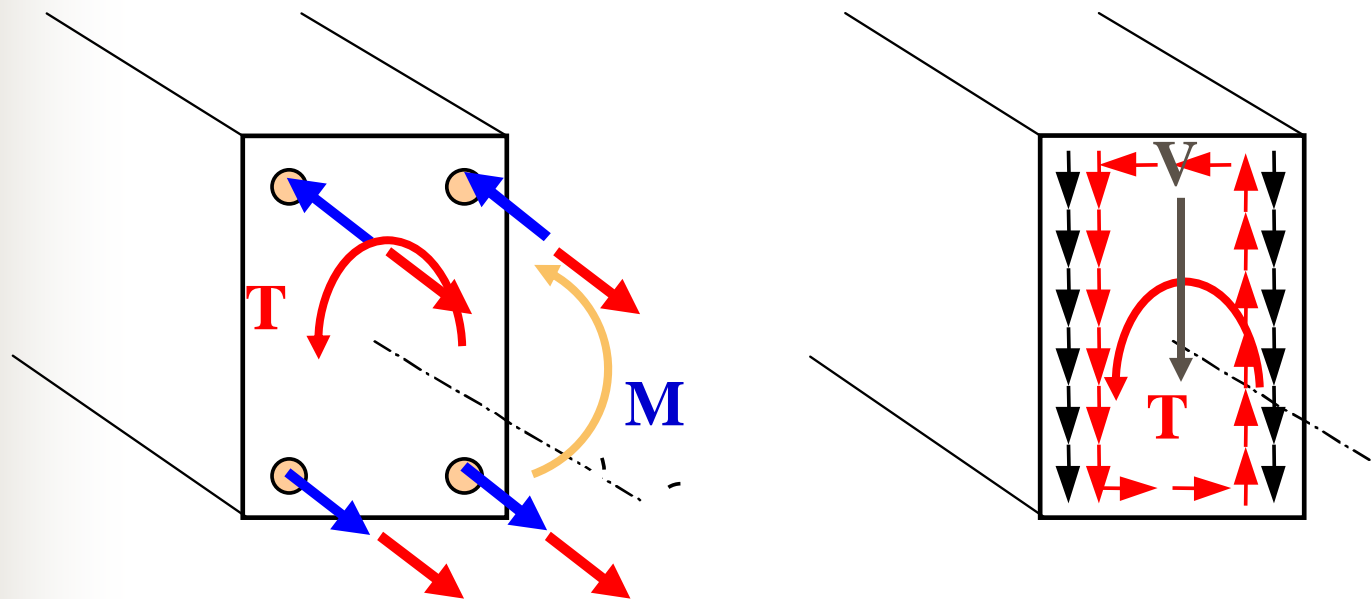

- **扭矩**使纵筋产生拉应力，与受弯时钢筋拉应力叠加，使钢筋拉应力增大，**从而会使受弯承载力降低**。
- 而扭矩和剪力产生的剪应力总会在构件的一个侧面上叠加，因此**承载力总是小于剪力和扭矩单独作用的承载力**。



6.3.2 弯剪扭构件承载力计算

试验表明：在**弯矩**、**剪力**和**扭矩**的共同作用下，各项承载力是**相互关联**的，其相互影响十分复杂。

《规范》建议的简化方法：

- **弯扭作用时，不考虑弯、扭的相关作用——分别计算其抗弯和抗扭承载力**
- **剪扭作用时，考虑只考虑 V_c 、 T_c 的相关性，不考虑 V_s 、 T_s 的相关性**

$$V_u = V_c + V_s$$

$$T_u = T_c + T_s$$

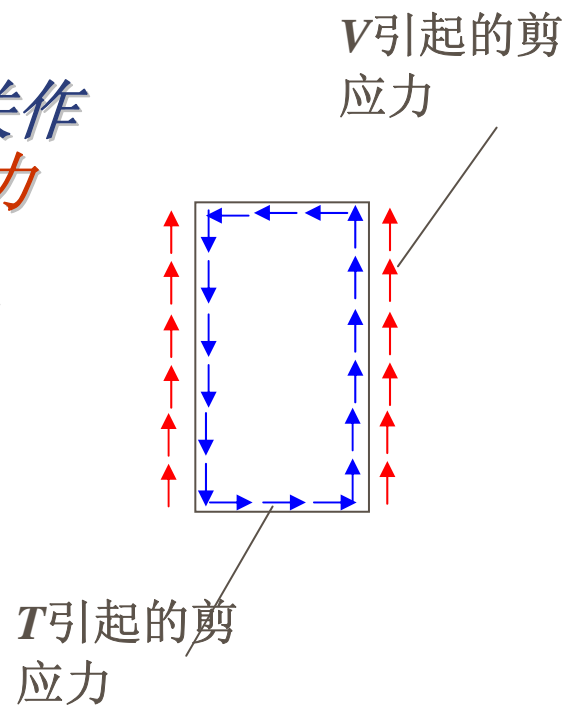



二、剪扭相关性

➤ 无腹筋构件的抗剪和抗扭承载力相关关系：

1 / 4圆弧规律

◆ 随着同时作用的扭矩增大，构件的抗剪的承载力逐渐降低；反之，随着同时作用的剪力增大，构件的抗扭承载力逐渐降低。

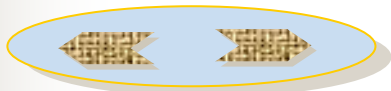
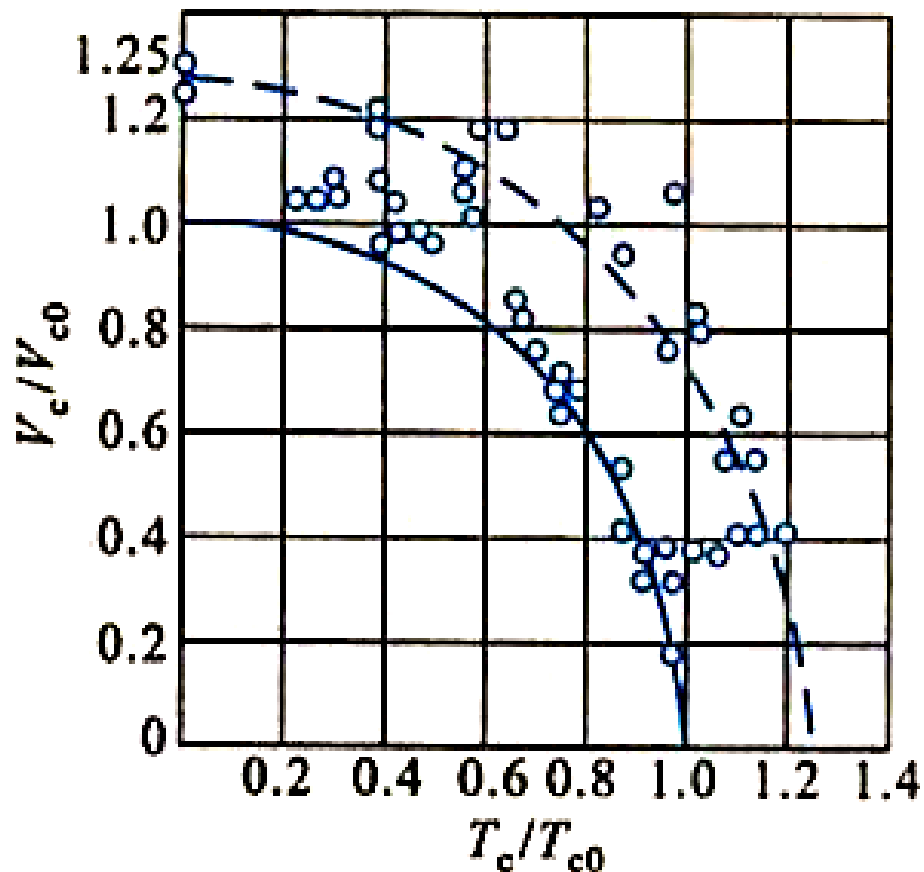



二、剪扭相关性——计算模式

$$0.5 < \frac{V_c}{V_{c0}} < 1.0, 0.5 < \frac{T_c}{T_{c0}} < 1.0 \text{ 时}$$

$$\frac{V_c}{V_{c0}} + \frac{T_c}{T_{c0}} = 1.5$$

$$\frac{T_c}{T_{c0}} = \beta_t$$

$$\beta_t = \frac{1.5}{1 + \frac{V_c}{T_c} \frac{V_{c0}}{T_{c0}}}$$

$$V_{c0} = 0.7 f_t b h_0$$

$$T_{c0} = 0.35 f_t W_t$$

$$\beta_t = \frac{1.5}{1 + \frac{V_c W_t}{T_c b h_0}}$$

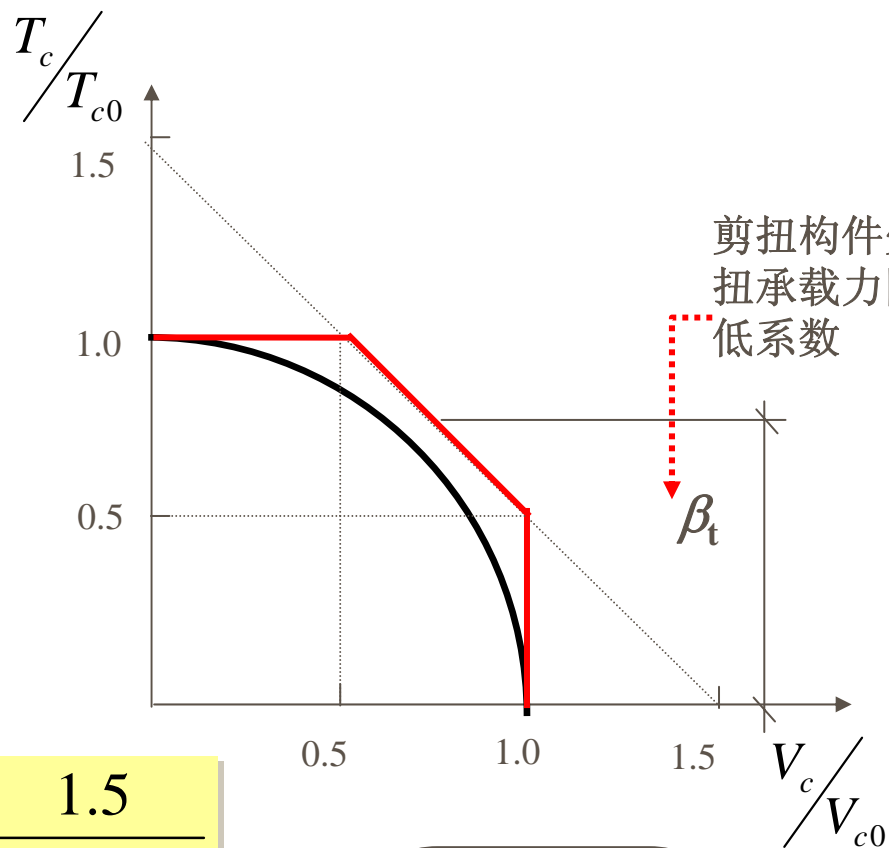

剪扭构件受扭承载力降低系数

β_t

均布荷载作用



二、剪扭相关性——计算模式

集中荷载

$$\beta_t = \frac{1.5}{1 + 0.2(\lambda + 1) \frac{V_c W_t}{T_c b h_0}}$$

$$\beta_t \leq 0.5 \text{ 时, } \frac{V_c}{V_{c0}} = 1.0$$



扭矩对抗剪承载力无影响

$$\beta_t = 1.0 \text{ 时, } \frac{T_c}{T_{c0}} = 1.0$$



剪力对抗扭承载力无影响

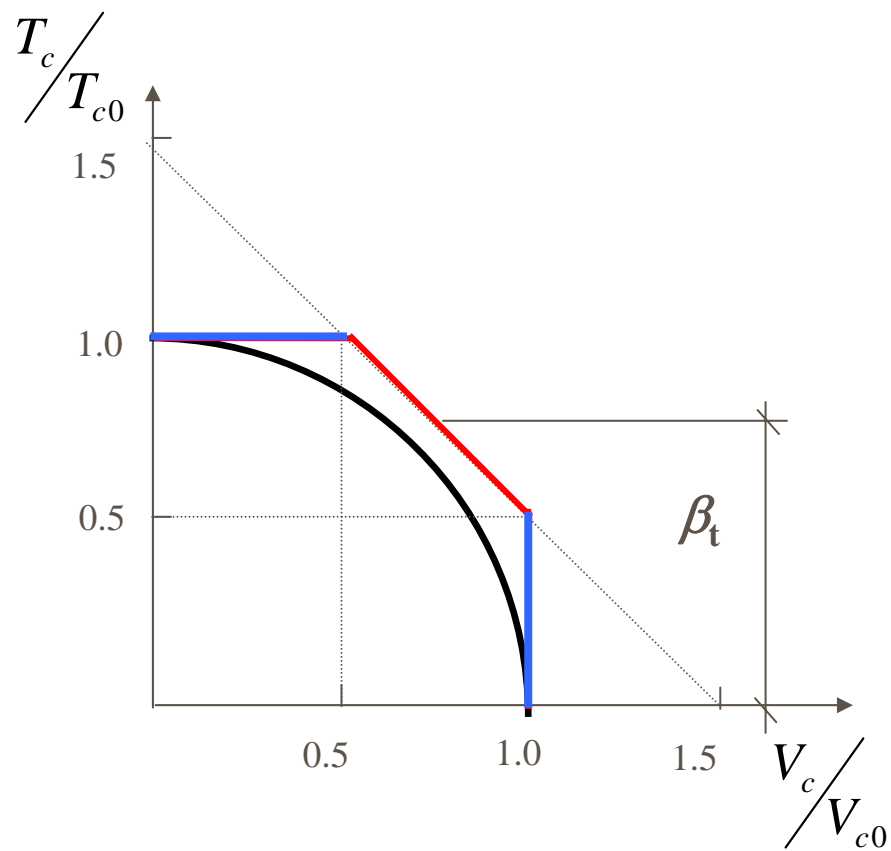



三、弯剪扭构件承载力计算

1. 矩形截面弯剪扭构件承载力计算

➤ 剪扭构件承载力计算

(1) 按抗剪承载力计算需要的抗剪箍筋 nA_{sv1}/s_v

$$V = 0.7 f_t b h_0 (1.5 - \beta_t) + 1.25 f_{yv} \frac{nA_{sv1}}{s_v} h_0$$

$$\beta_t = \frac{1.5}{1 + 0.5 \frac{VW_t}{Tbh_0}}$$

集中荷载作用下的独立梁

$$0.5 \leq \beta_t \leq 1.0$$

$$V = \frac{1.75}{\lambda + 1} (1.5 - \beta_t) f_t b h_0 + f_{yv} \frac{nA_{sv1}}{s_v} h_0$$

$$\beta_t = \frac{1.5}{1 + 0.2(\lambda + 1) \frac{VW_t}{Tbh_0}}$$

$$1.4 \leq \lambda \leq 3$$

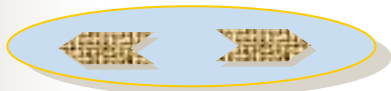



1. 矩形截面弯剪扭构件承载力计算

➤ 剪扭构件承载力计算

(1) 按抗剪承载力计算需要的抗剪箍筋 nA_{sv1} / s_v

(2) 按抗扭承载力计算需要的抗扭箍筋 A_{st1} / s_t

$$T = 0.35\beta_t f_t W_t + 1.2\sqrt{\zeta} \frac{f_{yv} A_{st1} A_{cor}}{s_t}$$

...6-27

(3) 按照迭加原则计算抗剪扭总的箍筋用量 A_{st1}^* / s

$$\frac{A_{st1}^*}{s} = \frac{A_{sv1}}{s_v} + \frac{A_{st1}}{s_t}$$

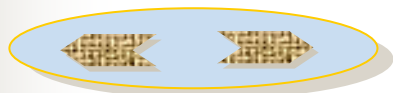
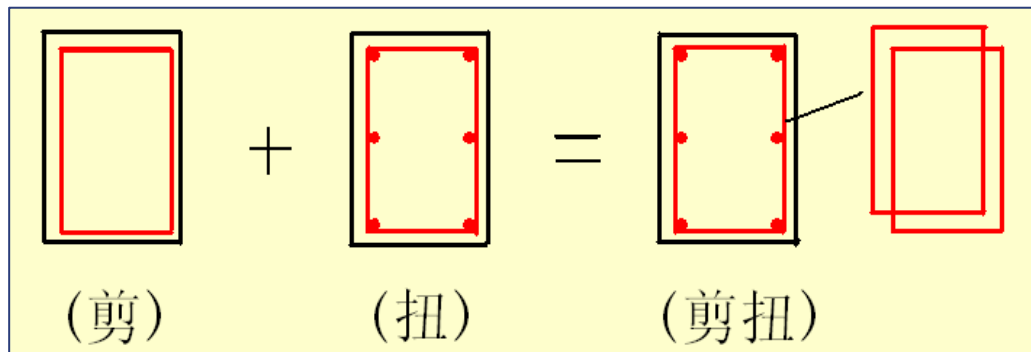



● 弯、扭构件承载力计算

不考虑弯扭相关性，分别按纯弯和纯扭构件计算和配筋，然后将钢筋面积叠加。

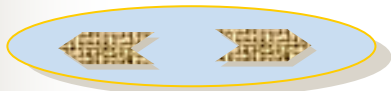
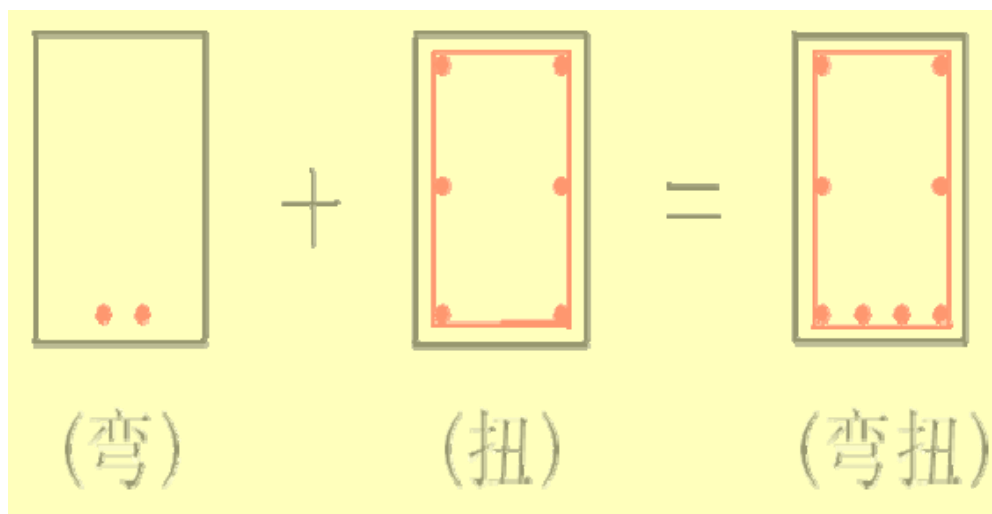



弯、剪、扭构件承载力计算

弯矩 —— 按纯弯构件计算；
 剪力 } 按剪、扭构件计算；
 扭矩 } 验算是否要考虑剪、扭相关性。
 分别计算，然后将钢筋面积叠加。

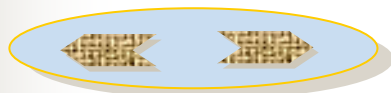
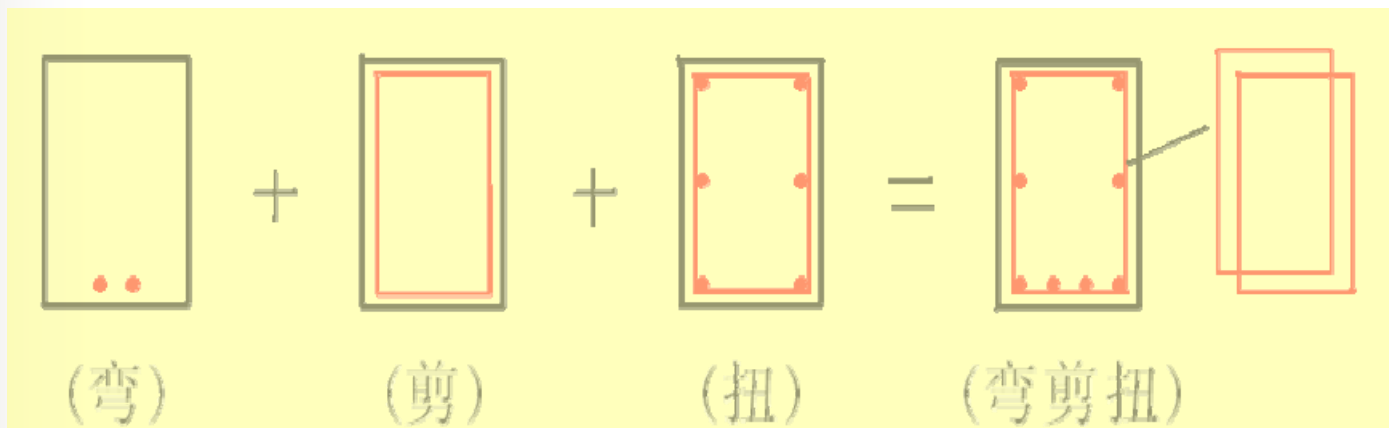



2. T形和I形截面弯、剪、扭构件承载力计算

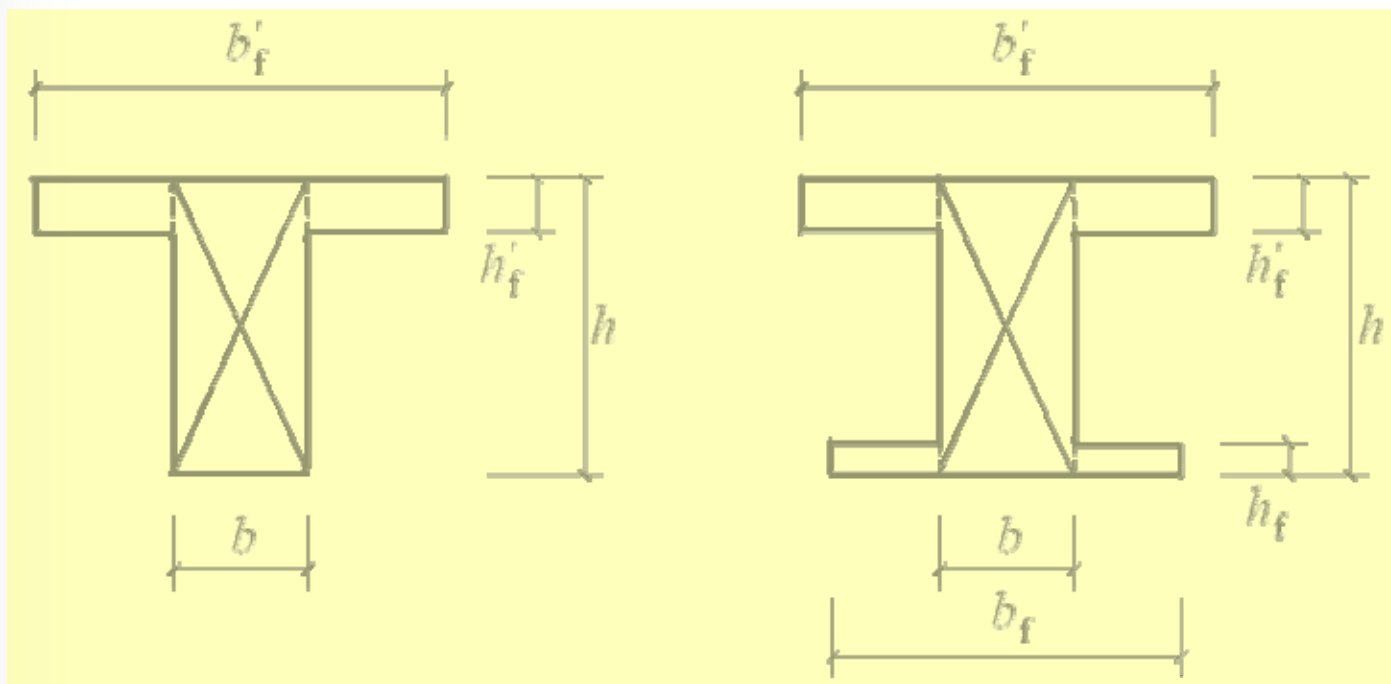

- 计算原则：
- 1) 弯矩按纯弯计算；
 - 2) 剪力由腹板单独承担；
 - 3) 扭矩由腹板和翼缘共同承受。

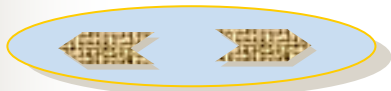



➤ 扭矩分配:

腹板

$$T_w = \frac{W_{tw}}{W_t} T$$

受压翼缘

$$T'_f = \frac{W'_{tf}}{W_t} T$$

受拉翼缘

$$T_f = \frac{W_{tf}}{W_t} T$$

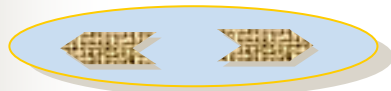



式中，

$$W_{tw} = \frac{b^2}{6}(3h - b)$$

$$W_{tf}' = \frac{h_f'}{2}(b_f' - b)$$

$$W_{tf} = \frac{h_f^2}{2}(b_f - b)$$

$$W_t = W_{tw} + W_{tf}' + W_{tf}$$

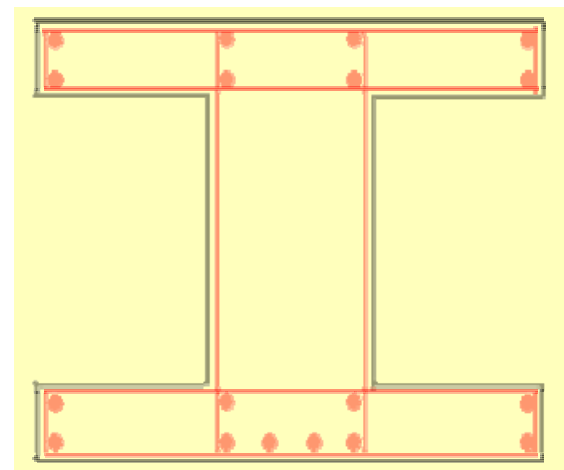

截面各部分受力：

翼缘 —— 纯扭； 腹板 —— 剪扭；

全截面 —— 弯剪扭分别配筋再叠加。

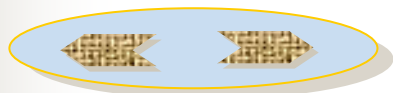



3. 箱形截面弯剪扭构件承载力计算

➤ (1) 一般剪扭构件

$$V \leq (1.5 - \beta_t) 0.7 f_t b h_0 + 1.25 f_{yv} \frac{A_{sv}}{S} h_0 \quad \dots 6-29$$

$$T \leq 0.35 \alpha_h f_t W_t + 1.2 \sqrt{\zeta} f_{yv} \frac{A_{st1} A_{cor}}{S} \quad \dots 6-30$$

➤ (2) 集中力作用下的独立剪扭构件:

$$V \leq (1.5 - \beta_t) \frac{1.75}{\lambda + 1} f_t b h_0 + 1.25 f_{yv} \frac{A_{sv}}{S} h_0 \quad \dots 6-31$$

$$T \leq 0.35 \alpha_h f_t W_t + 1.2 \sqrt{\zeta} f_{yv} \frac{A_{st1} A_{cor}}{S} \quad \dots 6-32$$

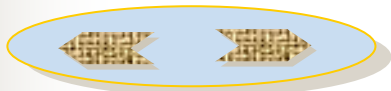



6.3.3 压弯剪扭构件承载力计算

- ◆ 按偏心受压构件进行正截面承载力计算确定纵筋 A_s 、 $A's$;
- ◆ 剪扭承载力按下式计算确定配筋，然后再将钢筋叠加。

1. 受剪承载力

$$V \leq 1.5(1 - \beta_t) \left(\frac{1.75}{\lambda + 1} f_t b h_0 + 0.07N \right) + f_{yv} \frac{A_{sv}}{s} h_0 \quad \dots 6-33$$

2. 受扭承载力

$$T \leq \beta_t \left(0.35 f_t + 0.07 \frac{N}{A} \right) W_t + 1.2 \sqrt{\zeta} f_{yv} \frac{A_{st1} A_{cor}}{s} \quad \dots 6-34$$

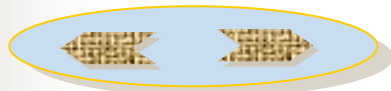



6.3.4 受扭构件公式的适用条件及构造要求

1. 截面限制条件

➤ 为了**防止超筋**,要求截面尺寸满足

当 $h_w/b \leq 4$ 时,
$$\frac{V}{bh_0} + \frac{T}{0.8W_t} \leq 0.25\beta_c f_c$$

当 $h_w/b \geq 6$ 时,
$$\frac{V}{bh_0} + \frac{T}{0.8W_t} \leq 0.20\beta_c f_c$$

...6-35

当 $4 < h_w/b < 6$ 时, 按线性内插法确定。

注意:

如不满足式(6-35)的要求, 则需加大构件截面尺寸, 或提高混凝土强度等级。





2. 构造配筋界限

$$\frac{V}{bh_0} + \frac{T}{W_t} \leq 0.7f_t$$

...6-36

3. 最小配筋率

受剪及受扭箍筋要满足:

$$\rho_{sv} \geq \rho_{sv,min} = 0.28f_t / f_{yv}$$

...6-37

注意:

受扭纵筋要满足:

$$\rho_{tl} \geq \rho_{tl,min} = 0.6 \frac{f_t}{f_{yv}} \sqrt{\frac{T}{Vb}}$$

...6-38

◆ 纵筋的配筋率应不小于受弯时的最小配筋率和受扭时最小配筋率之和。

当 $T/Vb > 2$ 时, 取 $T/Vb = 2$

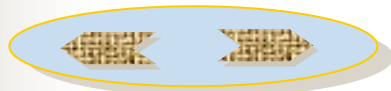



4. 钢筋的构造要求

- 受扭箍筋应采用封闭式箍筋，做法见下图。

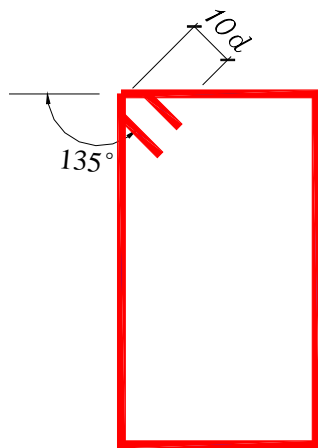

- 受扭钢筋应**对称**设置于截面周边，**角点**处应有**纵筋**。

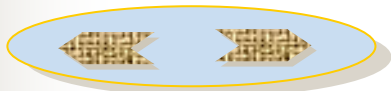



弯剪扭构件计算方法确定

(1) 当 $V \leq 0.35 f_t b h_0$ 或 $V \leq \frac{0.875}{\lambda + 1} f_t b h_0$ 时，可按

受弯构件的正截面受弯承载力和纯扭构件的受扭承载力分别进行计算。

(2) 当 $T \leq 0.175 f_t W_t$ 时，可按受弯构件的正截面受弯承载力和斜截面的受剪承载力分别进行计算。

(3) 其它情况按弯剪扭构件进行承载力计算。



弯剪扭构件承载力公式应用

1. 截面设计

► 矩形截面或箱形截面为例----**步骤一：剪扭钢筋**

$$\text{验算截面尺寸: } \frac{T}{0.8W_t} + \frac{V}{bh_0} \leq 0.25\beta_c f_c$$



$$\text{计算: } \beta_t = \frac{1.5}{1 + 0.5 \frac{VW_t}{Tbh_0}}, (\beta_t = \frac{1.5}{1 + 0.2(\lambda + 1) \frac{VW_t}{Tbh_0}})$$



分别按照剪、扭公式计算相应配筋



弯剪扭构件承载力公式应用

1. 截面设计

► 矩形截面或箱形截面为例----**步骤二：受弯钢筋**

按照**单筋矩形截面受弯构件**的正截面承载力计算公式计算受弯钢筋（纵筋）



弯剪扭构件承载力公式应用

1. 截面设计

► 矩形截面或箱形截面为例----步骤三：截面配筋

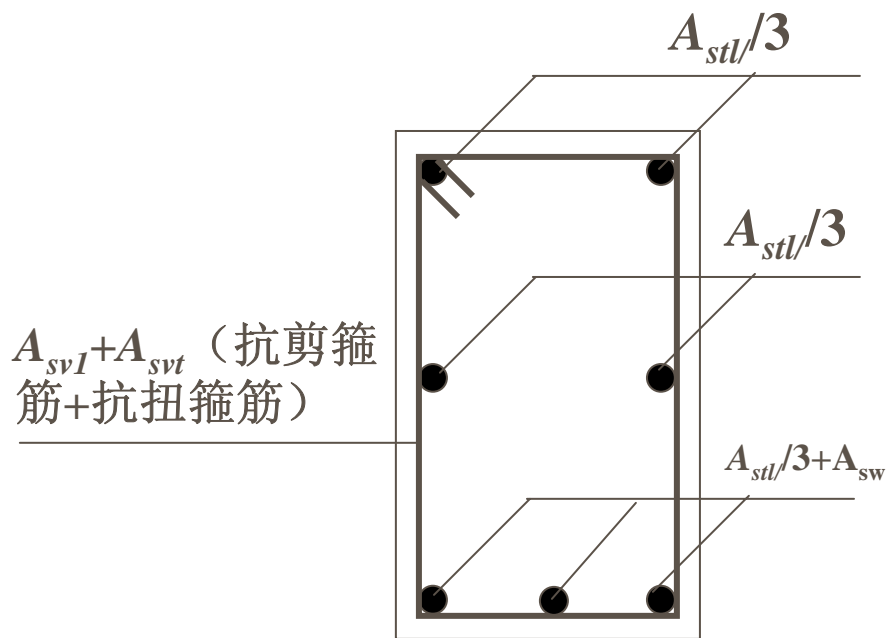



弯剪扭构件承载力公式应用

2. 承载力复核

■ 矩形截面或箱形截面 ---- 步骤一：抗弯承载力

确定抗弯和抗扭纵筋



确定抗弯承载力

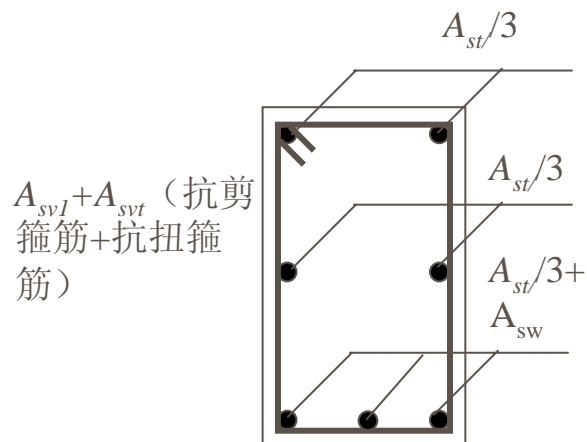



弯剪扭构件承载力公式应用

2. 承载力复核

■ 矩形截面或箱形截面 ---- 步骤二：确定抗扭、抗剪箍筋

$$\zeta = \frac{A_{stl} f_y s}{A_{st1} f_{yv} \mu_{cor}}$$



$$A_{st1}$$



$$A_{sv1}$$

$A_{svl} + A_{svt}$ (抗剪箍筋+抗扭箍筋)

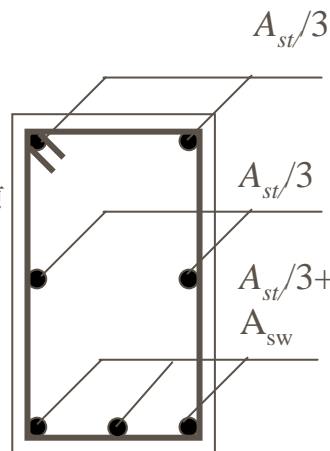

$$\rho_{stl \min} = 0.6 \sqrt{\frac{T_u}{V_u b}} \frac{f_t}{f_y}, \rho_{svt \min} = 0.28 \frac{f_t}{f_{yv}}$$



弯剪扭构件承载力公式应用

2. 承载力复核

■ 矩形截面或箱形截面 ---- 步骤三：确定剪扭承载力

假定 $0.5 \leq \beta_t \leq 1.0$



按照相关公式求 V_u 、 T_u



$$\frac{V_u}{bh_0} + \frac{T_u}{0.8W_t} \leq 0.25\beta_c f_c$$



$A_{svl} + A_{svt}$ (抗剪箍筋+抗扭箍筋)

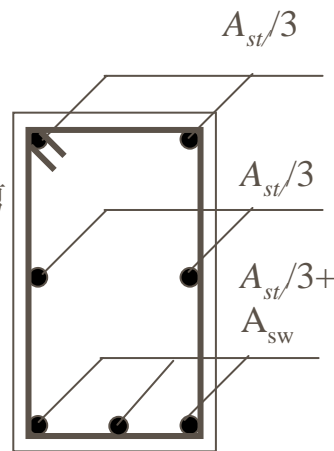

若 $\rho_{stl} < 0.6 \sqrt{\frac{T_u}{V_u b} \frac{f_t}{f_y}}$, 不考虑纵筋的作用; 若 $\rho_{svt \min} < 0.28 \frac{f_t}{f_{yv}}$, 不考虑箍筋的作用



§ 6.3.5 设计例题

【例6-1】 已知一均布荷载作用下钢筋混凝土T形截面弯剪扭构件，截面尺寸 $b'_f = 400\text{mm}$ ， $h'_f = 80\text{mm}$ ， $b \times h = 200\text{mm} \times 450\text{mm}$ ，如图6-15所示。构件所承受的弯矩设计值 $M = 54\text{kN}\cdot\text{m}$ ，剪力设计值 $V = 64\text{kN}$ ，扭矩设计值 $T = 6\text{kN}\cdot\text{m}$ 。采用混凝土C20($f_c = 9.6\text{N}/\text{mm}^2$ 、 $f_t = 1.1\text{N}/\text{mm}^2$)，纵向受力钢筋采用HRB335级钢筋($f_y = 300\text{N}/\text{mm}^2$)，箍筋采用HPB235级($f_y = 210\text{N}/\text{mm}^2$)，试计算其配筋。

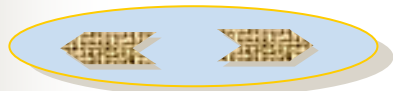



➤ 6.4 公路桥涵工程中受扭构件承载力计算

6.4.1 矩形和箱形截面纯扭构件

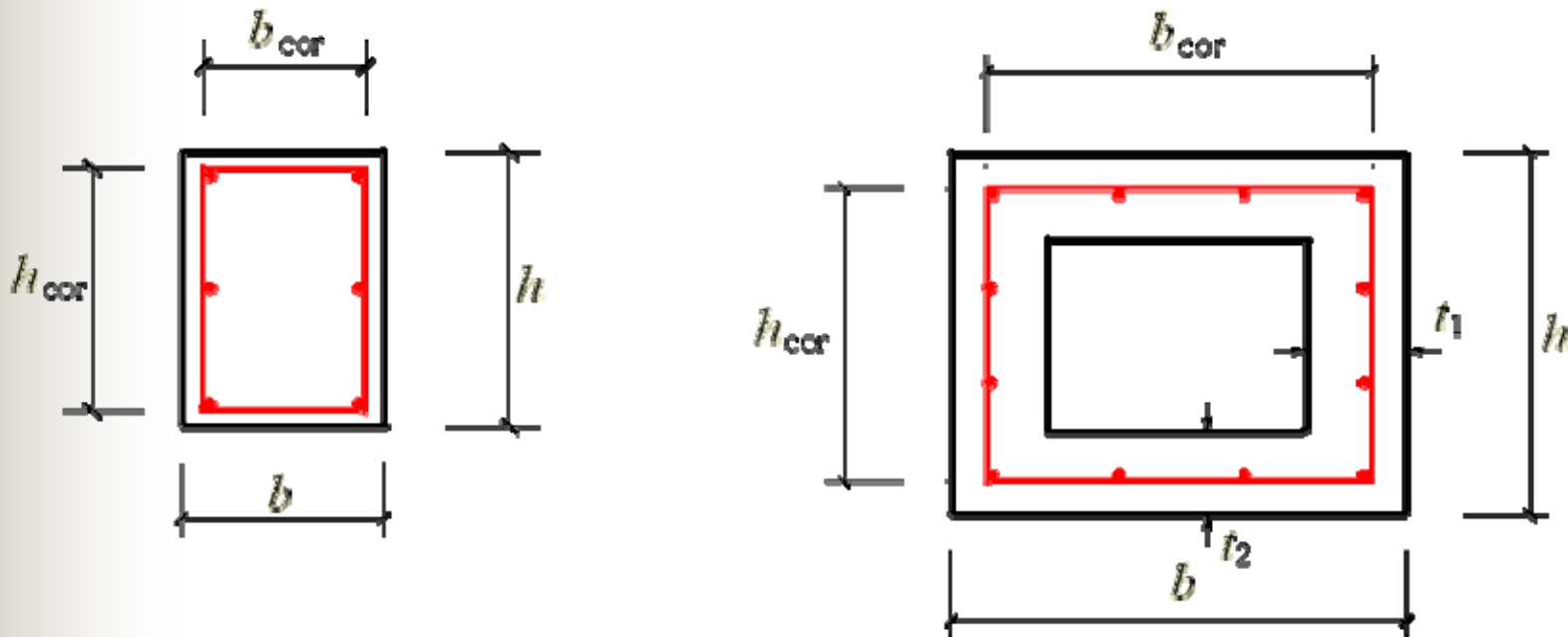

$$\gamma_0 T_d \leq 0.35 \beta_a f_{td} W_t + 1.2 \sqrt{\zeta} \frac{f_{sv} A_{sv1} A_{cor}}{S_v}$$

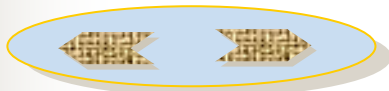



f_{sv} — 箍筋的抗拉强度设计值；

ζ — 抗扭纵筋与箍筋的配筋强度比， $0.6 \leq \zeta \leq 1.7$ 。

按公式（6-33）计算的箱形截面构件应满足
 $t_2 \geq 0.1b$ 和 $t_1 \geq 0.1h$ 的条件。

6.4.2 矩形和箱形截面剪扭和弯剪扭构件

➤ 剪扭构件

不考虑剪扭相关性，剪力和扭矩分别计算，抗扭按下公式计算

$$\gamma_0 T_d \leq 0.35 \beta_a \beta_t f_{td} W_t + 1.2 \sqrt{\zeta} \frac{f_{sv} A_{sv1} A_{cor}}{S_v}$$

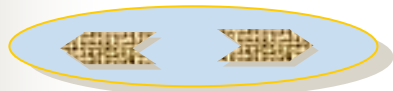



式中—剪扭构件混凝土抗扭承载力降低系数

$$\beta_t = \frac{1.5}{1 + 0.5 \frac{V_d W_t}{T_d b h_0}} \quad \dots 6-42$$

当 $\beta_t < 0.5$ 时,取 $\beta_t = 0.5$;当 $\beta_t > 1.0$ 时,取 $\beta_t = 1.0$ 。

➤ 弯剪扭构件

弯矩按纯弯计算，剪力和扭矩也分别计算再叠加。

6.4.3 矩形和箱形截面受扭构件截面尺寸应满足的条件

$$\frac{\gamma_0 V_d}{b h_0} + \frac{\gamma_0 T_d}{W_t} \leq 0.51 \times 10^{-3} \sqrt{f_{cu,k}} \quad \dots 6-46$$

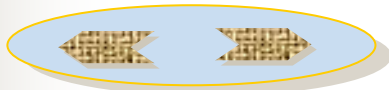



6.4.4 可不进行构件抗扭承载力计算的条件

$$\frac{\gamma_0 V_d}{bh_0} + \frac{\gamma_0 T_d}{W_t} \leq 0.5 \times 10^{-3} f_{td} \quad \dots 6-47$$

6.4.5 配筋条件

- 箍筋的配筋率
剪扭构件

$$\rho_{sv} \geq (2\beta_t - 1) \left(0.055 \frac{f_{cd}}{f_{sd}} - c \right) + c$$

式中，当采用R235级钢筋时 c 值取0.0018，
当采用HRB335级钢筋时取0.0012。

纯扭构件

$$\rho_{sv} \geq 0.055 \frac{f_{cd}}{f_{sd}}$$





➤ 纵向钢筋的配筋率

剪扭不应小于受弯构件纵向受力钢筋的最小配筋率和受扭构件纵向受力钢筋的最小配筋率之和，不应小于 $38f_{td}/f_{sd}$ ，也不应小于0.15%。

抗扭纵筋最小配筋率为

纯扭时

$$0.08f_{cd}/f_{sd}$$

弯扭时

$$0.08(2\beta_t - 1)f_{cd}/f_{sd}$$

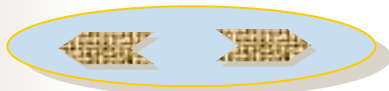



➤ 6.5 小结

