

Diagnosis of business health

Diagnostika zdraví podniku

J. HRON

Czech University of Agriculture, Prague, Czech Republic

Abstract: Every business grows, develops and dies within its life-cycle, dependent on its relations with the external and internal environment. Its “flexibility” and ability to “influence” both the internal and external environment are indications of its “health”. A healthy business is characterized by those parameters of its structure and behaviour that encourage its further development in any given environment. The “health” of the business is determined by the level of its homeostasis with the internal and external environment. This kind of health may reach various levels. It is therefore necessary to diagnose it, and to suggest changes in its business strategy and individual parameters. The health of a business should therefore represent a prerequisite of effective behaviour.

Key words: business, health, internal and external environment, development, effective behaviour

Abstrakt: Každý podnikatelský subjekt vzniká, rozvíjí se a zaniká v rámci svého životního cyklu v závislosti na jeho vztazích k vnějšmu a vnitřnímu prostředí. Schopnost „přizpůsobivost“ se a „ovlivňovat“ vnitřní a vnější prostředí je příznakem jeho „zdraví“. Zdravý podnikatelský subjekt je charakterizován takovými parametry své struktury a chování, které umožňují jeho rozvoj v daném prostředí. „Zdraví“ podnikatelského subjektu je určováno úrovní homeostáze podnikatelského subjektu s jeho vnitřním a vnějším prostředím. Toto zdraví může být na nejrůznější úrovni, a proto je třeba ho diagnostikovat a případně navrhnout změny ve strategii podnikatelského subjektu a jednotlivých jeho parametrů tak, aby jeho zdraví bylo předpokladem efektivního chování.

Klíčová slova: podnikatelský subjekt, zdraví, vnitřní a vnější prostředí, rozvoj, efektivní chování

INTRODUCTION

Every business grows, develops and dies within its life-cycle, dependent on its relations with the external and internal environment. Its “flexibility” and ability to “influence” both the internal and external environment are indications of its “health”. A healthy business is characterized by those parameters of its structure and behaviour that encourage its further development in any given environment.

The “health” of the business is determined by the level of its homeostasis with the internal and external environment. This kind of health may reach various levels. It is therefore necessary to diagnose it, and to suggest changes in its business strategy and individual parameters. The health of a business should therefore represent a prerequisite of effective behaviour.

METHODICAL APPROACH

The aim of this paper is to suggest the methodological process which would determine the “health” of a busi-

ness, and to propose the “therapy” for its effective behavioural development. This is based on methods of organizational systems theory and strategic management, as well as the utilization of statistically obtained behavioural norms of effectively acting organizational systems of business.

RESULTS AND DISCUSSION

The way a business behaves provides a basis for determining its health, because it is the consequence of its ability to adapt to the changes in the internal and external environment and to appropriately influence both environments as a result of its own strategy. The criterion of behaviour evaluation, its efficiency and thus the health of the business is its comparison to the behaviour of the most successful businesses operating under comparable conditions (Hala, Whitlam 1997).

The process of diagnosis and health therapy of a business can be performed in the following sequence:

- A. Qualitative analysis of the current strategy
- B. Quantitative analysis of behaviour

The contribution presented at the international conference Agrarian Perspectives XIII (CUA Prague, September 22, 2004) and is based on findings gathered within the project NAZV QF 3261.

- C. Evaluation of strategy and behaviour
- D. Therapy proposal

Qualitative analysis of the business's current strategy

The basics of qualitative analysis of the business's current strategy is the analysis of both the internal and external environment as well as the analysis of interests groups by performing a SWOT analysis (Czerniawska, Potter 1998). This procedure can be schematically depicted in the following way (Figure 1).

The individual progressive steps are very arduous and they demand utilization of the existing methods of strategic management (Band 1994). The description of the factors of external environment analysis within the STEP analysis may serve as an example.

The individual factors can be divided into the following four segments:

Social

- includes factors connected with lifestyle and shared values
- the subjects of analysis include for instance:

- demography
- income distribution
- population mobility
- lifestyle
- level of education
- attitudes to work and leisure

Technological

- includes factors related to the development of production technology, materials, processes and know-how
- the subjects of analysis include for example:
 - governmental expenditure on science and research
 - new discoveries, inventions and patents
 - transfer of technologies
 - rate of production technology obsolescence

Economic

- includes factors related to the flow of money, goods, services, information and energy
- the subjects of analysis include for example:
 - development trend of gross domestic product
 - business life cycle
 - money supply, interest rate
 - inflation/deflation
 - unemployment
 - availability of energy and energy costs

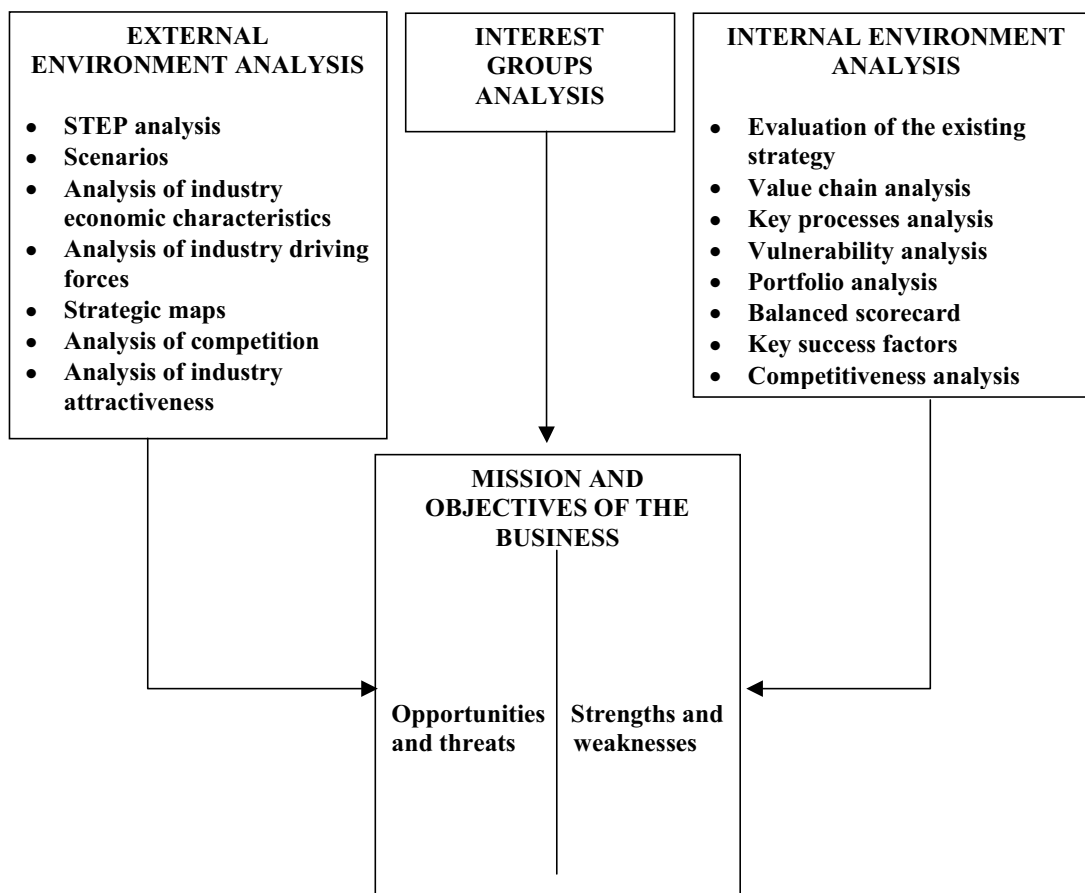

Figure 1. Qualitative analysis of the current strategy

Political (political-legal)

- includes factors related to the distribution of authority among people, including behaviour of home and foreign governments

The subjects of analysis include for example:

- Government stability
- Foreign trade regulation
- Tax policies
- Monopoly legislation
- Environmental protection

B. Quantitative analysis of business subject's behaviour

The resulting behaviour of a business's organizational system depends on the level of the individual factors and parameters, as well as on their sensible arrangement. The quantification then results from expert evaluation by the means of points score method, then from a conversion to absolute values in the interval 0–1, and eventually from an index expression of the real level of the individual parameters in relation to the normative level.

1. Analysis of business's organizational system

Every organizational process of a business, and thus also every company, is connected with the external environment by the means of inputs, represented by variables (*a*) in Table 1. In the internal environment, it comes to

material-energetic and information transformations in the range of inner structures represented by structural variables (*C*). This is influenced by the company management, represented by the variable (*D*). The inner transformations are implemented through marketing management (*M*) and it is manifested in the resulting behaviour.

The relationships of the organizational systems of businesses are diagrammatically shown in Table 1 and Figure 2 (below).

Materials and energies arrive to organizational systems through inputs. These materials and energies are transformed, together with the internal resources, by the means of structural variables. This is done under the influence of company management variables and marketing management variables. The company and marketing management variables are related to these processes by way of a feedback system, where they function as buffers that affect potential transformations by the values *F* and *R*; where:

$$F = 1 - D$$

$$R = 1 - M$$

This means that the inputs are changed by Δa , which is created by $\Delta_f a$ and $\Delta_r a$

$$\Delta_f a = Fe$$

$$\Delta_r a = Re$$

From the above proposition that, by exerting negative feedbacks which are typical for all live organisms with homeostatic behaviour, the following may be deduced:

Table 1. Resulting behaviour of organizational system

External environment		<i>a</i>
Organizational system of businesses and/or companies	Natural – technical and human resources	<i>C</i>
	Company management variable	<i>D</i>
	Marketing management variable	<i>M</i>
Resulting behaviour		<i>e</i>

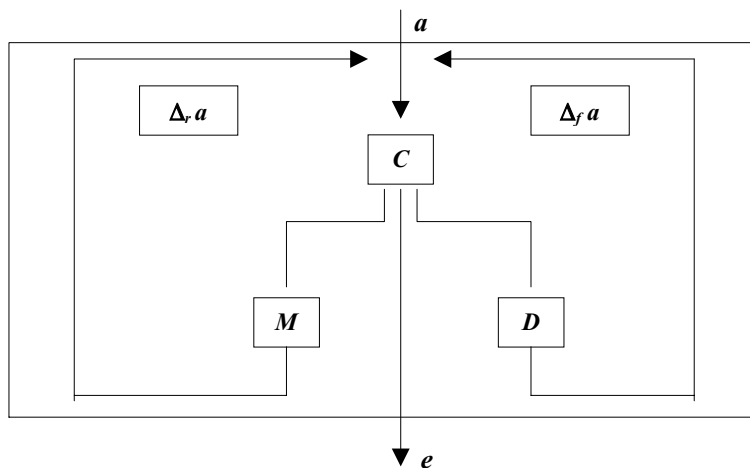

Figure 2. Factors affecting behaviour of organizational systems

$$e = C [a(\Delta_j a + \Delta_j a)] = C [a(Fe + Re)]$$

from which:

$$e = \frac{c}{1 + C(F + R)} \cdot a$$

where:

- e – resulting behaviour variable
- a – external environment variable
- $F = 1 - D$ – company management variable
- $R = 1 - M$ – marketing management variable
- C – structural variable.

Every strategy must also respect the time factor, which applies throughout all the processes and transformations. It plays a much bigger role in material-energetic transformation processes than it does in information processes. The time delay evident in the behaviour of organizational systems in companies, and represented by the delay from introduction of a change to its demonstration is very important.

This kind of delay can be concluded from the model of behaviour (e_t), which can be expressed in whichever point in time (t) as the sum of the balanced state and the variance from this state:

$$e_t = \frac{C \cdot a}{1 + C(F + R)} - [C(F + R)]^t \cdot f_o$$

where:

- e_t – value of the resulting behaviour in the respective year
- f_o – initial variance of the resulting behaviour from the target state

This relationship implies that the state of balance corresponds to the maximum utilization of all conditions, which means to the target state from which it differs, by the variance. In accord with the principle of homeostasis, the organizational system progressively eliminates variances during the time series, by increasing the resources' utilization. If the environment and its conditions are changed, utilization of these conditions can be then understood as the target state, and the current state is then regarded as a deflection from the balanced state.

The resulting variance (f_o) must then be eliminated. This results in the time delay itself.

This time delay can be thus concluded from the relation:

$$t = \frac{\log f_t - \log f_o}{\log [C(F + R)]}$$

where f_t – final variance from the target resulting behaviour.

The purpose of the above relationship is to draw attention to:

- The inertia of the individual processes,
- The creation of harmony among the individual measures in the legislative sphere, and thus forming preconditions for handling all areas of organizational systems (otherwise the prevailing operating style remains – as well as the old production criteria, social criteria, and economic criteria)
- The necessity of introducing immediate changes, so the desired behaviour happens within a realistic time delay

Delimitation of company behaviour factors

The relationship

$$e = \frac{C \cdot a}{1 + C(F + R)} - [C(F + R)]^t \cdot f_o$$

implies that the individual factors are inevitable to quantify within the interval $\langle 0-1 \rangle$ and using the methods of strategic management as well as theory of organizations.

External behaviour factors (a)

Among the external environment factors, there may be included the following factors in compliance with the Porter model (Figure 3).

2. Analysis of internal environment factors

Internal environment factors (C, D, M)

The level of internal environment factors influences the level of transformational environments, and it is related to the internal variables

- Structural variable (C)
- Company management variable (D)
- Marketing management variable (M).

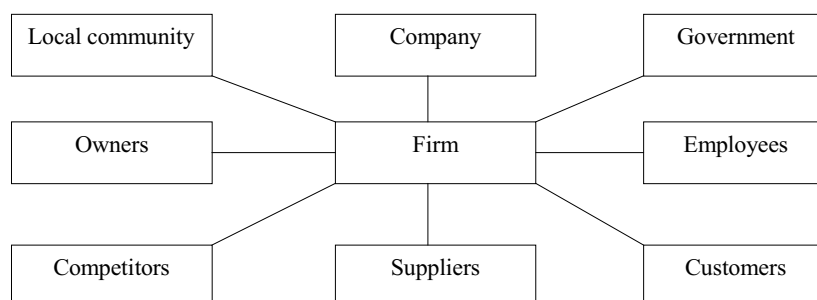

Figure 3. External environment factors of businesses

The structural variable C is formed by the factors affecting technical, organizational and operating capacity of the organizational system elements.

Technical factors – affect the level of technical capacity, show the quality of technical facilities, provide for effective utilization of technical and natural resources, labour productivity and reliability of processes (Hron 1992).

Technological factors – affect the level of organizational capacity, directly relate to the concentration of the means of production, specialization of processes and stability of the company behaviour (Hron 1992).

Stability of behaviour is conditioned either by diversification of adequately concentrated processes in unstable environment (inter-company specialization) or sufficient concentration of a specialized process in stable environment (company specialization).

2.1. Factors of organizational and operational units creation

During the creation of organizational and operational structures of agricultural enterprises, there are all kinds of factors evident. Among the crucial factors, it is important to respect the following:

- environment in which the business is located and thus the impact of external forces,
- business size,
- character of basic activities,
- territorial allocation of the business,
- qualification of managers, managerial methods used,
- characteristics and costliness of the individual management activities,
- managerial philosophy of the managers, etc.

In general, these factors may be divided into:

- 1) Internal factors that influence mainly the size of organization units.
- 2) External factors that influence the hierarchical arrangement of organization units.
- 3) Integrating factors that condition the level of managerial process within the organization units.
- 4) Make-up factors that respect the particular production conditions of agricultural enterprises.

2.1.1. Internal factors

They characterize the level of individual organization systems' areas of agricultural enterprises.

Technical capacity - v -

Characterizes the level of production-technical baseline of agricultural enterprises and its "technical" facilities that are expressible by the indicator of basic resources value (agricultural production per hectare of agricultural land).

Organization capacity - o -

Organization capacity of manual workers characterizes the level of organization-economic area of enterprises and expresses the amount of the means of production in

various formulations controlled by a single manpower in scope of production processes.

Span of control - q -

Span of control of the managers characterizes the level of managerial superstructure within enterprises. It is expressed by the number of direct subordinates of a single manager. This capacity affects the size of control units. Optimal number of workers is 4–6.

2.2. External factors

The external factors affect the hierarchical arrangement of organization systems as well as the mutual link-ups of production, organization and control units.

2.2.1. Enlarged span of control coefficient - r -

This coefficient expresses the ratio between the size of work organization units and control units in association with the ratio of complexity and demanding of managerial work of the managers in relation to their subordinates within these units.

2.2.2. Number of organization and control levels - n -

This number is a prerequisite for the necessity of the hierarchical arrangement of organizational structures within agricultural enterprises, resulting from the span of control of the managers, as well as from the necessity for organizational breaks of communication arrays in the managerial structures relative to the unpredictable behaviour of the managers.

The number of organizational and control levels can be derived from the following relation:

$$n = \frac{\log a_o - \log a_v - \log \rho}{\log q}$$

where:

- a_o – number of manual workers,
- a_v – number of workers at the highest level
- ρ – enlarged span of control coefficient
- q – span of control of the managers

2.2.3. Integrating factors

The integrating factor of agricultural enterprises' organization units creation is the qualification of managers. It represents their overall capability to perform the required activity resulting from the job position. The individual function positions within organization systems are represented by the complex of requirements and demands for the managers, as well as by their qualification prerequisites (Checkland 1981).

The qualification coefficient K simplifies the derivation of qualification of managers:

$$K = \frac{D_s}{D_n}$$

where:

- D_s – specialist preparation period that the worker completed, plus conversion of specialist experience period

D_n – specialist preparation period necessary for successful performance of the particular activity, complemented by the conversion of required specialist experience period

Should the qualification coefficient include even the influence of the specialist experience, it is necessary to convert it to the specialist preparation period. The usual ratio is 3–5 years of experience to 1 year of the specialist preparation.

Qualification coefficient may actually arrive at three basic values:

- a) $K = 1$, where the qualification dispositions correspond to the qualification requirements
- b) $K > 1$, where the qualification dispositions go beyond the qualification requirements
- c) $K < 1$, where the qualification dispositions do not reach the qualification requirements.

2.2.4. Qualification structure of the organizational system

Whilst dealing with the qualification of managers, it is possible to use additional auxiliary indicators – among which there belongs the management efficiency coefficient K_{me} as well as qualification structure of organization systems.

The management efficiency coefficient K_{me} enables comparison between managers of different age and various positions, without considering the specialist preparation period they went through. This coefficient presumes that at higher executive levels, it is necessary to have more managerial abilities than naturally developed with age, and they culminate at about the age of 50 (Heene, Sanchez 1997).

$$K_{me} = \frac{p \cdot (n - s)}{V_s - 20}$$

where: p – constant progression factor expressing the length of time required for the executive to remain at the individual functions long enough to get from the lowest level of management to the highest one.

$$p = \frac{V_p}{n}$$

where:

- V_p – productive activity age (about 40 years),
- n – number of management levels,
- s – the actually held position,
- V_s – real age

Qualification structure of organization system

This is expressed by comparing the structure of qualification dispositions of the managers (subjective qualification) to the structure of qualification requirements for the functional positions (objective qualification) characterized by a specific amount of necessary knowledge, skills and abilities.

3. 1. Principles of selecting an appropriate structure of organization and managerial structures

3.1.1. The appropriate basic type of organization structure can be estimated by judging the theoretical size (V_t) and the real size (V_s) of organization levels. In order to calculate the theoretical size, it is possible to use the parameters of management and organization capacity according to the relation:

$$V_t = a_v \cdot q_n \cdot r \cdot o$$

where :

- q – span of control normative of managers for particular conditions
- n – number of management levels
- r – enlarged span of control coefficient at the lowest management levels
- o – norm of organization capacity of manual workers
- a_v – number of managers at the highest management level

For a quick orientation it is possible to use:

- 1) if $V_t \leq V_s$, then the territorial type of organization structure is applicable,
- 2) if $V_t > V_s$, then it is appropriate to put in the branch type of organization structure.

3.1.2. The type of management structure can be derived from the assessment of the number of management levels, according to the average span of control of managers and from the requirements according to information loss within the control process.

- 1) If the real number of management levels (n) matches requirements according to the progress of information loss (m) so that:
 $n < m$
then the appropriate type is the functional type.
- 2) If the real number of management levels (n) does not correspond to the requirements according to the progress of information loss (m), which means that the number of management levels is too big so that an information bias within the control process occurs:
 $m < n$
then the appropriate type is divisional type.

3.1.3. The appropriateness of the individual types of complementary organization and control structures can be extracted also from the theoretical size of the basic organization level or an organization unit dealing with a specific activity, even including the technical capacity (v):

$$V_{iv} = s_v \cdot q_n \cdot o \cdot v \cdot \rho$$

The pivotal reasoning comes from the fact that the real size (V_s) of the basic level reaches values within the interval 0–2 V_{iv} and at further enlargement, there must originate a new organization unit and thus from the hierarchical point of view a further, higher organization level.

That is why the appropriate type of complementary structures can be derived from the following relations:

1. $V_s \leq 0.5 V_{rv}$ Coordination-cooperation type
2. $0.5 V_{rv} < V_s < V_{rv}$ Project-integration type
3. $V_{rv} < V_s < 1.5 V_{rv}$ Matrix-activity type
4. $1.5 V_{rv} < V_s < 2 V_{rv}$ Program-task type

3.1.4. Utilization of the factors and the model of behaviour within resource-based and target-based approach to management of a business

Within the resource-based approach the business strategy is implemented via a business plan, by securing new resources and parameters of the model (structural variable, company management variable and marketing

management variable) in order to create conditions for reaching the new – target – level of the resulting behaviour. Potential level of the target behaviour is attainable after a certain time period, when the current factor parameters will be eliminated and converted to the desired level.

The time delay can be gathered from the relation:

$$t = \frac{\log f_q - \log f_o}{\log [C(F + R)]}$$

Within the target-based approach from the given model, it is possible to trace the necessary level of the indi-

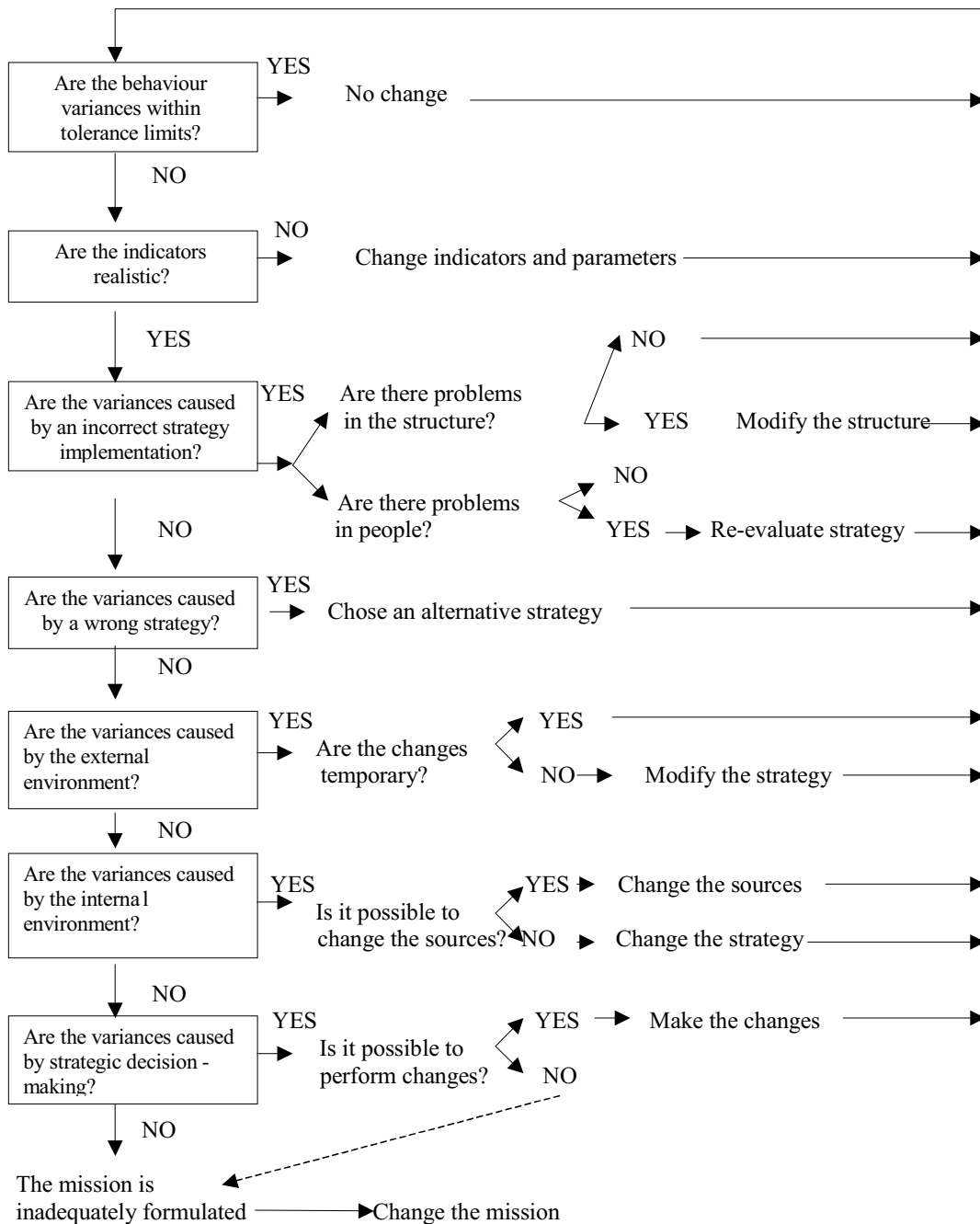

Figure 4. Evaluation of strategy and behaviour

vidual variables' parameters in order to reach the target level of resulting behaviour.

3. 2. Decision-making criteria for selecting purposeful types of organization and control structures

Suggestion of criteria of creating organization units is apparent from the characteristics of both internal and external factors and it expresses:

- A) Manageability of organization unit criterion with regard to span of control of the managers (q), enlarged span of control coefficient (ρ) and the number of organization and management levels (n).
- B) Production facilities of manual workers criterion, expressed by their organization capacity (o)
- C) Basic facilities of organization unit criterion in the means of technical capacity (v)
- D) Transformation (production) capacity criterion (s).

The introduced criteria may be used for the creation of the theoretical size of organization unit indicator (V_i), that can be expressed in correspondence with the criteria stated above:

ad A) by the number of manual workers

$$V_{iq} = a_v \cdot q^n \cdot \rho$$

ad B) by the number of hectares of agricultural land, cattle units and units of measure

$$V_{io} = a_v \cdot q^n \cdot \rho \cdot o$$

ad C) by the amount (value) of the means of production

$$V_{iv} = a_v \cdot q^n \cdot \rho \cdot v$$

ad D) by the amount (value) of production

$$V_{is} = a_v \cdot q^n \cdot \rho \cdot o \cdot s$$

These relations respect the resource-based approach.

C. Evaluating strategy and behaviour

The evaluation of strategy and behaviour itself can be expressed by the decision-making diagram resulting from a comparison of current and normative parameters, current and expected strategy (Figure 4).

D. Suggesting therapy

The therapy suggestion itself does not include only strategy formulation, but also the levels of parameters

and factors leading to the target behaviour. The implementation is, however, a complex process that respects personnel management principles, technological, technical, organization and control factors of development, and it creates a homeostatic relation to both the external and internal environment.

CONCLUSION

Homeostasis between a business and its internal and external environment is a reflection of its health. It is therefore necessary to monitor the organizational system and its individual parameters in each business, and to compare it to the desired behaviour and desired level. In this way, qualitative and quantitative analysis of its structure and behaviour can be used for the evaluation of strategy and for the proposal of solutions. The deciding factor in diagnosing a business's health and initiating therapy is the time factor and respect for procrastination, but above all it is the manager's and expert's qualification.

REFERENCES

- Band A.W. (1994): Touchstones (Ten New Ideas Revolutionizing Business). New York, John Wiley.
- Czerniawska F., Potter G. (1998): Business in a virtual world. London, MacMillan Press Ltd..
- Greiner R., Metes G. (1995): Going virtual. New Jersey, Prentice Hall.
- Hala R., Whitlam P. (1997): Towards the virtual organization. Boston, McGraw-Hill.
- Heene A., Sanchez R. (1997): Competence-based strategic management. New York, John Wiley.
- Hron J. a kol. (1996): Principy a mechanismy virtuálních organizací. Praha, ČZU PEF.
- Hron J. (1992): Struktura chování zemědělských podniků v podmínkách tržního hospodářství (Structure and behaviour of enterprises in market economy condition). Zemědělská ekonomika, 38 (4): 241–247.
- Checkland P. (1981): Systems thinking, systems practice. New York, John Wiley.
- Martin J. (1996): Cybercorp. American Management Association.
- Vodáček L., Vodáčková O. (1994): Management: Teorie a praxe 80. a 90. let. Praha, Management press.

Arrived on 12th October 2004

Contact address:

Prof. Ing. Jan Hron, DrSc. dr.h.c., Česká zemědělská univerzita v Praze, Kamýčká 129, 165 21 Praha 6-Suchdol, Česká republika
tel.: +420 224 384 081, fax: +420 234 381 855, e-mail: hron@pef.czu.cz
