

TR- 54  
1973



**Decision Analysis on Water Resources Planning and  
Management for an Arid Metropolitan Center in  
West Texas**

C.S. Shih  
J.H. Dean

---

**Texas Water Resources Institute**

---

**Texas A&M University**

RESEARCH PROJECT COMPLETION REPORT

Project Number B-102-TEX

(September 1, 1971--June 30, 1973)

Agreement Number

14-31-0001-3652

DECISION ANALYSIS ON WATER RESOURCES PLANNING AND  
MANAGEMENT FOR AN ARID METROPOLITAN CENTER IN  
WEST TEXAS

Principal Investigators

C. S. Shih and J. H. Dean

The work upon which this publication is based was supported in part by funds provided by the United States Department of the Interior, Office of Water Resources Research, as authorized under the Water Resources Research Act of 1964, P. L. 88-379.

Technical Report No. 54  
Texas Water Resources Institute  
Texas A&M University

October, 1973

## PREFACE

This report describes the research performed on OWRR Project B-102-TEX, sponsored by the United States Department of the Interior, Office of Water Resources Research, and the Texas Water Resources Institute, Texas A&M University.

The research reported herein describes the systems approach to decision making for urban water resources development for the metropolitan centers in Texas. A multiattribute decision analysis model has been developed and applied to current water resources development problems in both San Angelo and San Antonio, Texas. Important attributes considered in the selection of the optimum water resources development alternative include quantity, dependability, quality, cost flexibility, and socio-economic impact for each of the development alternatives.

The decision analysis solution to each of the water resources development decision problems will be presented in conjunction with the sensitivity analysis of the utility values obtained from decision makers in two Texas cities. The subjective judgements of different decision makers has been pooled for a consensus of opinion and integrated in the specific application of the general decision analysis model.

Decision analysis techniques and the theory underlying multiattribute utility functions has been discussed in detail. The art of problem decomposition and application of simulation techniques to sensitivity analysis has been demonstrated with two practice case studies. The implication of decision analysis will also be discussed.

#### IV

Many fine people in San Angelo and San Antonio deserve special thanks for the time and the information they have contributed. The individuals in San Angelo include: Tom Koederitz, Johnny Williams, Chic Conrad, Wiley Webb, Clark Erskine, Tom Adams, Fred Conn, Dick Howard, Kenneth Kruger, and J. W. West. The individuals in San Antonio include: C. Thomas Koch, Ed Harlee, Fred Pfeiffer, Robert Van Dyke, Carolyn Alexander, and Robert L. Frazer.

The administrative support generously given to us by the Texas Water Resources Institute, directed by Dr. J. R. Runkles, has been a great aid to our work.

The final completion of this project was done during the moving of both investigators. The convenience provided to C. S. Shih by the University of Texas at San Antonio must also be acknowledged.

## TABLE OF CONTENTS

CHAPTER		PAGE
1	INTRODUCTION . . . . .	1
	The Need for a Comprehensive Systems Approach to Urban Water Resources Planning . .	1
	Outline of the Research . . . . .	3
2	DECISION ANALYSIS. . . . .	6
	Bayes' Theorem. . . . .	7
	The Development of Decision Analysis. . . . .	9
	The Phases of Decision Analysis . . . . .	11
	An Illustrative Example . . . . .	12
3	UTILITY THEORY . . . . .	19
	Multiattribute Utility Functions. . . . .	24
	Keeney's Multiplicative Utility Theorem . . . . .	25
4	A SYSTEMS APPROACH TO URBAN WATER RESOURCES PLANNING. . . . .	32
	Selection of Attributes . . . . .	35
	Identification of Alternatives. . . . .	39
	Analysis of Alternatives. . . . .	45
	Selection of Optimum Actions. . . . .	49
	Sensitivity Analysis. . . . .	50
	A Perspective Look at Decision Analysis . . . . .	52
5	THE SUPPLEMENTARY WATER RESOURCE DEVELOPMENT PROBLEM OF SAN ANGELO, TEXAS . . . . .	54
	Physical Description of the San Angelo Area . . . . .	54
	Climate. . . . .	54
	Soils. . . . .	54
	Water Development. . . . .	56
	Community. . . . .	58
	Water Resources Environment . . . . .	59
	Meteorology. . . . .	59
	Hydrology. . . . .	60
	Water Quality. . . . .	61
	Water Resources Management Systems . . . . .	62

## TABLE OF CONTENTS (Continued)

CHAPTER	PAGE
5 (Continued)	
The Supplementary Water Resources Development Problem . . .	63
Attributes . . . . .	68
Sensitivity Analysis . . . . .	69
6 WATER-BASED RECREATION IN SAN ANTONIO, TEXAS . . . .	75
Physical Description of the San Antonio Area. . .	75
Climate. . . . .	75
Soils. . . . .	75
Water Resources Development. . . . .	76
Community. . . . .	77
Water Resources Environment . . . . .	78
Meteorology. . . . .	78
Hydrology. . . . .	78
Water Quality. . . . .	79
Management Systems . . . . .	81
The San Antonio River Walk. . . . .	83
The River Walk Expansion Decision Problem . . . .	85
Attributes . . . . .	86
Alternatives . . . . .	87
Sensitivity Analysis . . . . .	89
7 CONCLUSIONS AND RECOMMENDATIONS. . . . .	93
Discussion of Results . . . . .	93
Conclusions . . . . .	96
Recommendations . . . . .	97
REFERENCES . . . . .	98
APPENDIX	
I BAYES' THEOREM . . . . .	101
II KEENEY'S MULTIPLICATIVE UTILITY THEOREM. . . . .	103
III A SENSITIVITY ANALYSIS PROGRAM . . . . .	110

## LIST OF FIGURES

FIGURE		PAGE
2-1	Decision flow diagram. . . . .	14
2-2	Reversed chance node probabilities . . . . .	15
3-1	A risk averse utility curve. . . . .	22
3-2	Perspective on multiattribute utility theory . . . . .	28
4-1	Systems planning procedures. . . . .	33
4-2	A water resources development decision flow diagram. . . . .	40
5-1	State of Texas . . . . .	55
5-2	San Angelo water resources . . . . .	57
5-3	Final decision flow diagram for San Angelo . . . . .	70
5-4	CDF data . . . . .	71
5-5	Utility curves . . . . .	72
5-6	San Angelo utility distribution graphs . . . . .	74
6-1	San Antonio water resources. . . . .	80
6-2	Water-based recreation on the San Antonio River. . . . .	84
6-3	Decision flow diagram for San Antonio. . . . .	88
6-4	Utility Assessments and weights for San Antonio. . . . .	90
6-5	San Antonio utility distribution graphs. . . . .	91

## CHAPTER 1

### INTRODUCTION

The demand by consumers for public-owned low-priced natural resources is essentially insatiable. When natural resources become scarce the public is agonized by the problem of making an optimum choice or choices from feasible alternatives, preferably from a large number of feasible alternatives. In order to determine the best solutions in terms of satisfying constrained requirements, systematic procedures must be adopted for resources planning and management processes.

#### The Need for a Comprehensive Systems Approach to Urban Water Resources Planning

In the past, management and planning programs for water resources have been based primarily on one attribute--money. Sharp criticism has been directed to this type of single-minded planning approach as exemplified in the following speech by Senator Stephen Young, [38]

For a large segment of our water resources program, both the Executive Branch and Congress now scrutinize each project as though it were a narrow commercial undertaking. We concentrate attention on those direct prospective benefits which are strictly measurable in dollars and cents such as the dollar value of property saved from floods, or the amount by which river navigation saves freight charges. We then compare these narrowly construed monetary benefits to cost. In almost every instance, the benefits, human and social values, and vital objectives of national policy which cannot be measured in direct monetary terms often receive only supplementary attention, or none at all.



It has become the policy, as stated by Clayton, <sup>[11]</sup> of the National Water Commission, that water resource projects should not be evaluated merely on a pure benefit-cost ratio, but that intangible benefits should also be considered. This prevailing attitude has catalyzed the application of decision analysis embedded with multiattribute characteristics for water resources development decision-making procedures.

Decision analysis is a systematic solution procedure which can be used to crystalize a complicated decision problem into manageable subproblems by ranking the decision alternatives in accordance with cardinal values attached to their consequences based on the principles outlines in utility theory. Recent advances in multiattribute utility theory allow the decision maker to assess utilities over intangible benefits such as social acceptance or recreation potential. The relative importance of both intangible and tangible benefits such as cost or quality will all be weighted accordingly in the total utility evaluation. In this manner, the intangible benefits will receive due consideration in the final decision making process.

### Outline of the Research

The purpose of this project is to develop a comprehensive planning procedure to analyze the basic problems and evaluate feasible alternative solutions concerning water resources development for urban areas while giving due consideration to intangible attributes. Emphasis will be placed on the development and application of decision analysis to the solution phase of the urban water resources systems planning.

The planning procedure developed will encompass a total systems approach directed toward the attainment of more than sufficient water supply for an urban area. The systems approach is defined herein as the art of selecting a particular set of actions from a large number of feasible alternatives, constrained by legal, moral, economic, technological, political, social, etc., requirements to best accomplish the prescribed objectives of the decision maker.

The specific scopes of this project will include the following studies:

1. An overview of the state of the art of decision analysis and utility theory.
2. A realignment of the systems approach to urban water resources planning.
3. The development of a generalized decision analysis model for urban water resources development.
4. An application of the general decision analysis model for water resources development to two metropolitan

areas in Texas which possess unique social-economic characteristics.

5. Perform a sensitivity analysis on the subjective judgements used in the model.

Chapter 1 highlights the shortcomings of current decision-making procedures for water resources development as well as the appropriateness of using multiattributed consequences to compare decision alternatives. In addition, the outline of the research effort is summarized in Chapter 1.

The fundamentals of decision analysis are developed in Chapter 2. An example problem, for which the solution requires the use of Bayer's Theorem, will be structured and analyzed in detail.

Chapter 3 covers the theory of utility functions in quantifying consequences of decision alternatives. Emphasis will be placed on multiattribute utility functions.

In Chapter 4, a general systems approach to urban water resources planning will be described. Identification of planning attributes, or criteria, such as cost, quantity, quality, etc., will be discussed in conjunction with the overall goal of the planning problem. Selection of feasible alternatives and analysis of constraints will immediately precede the description of a general decision analysis model for urban water resources development. The solution procedures for the general decision analysis model will also be described.

Chapter 5 depicts the general water resources planning environment in San Angelo, Texas, followed by a description of the specific

decision problem concerning the supplementary water resources development. Also included is the decision analysis solution to the problem, along with a sensitivity analysis of subjective judgements used in the formulation of the analysis model.

Chapter 6 describes the water resources utilization problems of San Antonio, Texas, concerning water-based recreational development. The River Walk expansion decision problem is the specific problem chosen for application of the general decision analysis model. This specific problem will be solved and a sensitivity analysis will also be made, as in Chapter 5, on subjective judgements used in the problem formulation.

## CHAPTER 2

### DECISION ANALYSIS

Decision analysis, sometimes called Bayesian decision theory, is a systematic solution procedure which can be used to crystalize a complicated decision problem in such a way that the decision alternatives can be ranked in accordance with cardinal values attached to each alternative. The fundamental strategy in decision analysis is to break a large decision problem into smaller subproblems; make optimal decisions on these subproblems; then logically combine these subproblems to yield the best course of action for the original decision problem.

The basic elements of decision analysis may be described by decision flow diagrams in which the evaluations of judgmental or objective probabilities and multiattribute utility functions are included. The solution format consists of diagramming possible alternatives along with chance events that may or may not accompany an alternative; assigning probabilities to each chance event and evaluating the attributes for each alternative by applying multiattribute utility theory. This analysis yields an expectation or desirability for each alternative in a quantitative manner. A comparison of these values for various courses of action will enable the selection of the most favorable alternative. The choice of the decision maker will be well documented when using Bayesian decision theory and a sensitivity analysis, with respect to specific

subjective judgments used, may be performed to evaluate the reliability of the optimum choice.

### Bayes' Theorem

The origin of decision analysis is Bayes' Theorem, established by the Reverend Thomas Bayes and published in the *Philosophic Transaction of the Royal Society* in an article entitled "An Essay Toward Solving a Problem in the Doctrine of Chance" in 1763. In this article Bayes suggested that probability judgments based on mere hunches should be combined with probabilities based on relative frequency and he established a rather simple result using conditional probabilities. This theorem allows a decision maker not only to combine intuition with prior history but also allows him to reverse the chronology of events to evaluate probabilities of outcomes; if this reversal of chronological order would lessen the burden of probability assessment.

The usefulness of Bayes' Theorem is especially eminent when the decision maker feels that he is inadequately informed and yet he feels overwhelmed by magnitudes of information that he cannot use. This feeling is at least partially engendered from man's failure to fully utilize inconclusive but relevant information.

Consider a numerical example of this type problem. Suppose two indistinguishable urns containing either a predominant number of red or green balls is to be identified. Let urn 1 contain 7 red and 3 green balls and let urn 2 contain 3 red and 7 green balls. Suppose

you are allowed to sample 12 times from one of the urns, with replacement. Further suppose that the results of these samples are 8 red and 4 green balls. Initially the a priori probability of selecting a predominantly red or green urn was .5. Now in light of this vast additional inconclusive evidence, what is the post priori probability that the predominantly red urn was selected?

This problem resembles the plight of many decision makers. People tend to be very conservative when aggregating inconclusive evidence as in this type problem. Many people would estimate this post priori probability as being about .7 to .8. In actuality the probability that a predominantly red urn was selected is .97. This may be obtained by Bayes' Theorem in a straight forward manner. Bayes' Theorem may be stated as follows: If  $B_1, B_2, \dots, B_k$  are a set of mutually exclusive events of which one must occur and none has a zero probability, then for any event  $A$ , such that  $P(A) \neq 0$ , then

$$P(B_r|A) = \frac{P(B_r) \cdot P(A|B_r)}{\sum_{i=1}^k P(B_i) \cdot P(A|B_i)}, \quad r = 1, 2, \dots, k.$$

A proof of Bayes' Theorem may be found in Appendix 1. To solve the urn problem let  $B_r$  be the probability of a predominantly red urn and let  $A$  be the conditional event that 8 red and 4 green balls were sampled. Then the calculations resolve to

$$\frac{(.5)\binom{12}{8}(.7)^8(.3)^4}{(.5)\binom{12}{8}(.17)^8(.3)^4 + (.5)\binom{12}{8}(.3)^8(.17)^4} = .97.$$

This example illustrates the use of Bayes' Theorem and also the importance of being able to incorporate related but inconclusive information. Note that Bayes' Theorem permits the calculation of probabilities by going from effect to cause. This will be brought out clearly in the example of water development to be discussed later in this Chapter. It should also be noted that a philosophical controversy has been centered about Bayes' Theorem. Bayesians advocate the use of man's intuitive judgments in assisting with the determination of probability values, while non-Bayesians insist on using only objective or historical data to determine probabilities. But, in many cases, an application of man's reasoning to a problem is more practical than devising statistical experiments. In fact, many times it is impossible or too expensive to experiment.

#### The Development of Decision Analysis

Decision analysis emerged in the mid-1960's with its own identity in the field of management science. Perhaps the advantage of decision theory over other management techniques is the utilization of multiattribute utility theory. The foundation of utility theory was laid by von Neumann and Morgenstern<sup>[21]</sup> in their book, *Theory of Games and Economic Behavior*, published in 1945. The rise



in importance of decision analysis is largely due to recent advancements in utility theory by Fishburn<sup>[4]</sup> and Keeney.<sup>[17]</sup> Multiattribute utility theory allows one to quantify the seemingly important but generally neglected attributes of decision-making instead of minimization of costs or maximization of profits alone. Broad categories of important attributes such as institutional constraints and social desirability can now be integrated with cost or profits to construct a more comprehensive comparison base for different alternatives.

Raiffa, Schlaifer, Pratt, Drake, deNeufville and Keeney are largely responsible for the growth and enrichment of modern decision analysis and its applications. Pratt, Raiffa and Schlaifer<sup>[24]</sup> base an argument on basic behavioral assumptions that the decision maker should maximize expected utility based on subjective probability distributions. Schlaifer<sup>[28]</sup> applies decision analysis to practical problems that arise in the field of business administration. Raiffa<sup>[26]</sup> gives an indepth presentation of decision flow diagrams and probability assessments but makes light mention of multiattribute utility theory on which the future of decision analysis rests heavily. Keeney in his doctoral dissertation<sup>[16]</sup> and in a recent article<sup>[17]</sup> has adequately developed multiattribute utility to the point that utility theory incorporated with Bayesian decision theory is ripe for application in the area of water resources decision-making.

## The Phases of Decision Analysis

Most decision problems under uncertainty have two distinct characteristics:<sup>[31]</sup> (1) a choice or sequence of choices must be made among various courses of action or alternatives and (2) this choice or sequence of choices will ultimately lead to some consequence, but the decision maker cannot be sure in advance what the consequence will be because it depends not only on his decision but on an unpredictable event or sequence of events. The decision maker's choice of a course of action should depend on the likelihood that this course of action will result in various possible consequences and the desirability or undesirability (i.e., the preferences) for the various consequences. With decision analysis, these factors are formally incorporated into the analysis of the problem. Thus, we need to quantify the "likelihoods," which is done using judgmental probability, and quantify the "preferences," which is expressed with utilities. More will be said about these quantifications later.

The sequential phases in decision analysis are:

1. Structuring the Problem - Defining objectives and identification of feasible alternatives.
2. Assigning Probabilities to the Possible Consequences - Formally quantifying the decision maker's judgment.
3. Assigning Utilities to the Consequences for Each Alternative - Formal quantification of preference.

4. Calculative Procedures - Computing the best course of action by a procedure known generally as averaging-out-and-folding-back.

#### An Illustrative Example

In order to demonstrate the distinct phases of decision analysis consider herein a hypothetical water resources development problem. A small town must decide whether or not to develop a new ground water supply. If they choose to develop it, the quantity of water will be either "high" or "low." The objective of the town is to minimize costs of development. The town may make a geological survey costing \$5,000 to measure the quantity of water in the aquifer. Results of such a survey will be categorized as "great," "good" or "poor." If the quantity is "high," the benefit, not including geological survey costs is \$50,000. If the quantity is "low," there will be a cost of \$100,000 excluding geological survey costs. Note that the sale of surplus water may offset the cost if the quantity is "high." A cost of \$60,000 will be incurred if the alternative to ground water development is chosen.

The local water planners feel that the a priori probability of a "high" quantity of water in a nearby aquifer is .4. Given they knew a "high" quantity would result, the planners would assign a probability of .6 to the likelihood that the geological survey was "great," .3 to the likelihood it is "good" and .1 to the likelihood it is "poor." The corresponding probabilities given the quantity

would be "low" are .1 "high," .3 "great" and .6 "poor." What is the best strategy to follow in this problem? That is, should a geologic survey be conducted and should the town develop the ground water?

For ease of explanation, cost will be the only attribute considered important to the decision maker in this problem. Selecting the alternatives available to the decision makers and displaying them in what is known as a decision tree or a decision flow diagram is done in Figure 2-1. In decision flow diagrams, decision nodes are depicted by squares and chance nodes are indicated by circles. At the decision nodes the decision maker has complete control over the courses of action and at the chance nodes the decision maker has no control.

The chronology of events begins at the left and flows to the right. The first decision the decision maker must make is whether or not to make a geological survey. He determines the results of the survey before he decides whether or not to drill. He will learn the quantity of water in the aquifer after he drills.

The probabilities emanating from the chance nodes have been specified in the problem and they may be incorporated in Figure 2-1 after some calculations using Bayes' Theorem. Refer to Figure 2-2 for a pictorial display of the given probabilities. Some sample calculations applying Bayes' Theorem are:

DECISION FLOW DIAGRAM

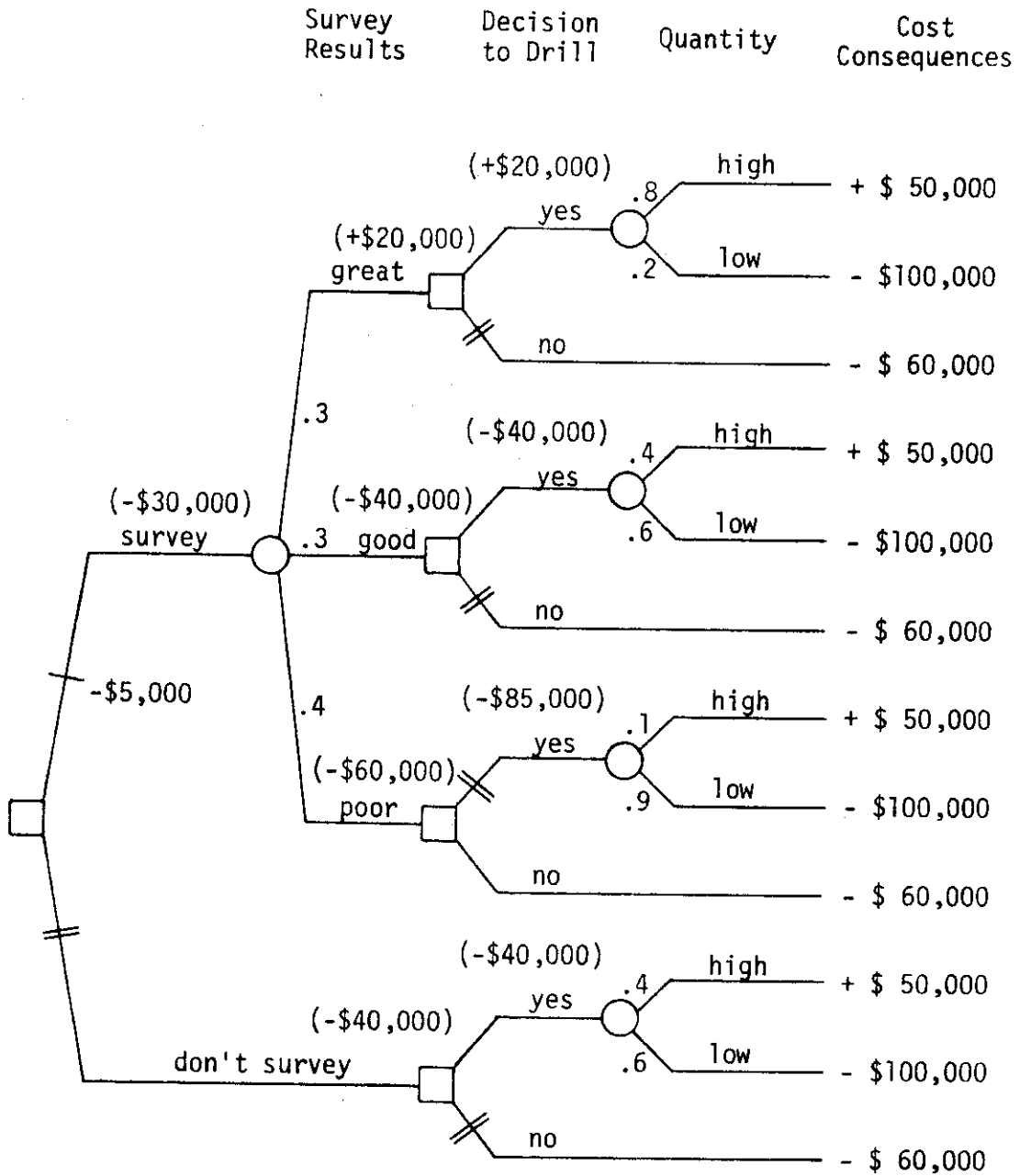

Fig. 2-1. Decision flow diagram.

## REVERSED CHANCE NODE PROBABILITIES

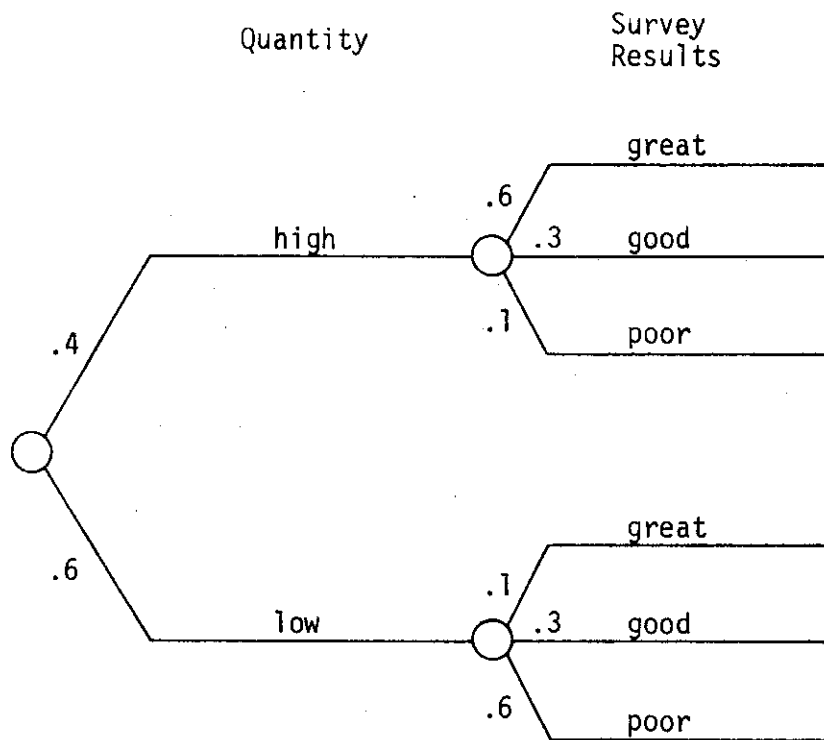

Fig. 2-2. Reversed chance node probabilities.

$$\text{prob}(\text{high quantity great in survey}) = \frac{(.4)(.6)}{(.4)(.6) + (.6)(.1)} = .8$$

$$\text{prob}(\text{high quantity good in survey}) = \frac{(.4)(.3)}{(.4)(.3) + (.6)(.3)} = .4$$

$$\text{prob}(\text{high quantity poor in survey}) = \frac{(.4)(.1)}{(.4)(.1) + (.6)(.6)} = .1.$$

By Lemma 1 of Appendix 1,

$$\text{prob}(\text{great in survey}) = (.4)(.16) + (.6)(.1) = .3$$

$$\text{prob}(\text{good in survey}) = (.4)(.3) + (.6)(.3) = .3$$

$$\text{prob}(\text{poor in survey}) = (.4)(.1) + (.6)(.6) = .4.$$

These calculated values may now be entered in Fig. 2-1.

The consequences of following a particular path through the tree is indicated at the end of that path. If quantity is "high" the consequence is a net benefit of \$50,000. If quantity is "low" the consequence is -\$100,000 and -\$60,000 would result from the decision not to drill.

To illustrate the general scheme of "averaging-out-and-folding-back" we will dispense with the additional complexity of scaling the consequences into utilities. Utility theory will be described comprehensively in Chapter 3. To begin the averaging-out-and-folding-back process, we work backwards chronologically on the decision flow diagram beginning with the first chance or decision node. In this problem we begin with a chance node. The expected

value at this first chance node is

$(.8)(\$50,000) + (.2)(-\$100,000) = -\$20,000$ . Similar calculations can be performed on the other chance nodes that may occur in the same time frame, i.e., the other chance nodes below the one just calculated. The expected costs determined can be thought of as replacing the chance nodes. The decisions of whether or not to drill can now be made by choosing the minimum expected cost among the branches stemming from the decision nodes. In the first decision of whether or not to drill a \$20,000 benefit is preferable to a \$60,000 cost. After these decisions have been made each decision node can be replaced by the minimum expected cost and the paths from each decision node that are not chosen may be eliminated by placing a double slash across each rejected path. This calculative and decision process is continued from right to left until the problem is solved. Note that the \$5,000 survey cost is displayed by placing a single slash across the path at which it occurs.

In this problem the result is that the decision maker can expect to incur a \$40,000 cost by foregoing the survey and a \$35,000 cost if he decides to survey. It is interesting to note that the survey can be worth at most \$10,000.

This water development problem has presented the fundamentals of decision analysis. Notice that subjective judgments were used in estimating the probabilities at each chance node. Some statisticians would say that these judgments are useless; others believe that an "educated guess" is better than no information at



all, especially when the "educated guess" is permitted to be updated as more information becomes available.

## CHAPTER 3

## UTILITY THEORY

In the above water development example, the consequences could be appropriately quantized in terms of dollars. The consequences could also have been quantized by a utility function, as utility concepts are adaptable to any type of consequence measurement. Utility theory, in many cases, may be the only method with which to quantize and to integrate attributes. If the attributes cannot be stated numerically, the "averaging-out-and-folding-back" technique will not be applicable; hence, decision analysis becomes an ineffective tool.

The axioms of utility theory were laid down by von Neumann and Morgenstern<sup>[21]</sup> as a set of rules for "rational" decision making.

Basically these axioms specify that a decision maker should

1. have a preference or be indifferent between two consequences,
2. prefer consequence  $a$  to consequence  $d$  if he prefers  $a$  to  $c$  and prefers  $c$  to  $d$ ,
3. be able to settle on a probability  $p$  such that he will be indifferent to  $b$  and some lottery with the probability  $p$  of receiving  $a$  and  $1 - p$  probability of receiving  $d$ , if he prefers  $a$  to  $b$  and  $b$  to  $d$ ,
4. not change his relative preferences for lotteries involving  $a$  when  $a$  is replaced by  $b$ , if he is

indifferent between  $a$  and  $b$ .

Axioms 1. and 2. are "weak order" axioms. They serve to establish the existence of ordering on the set of possible consequences. Axiom 3. establishes that this ordering can be expressed as a real-valued function. Axiom 4. is the substitutability axiom. The real-valued function over a set of consequences is called a utility function and the decision maker seeks to maximize this function. In decision problems where the decision maker feels that his preferences are compatible with these axioms of "rational choice," decision theory will become a very useful framework for analysis.

The utility function previously described is a cardinal utility function and can be used to measure relative preferences for uncertain consequences. Ordinal utility functions (also called value functions) measure relative preferences over consequences involving no uncertainty. Future references to utility functions will concern only cardinal utility function.

One useful property of utility functions implicit in the four axioms is that they are monotonic. That is, for the utility function  $u$ ,

$$u(x_1) \geq u(x_2)$$

if and only if consequence  $x_1$  is preferred or indifferent to consequence  $x_2$ . Decision makers may be characterized as being risk averse or risk prone according to their utility assessments.

The degree of risk proneness or risk aversiveness can be determined by assessing the decision maker's certainty equivalent for a fifty-fifty lottery. A decision maker's certainty equivalent for a lottery is the amount  $x_i$  for which the decision maker would be indifferent towards trading his lottery chances for. If a decision maker desired to retain his lottery for an amount  $x_i$  that is larger than the expected value of the lottery then the decision maker can be described as risk prone. If, on the other hand, he is willing to forego his lottery chances for an amount  $x_i$  that is less than the expected value of the lottery then his preferences could be described as risk averse.

Available techniques that are useful in measuring a decision maker's utility, or preference, over a set of consequences may be found in Pratt, Raiffa and Schlaifer<sup>[24]</sup> and Schlaifer.<sup>[29]</sup> Decision makers who have had experience in assessing certainty equivalents and probability values for lotteries may be able to give the decision analyst a rather precise utility function over a given attribute. However, if the decision maker is unfamiliar with these assessments it would be wise to request a minimum number of assessments. In the following example the important assessment points will be illustrated.

Assume that a decision analyst who constructed the previous water development example problem would like to assess the utility function of the town's mayor concerning the monetary consequences of the different outcomes. Refer to Fig. 3-1. The analyst might

## A RISK AVERSE UTILITY CURVE

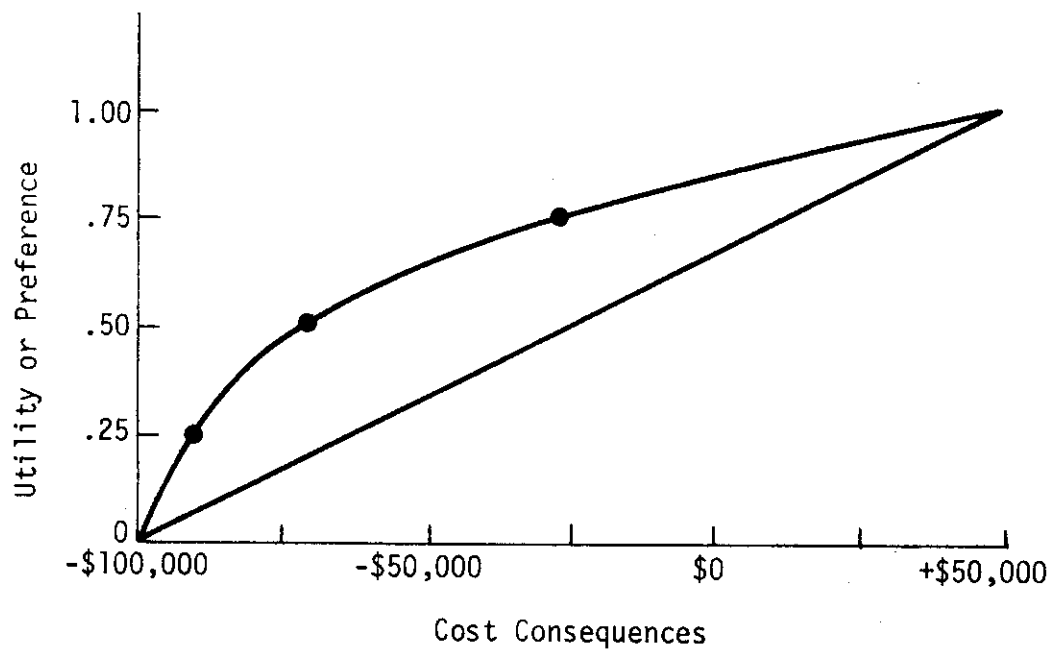

Fig. 3-1. A risk averse utility curve.

begin by explaining that two points on the preference curve have already been determined. The worst the decision maker could do would be to spend \$100,000 if he chose to drill. Hence a cost of -\$100,000 has a utility of 0. On the other hand the best the decision maker could expect is a benefit of \$50,000. Hence a benefit of \$50,000 has a utility of 1.0. Now the analyst might pose a lottery to the decision maker with equal chances of obtaining consequences of \$50,000 or -\$100,000 and ask the decision maker what his certainty equivalent for this lottery is. This lottery will be denoted by  $(1/2, \$50,000; -\$100,000)$ , where the probability value  $1/2$  in this case is associated with the first of the two consequences. When the certainty equivalent, say -\$70,000, is identified then the point  $(.5, -\$70,000)$  may be graphed. Next he could pose a  $(3/4, \$50,000; -\$100,000)$  lottery to the decision maker and settle on a certainty equivalent for this lottery. After establishing one more certainty equivalent for a  $(1/4, \$50,000; -\$100,000)$  lottery he will have five points as illustrated in Fig. 3-1. For rough calculation purposes these five points may be fit with a smooth curve. Once the decision maker is firm on his certainty equivalent estimations the decision analyst can use least squares<sup>[27]</sup> to fit a polynomial or an exponential function through the five points.

Once a curve has been constructed, utility values for the consequences may be read directly from a figure constructed such as Fig. 3-1 or calculated from the mathematical equation of the

curve. The water resources development problem may now be solved a little more precisely in terms of utility instead of dollars by substituting utilities in place of dollars as consequences and then averaging-out-and-folding-back the utility values.

### Multiattribute Utility Functions

There are various reasons why current decision studies, based on single-attribute utility functions such as in the ground water development example problem, result in solutions that politicians and local citizens hesitate to endorse. One prime reason is that, in many cases, the evaluation phase of these studies gives explicit treatment only to the costs. Intangibles such as quality and social response are treated either implicitly or not at all. In many instances the recommended solution is simply the alternative with the least direct cost to the community which oftentimes furnishes the minimum acceptable service. When using decision analysis this deficiency can be overcome by incorporating multi-attribute utility functions in the decision study.

Much research has been done on multiattribute utility functions. Fishburn<sup>[2,3]</sup> has derived necessary and sufficient conditions for multiattribute utility functions to be additive. His assumptions require that preferences depend solely upon the marginal utility functions and not on the joint utility functions. Pollack<sup>[23]</sup> has derived necessary and sufficient conditions for multiattribute utility functions to be additive or multiplicative; however, his

assumptions are arduous to verify because they concern utility independence conditions with several attributes varying simultaneously. In a recent article, Keeney<sup>[17]</sup> sets forth necessary and sufficient conditions for multiattribute utility functions to be either multiplicative or additive. The additive function is in fact a special case of the multiplicative function as will be seen later. The necessary and sufficient conditions required by Keeney are much easier to verify than the conditions imposed by previous research.

#### Keeney's Multiplicative Utility Theorem

Before stating Keeney's theorem on the necessary and sufficient conditions for a multiattribute utility function to be either additive or multiplicative, mathematical notation will be introduced and the definitions of preferential and utility independence will be given.

Let  $X \equiv X_1 \times X_2 \times \dots \times X_n$  be a consequence space, i.e., the result of a particular alternative path, where  $X_i$  is the  $i^{\text{th}}$  attribute and may be thought of as a scalar. A specific consequence will be designated by  $\underline{x}$  or  $(x_1, x_2, \dots, x_n)$ . The utility function over  $X$  of interest will be denoted by  $u(X_1, X_2, \dots, X_n)$  or simply  $u(\underline{X})$ . For convenience,  $X_{\overline{ij}}$  will be used in place of  $X_1 \times \dots \times X_{i-1} \times X_{i+1} \times \dots \times X_{j-1} \times X_{j+1} \times \dots \times X_n$  and  $x_{\overline{ij}}$  will be a member of  $X_{\overline{ij}}$ . Similarly, the notation  $X_{\overline{i}}$  will represent  $X_1 \times \dots \times X_{i-1} \times X_{i+1} \times \dots \times X_n$  and  $x_{\overline{i}}$  is a member of  $X_{\overline{i}}$ .



The assumptions used in Keeney's multiplicative utility theorem consist of both preferential independence and utility independence. Preferential independence occurs when one's preference for consequences  $(x_i, x_j, x_{\bar{i}\bar{j}})$ , with  $x_{\bar{i}\bar{j}}$  held fixed, does not depend on the fixed amount of  $x_{\bar{i}\bar{j}}$ . This implies that trade-offs between  $X_i$  and  $X_j$  do not depend on  $X_{\bar{i}\bar{j}}$ . Utility independence is present when one's preference over lotteries on  $X_i$ , written  $(x_i, x_{\bar{i}})$ , with  $X_{\bar{i}}$  held fixed is independent of the fixed amount of  $X_{\bar{i}}$ . An important mathematical property resulting from utility independence is that the conditional utility function over  $X_i$ , given  $X_{\bar{i}}$  is fixed at any value, will be a positive linear transformation of the conditional utility function over  $X_i$ , given  $X_{\bar{i}}$  is fixed at any other value. [17]

With this notation and these definitions in mind a fundamental theorem for multiattribute utility functions can be stated as follows.

Multiplicative Utility Theorem: Let  $X \equiv X_1 \times X_2 \times \dots \times X_n$ ,  $n \geq 3$ . if for some  $i$ ,  $X_i \times X_j$  is preferentially independent of  $X_{\bar{i}\bar{j}}$ ,  $j \neq i$ , and if  $X_i$  is utility independent of  $X_{\bar{i}}$ , then either

$$u(\underline{x}) = \sum_{r=1}^n k_r u_r(x_r) \quad (3-1)$$

or

$$1 + k u(\underline{x}) = \prod_{r=1}^n [1 + k k_r u_r(x_r)], \quad (3-2)$$

where  $u$  and  $u_r$  are utility functions scaled from zero to one,  $r = 1, 2, \dots, n$ , the  $k_r$  are scaling constants with  $0 < k_r < 1$ , and  $k$  is a scalar. Equation (3-1) is called the additive utility function and (3-2) is called the multiplicative utility function for rather obvious reasons.

An overall perspective of Keeney's theorem in conjunction with the definitions of utility and preferential independence is displayed in Fig. 3-2. The proof of the multiplicative utility theorem is long and arduous. The mathematically inclined reader can, however, find the proof in Appendix II.

In evaluating whether  $X_i \times X_j$  is preferentially independent of  $X_{\overline{ij}}$ , one could start by selecting values for  $x_i$  and  $x_j$  such that the decision maker is indifferent between the consequence  $(x_i', x_j', x_{\overline{ij}})$  and  $(x_i'', x_j'', x_{\overline{ij}})$  for some particular value of  $x_{\overline{ij}}$ . If this is possible then vary the value of attributes  $x_{\overline{ij}}$  throughout their ranges and see if the decision maker remains indifferent between the two consequences. If so, ask the decision maker if he is indifferent between  $(x_i, x_j, x_{\overline{ij}})$  and  $(x_i', x_j', x_{\overline{ij}})$  for any  $x_{\overline{ij}}$ . If the answer is affirmative then the preferential independence of  $X_i \times X_j$  and  $X_{\overline{ij}}$  has been established. Now the decision analyst must check the other  $X_j$ ,  $j \neq i$ , for preferential independence of  $X_i \times X_j$  and  $X_{\overline{ij}}$ .

To check for utility independence, certainty equivalents may be used. Utility independence is present when the certainty equivalent  $(x_i, x_{\overline{ij}})$  is indifferent to a lottery yielding  $(x_i', x_{\overline{ij}})$

PERSPECTIVE ON MULTIATTRIBUTE UTILITY THEORY

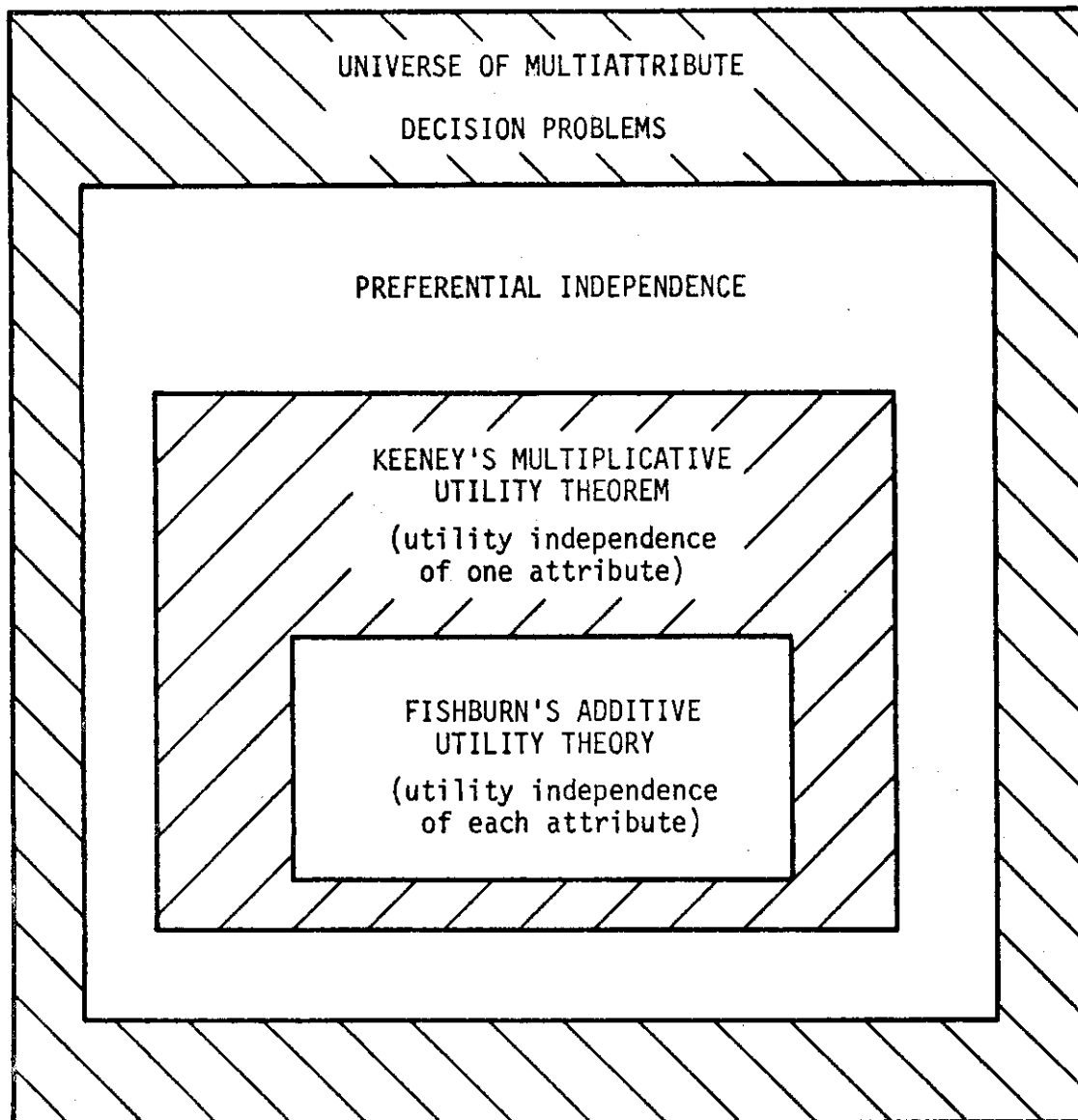

Fig. 3-2. Perspective on multiattribute utility theory.

and  $(x_i'', x_{-i})$  for all values of  $x_{-i}$ . In practice, if such a condition holds for three or four fifty-fifty lotteries covering the range of  $x_i$  for approximately four different values of  $x_{-i}$  covering the range of  $x_{-i}$ , then it is justifiable to assume that utility independence exists. [17] A cross-check of utility independence involves assessing conditional utility functions over  $x_i$  given different amounts of  $x_{-i}$ . If  $x_i$  is utility independent of  $x_{-i}$  then the following linear transformation

$$u(x_i, x_{-i}^+) = u(x_i^+, x_{-i}^+) + b(x_i^+, x_{-i}^+) u(x_i, x_{-i}^-)$$

will be present.

In order to assess the scaling constants  $k_i$  the decision maker selects a probability  $P_i$  such that he is indifferent between  $(x_i^*, x_{-i}^0)$  for certain and a lottery yielding either  $\underline{x}^*$  with probability  $p_i$  or  $\underline{x}^0$  with the probability  $(1 - p_i)$  where  $\underline{x}^*$  is the most preferred and  $\underline{x}^0$  is the least preferred consequence. In lieu of having the decision maker choose the probability  $p_i$  outright, it may be wise for the decision analyst to select  $p_i$  and then adjust this value in accordance with whether the decision maker prefers  $(x_i^*, x_{-i}^0)$  or the lottery until  $(x_i^*, x_{-i}^0)$  becomes the certainty equivalent for the lottery.

Since

$$u(x^*) = u(x_1^*, x_2^*, \dots, x_n^*) = 1$$

and

$$u(\underline{x}^o) = u(x_1^o, x_2^o, \dots, x_n^o) = 0,$$

the expected value of the lottery is

$$p_i u(x^*) + (1 - p_i) u(\underline{x}^o) = p_i$$

and since  $(x_i^*, x_i^o)$  is the certainty equivalent for the lottery

$$u(x_i^*, x_i^o) = p_i.$$

By evaluating (3-1) or (3-2),

$$u(x_i^*, x_i^o) = u(x_1^o, \dots, x_{i-1}^o, x_i^*, x_{i+1}^o, \dots, x_n^o) = k_i$$

since

$$u_i(x_i^o) = 0$$

and

$$u_i(x_i^*) = 1.$$

Hence the lottery probability is the scaling constant,

$$u(x_i^*, x_i^o) = k_i = p_i.$$

The evaluation of the multiplicative scaling constant  $k$  may be done in a number of ways. Equation (3-2) may be simplified by letting  $\underline{x} = \underline{x}^*$  so that

$$1 + k = \prod_{i=1}^n (1 + k k_i).$$

The values of  $k_i$  may be inserted before or after the implied multiplication is carried out to yield an  $n^{\text{th}}$  order polynomial in which  $k$  is the only unknown. Many existing numerical techniques may be used, such as Newton-Raphson,<sup>[27]</sup> to solve for  $k$ .

## CHAPTER 4

## A SYSTEMS APPROACH TO URBAN WATER RESOURCES PLANNING

The available water resources for an urban area is recognized as a dominant factor in its future economic growth.<sup>[30]</sup> The total water requirement for an urban area generally increases exponentially with population while the consumptive use of water is normally only a small fraction of this total requirement. A reasonable estimate of household water consumption in North America is about 50 gpd per capita.<sup>[18]</sup> This figure is small in comparison with total domestic water uses in fire-fighting, street cleaning, public buildings, small manufacturing and irrigation. Cities which publicly adopt a "philosophy of plenty" attitude toward water resources and back up this attitude with political action tend to attract substantial private investment. Cities which prefer to ration water rather than develop new supplies are likely to attract suboptimal levels of investment. Some urban areas may prefer a water resources planning program which is somewhere between these two attitudes.

A general procedure for an overall water resources planning program is shown schematically in Fig. 4-1. To effectively cope with identified water resources development problems, different coordinated engineering alternatives and resource development investigations must be initiated with the cooperation of various state, federal and private institutions. These total efforts must

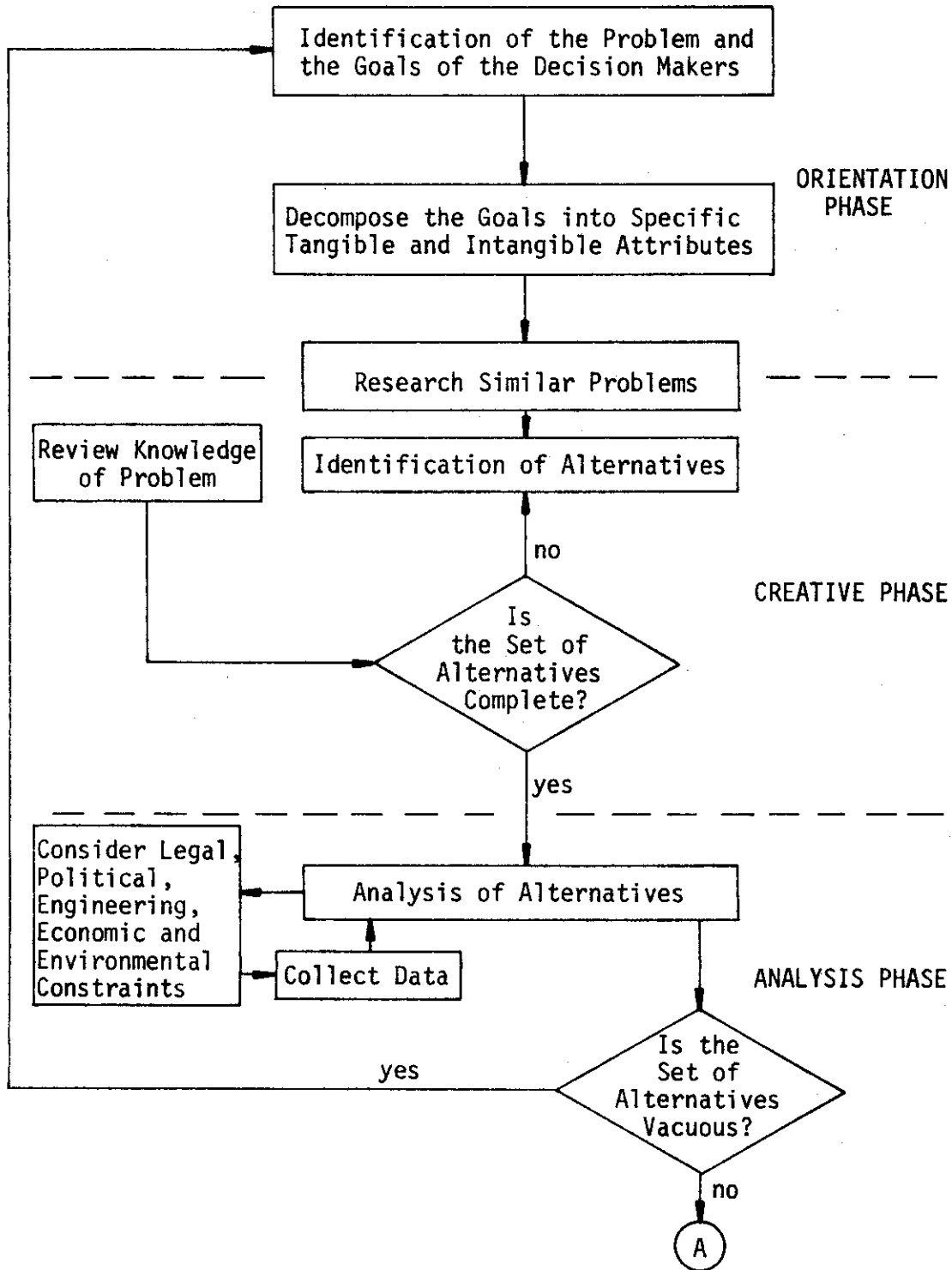

Fig. 4-1. Systems planning procedures.



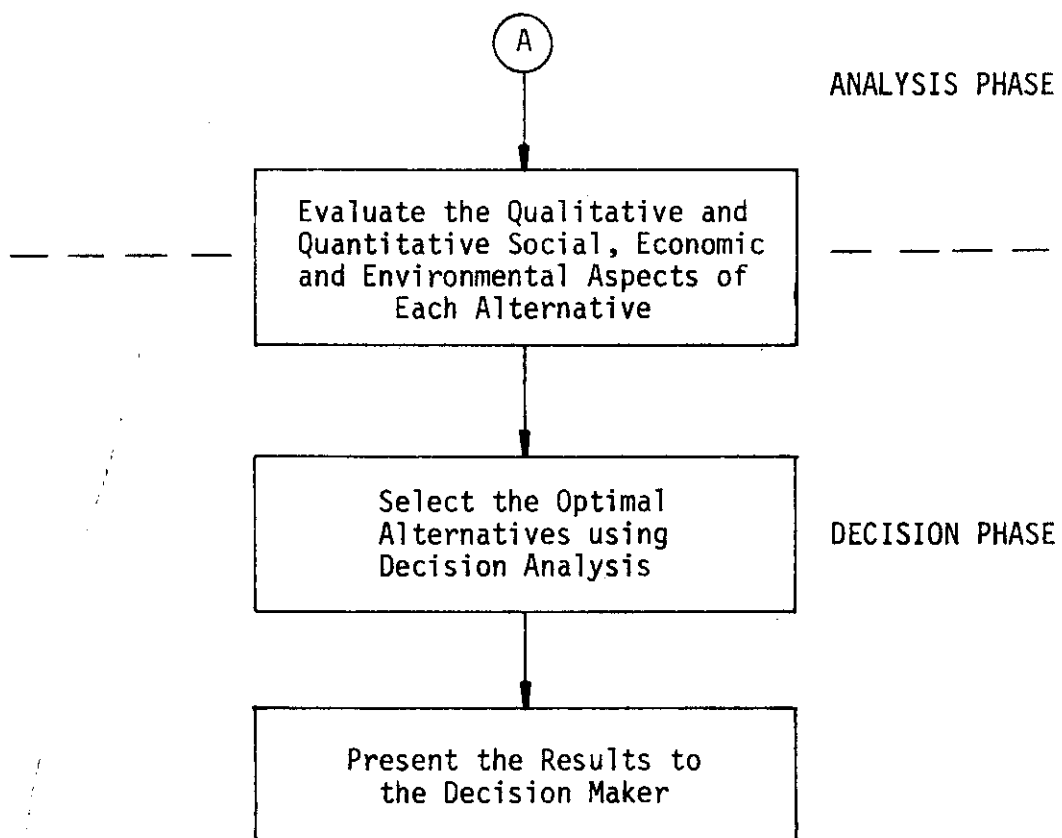

Fig. 4-1. (Continued).

be integrated under an unbiased systems approach satisfying the requirements of flexibility, implementability and operability of the dynamic nature of water resources planning and management. The different phases of the general planning procedures identified in Fig. 4-1 are discussed herein.

### Selection of Attributes

In the "orientation phase" of planning, the decision maker must specify a clear and detailed identification of the general decision problem. The problem should be succinctly stated in terms of the goals of the decision maker. After identification, the goals may be broken into specific attributes which can be quantified with utility assessments of the decision maker. Attributes should not be limited solely to tangible quantities such as cost or quantity. Attributes should also include intangibles such as public acceptance, social-economic impact, dependability, practicality, adaptability, flexibility, etc., since utility theory applies equally well to intangible attributes as to tangible attributes.

It seems reasonable to adopt, in the beginning, the general goals for water resources systems development formulated by Hall and Dracup.<sup>[13]</sup> These three goals are:

1. To control the freshwater resources of the city so as to provide for protection against injurious consequences of excesses or deficiencies in quantity or quality.
2. To maintain water in such places and times so as to

provide adequate quantity and quality for human consumption, food production, food processing, industrial production, commercial needs, recreation, ascetic and conservation purposes considered desirable by local policy.

3. To accomplish both 1 and 2 with a minimum expenditure of physical, economic and human resources.

Societal effects must be included in the goal-seeking statement since these effects have been highlighted as the primary concern of technological development in this decade.<sup>[20]</sup> Thus, a fourth goal should be included as

4. To enhance the quality of life and to improve the social environment in urban areas.

These goals for water resources development may be broken into five independent attribute categories. These categories include: quantity, dependability, quality, cost, flexibility, and social-economic impact.

The quantity of water provided by an alternative is certainly an important attribute to be accounted for in the evaluation of alternatives. A convenient measure of quantity is in acre-feet per year.

Dependability is related to quantity in short-term planning periods but not necessarily related in long-term planning periods. A surface water reservoir, for example, may have a lower utility value for dependability than a ground water reservoir with the same

quantity of water in storage due to evaporation conditions.

The quality and cost of alternatives are fairly explicit attributes. In the general decision analysis model, cost will be considered in dollars per year and quality will be spoken of in terms of total dissolved solids (TDS) in mg/l. Irrigational, industrial, recreational, etc., revenue may logically be deducted from cost.

Flexibility is intended to be a measure of the responsiveness of a water resources alternative to meeting changes in demand. These changes can be drastic, since the demand varies exponentially with population as well as climate or seasonal conditions.

Social-economic impact is intended to cover a variety of similar considerations such as public acceptance, recreation, environmental effects, urban enhancement, flood control, economic stability and economic growth. Social acceptance may be thought of in terms of voter's attitudes. The utility for public acceptance can be obtained by asking the decision makers to assess the chances for passage or the relative popularity of a bond issue to raise money for each alternative. Recreation may be defined as the aesthetic feelings of serenity and leisure plus the physical recreation activities such as boating, fishing and swimming. Environmental effects may include the enhancement or degradation of nature. Conservation of natural resource advocates say that natural conditions should be disturbed as little as possible. The damaging environmental effects of mining a ground water aquifer, for instance,

may be an important consideration of the decision makers. Urban enhancement includes the increased attractiveness of the city due to the water resources development alternative chosen. Flood control benefits may be easily inflated to justify almost any reservoir construction project. The reclaimed land yielded by flood protection may stimulate building on flood plains which in the long run may have disastrous effects when a 50 or 100 year flood occurs. Economic growth and economic stability can only be enhanced by insurance against drought or flood conditions. The degree of growth and stability generated by a water resource development alternative is of course dependent on how critical water shortages are projected for the future.

If the weight attached to social-economic impact is relatively high in comparison to weights of the other attributes, it may be broken into the seven considerations as specified above. In this manner the importance of the overall social-economic attribute may be described less ambiguously so that it can be more accurately assessed with utility theory.

When the identification of attributes important to the decision makers is apparently complete it would be wise to research similar problems to make sure that all attributes pertaining to the particular decision problem have been considered. While researching similar problems the decision analyst should be conscious of the identification of alternatives for the alleviation of the decision problem.

### Identification of Alternatives

In the "Creative Phase" of systems planning, alternatives for the alleviation of the decision problem are identified. Common water resource development alternatives for the alleviation of urban water shortage in the Southwestern United States include (but are not limited to): rivers and streams, ground water development, reservoir addition, waste-water reclamation, cloud seeding, dual supply systems, desalination, water importation, urban runoff utilization and managerial adjustments such as rationing.

Figure 4-2 is a plausible decision flow diagram for the common water resource development alternatives. Discussions of these water resource development alternatives follow.

In areas with humid climates and ample surface runoff, municipal water supplies may be entirely obtained from surface waterways. However, in arid climates most of the water comes from ground water sources. Two factors that determine the appropriateness of using surface waterways are quality and quantity of streamflow. In the absence of storage capabilities the dependable quantity of water obtainable from surface waterways can be at most as high as the lowest recorded flow of the waterway. Characterizations of a waterway needed to determine its dependability include such variables as climate, soils, water rights, and the size of the drainage basin. Obviously a wet climate and a large drainage basin tend to produce a large dependable flow. Not so obvious is the fact that impervious

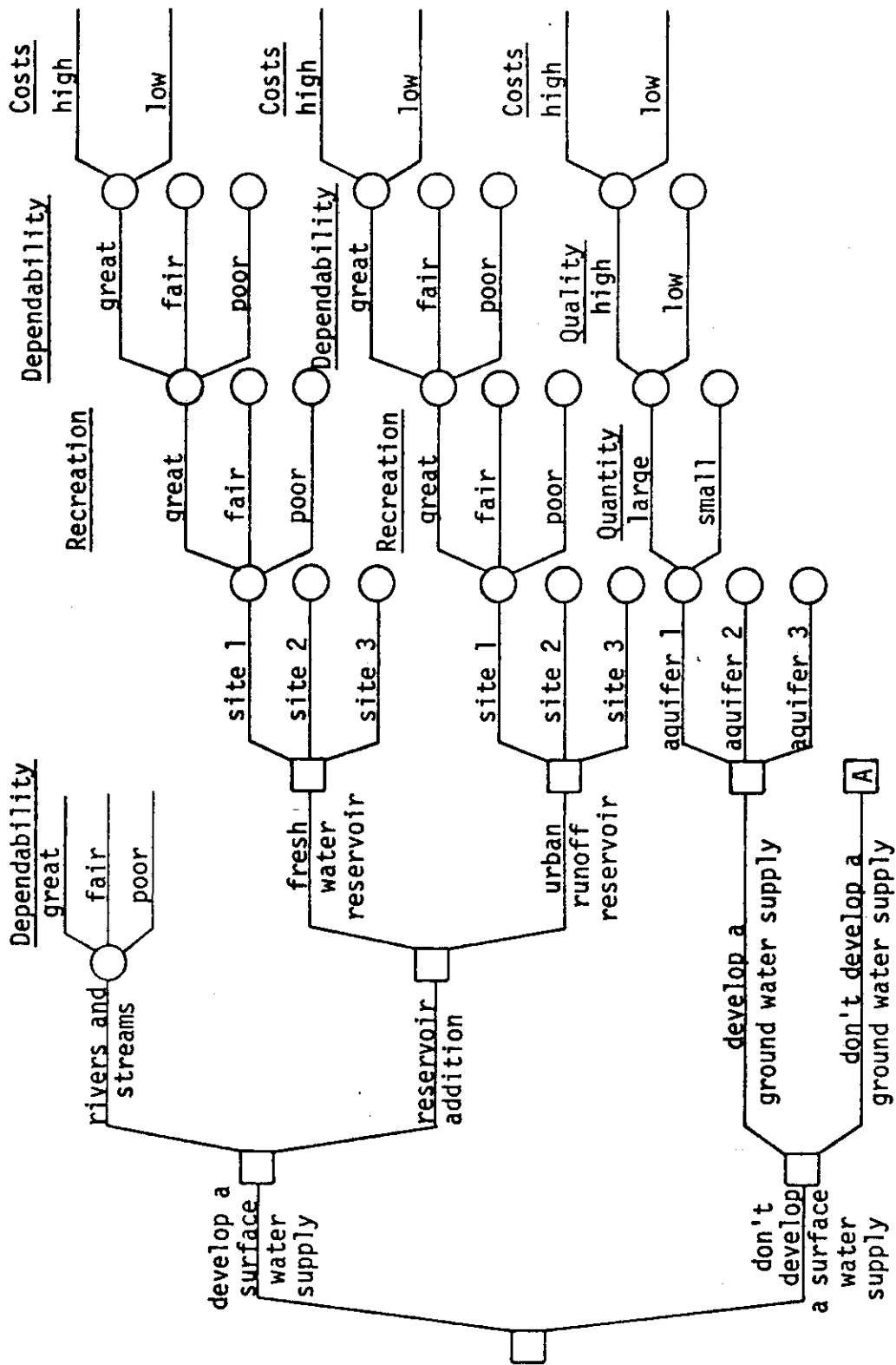

Fig. 4-2. A water resources development decision flow diagram.

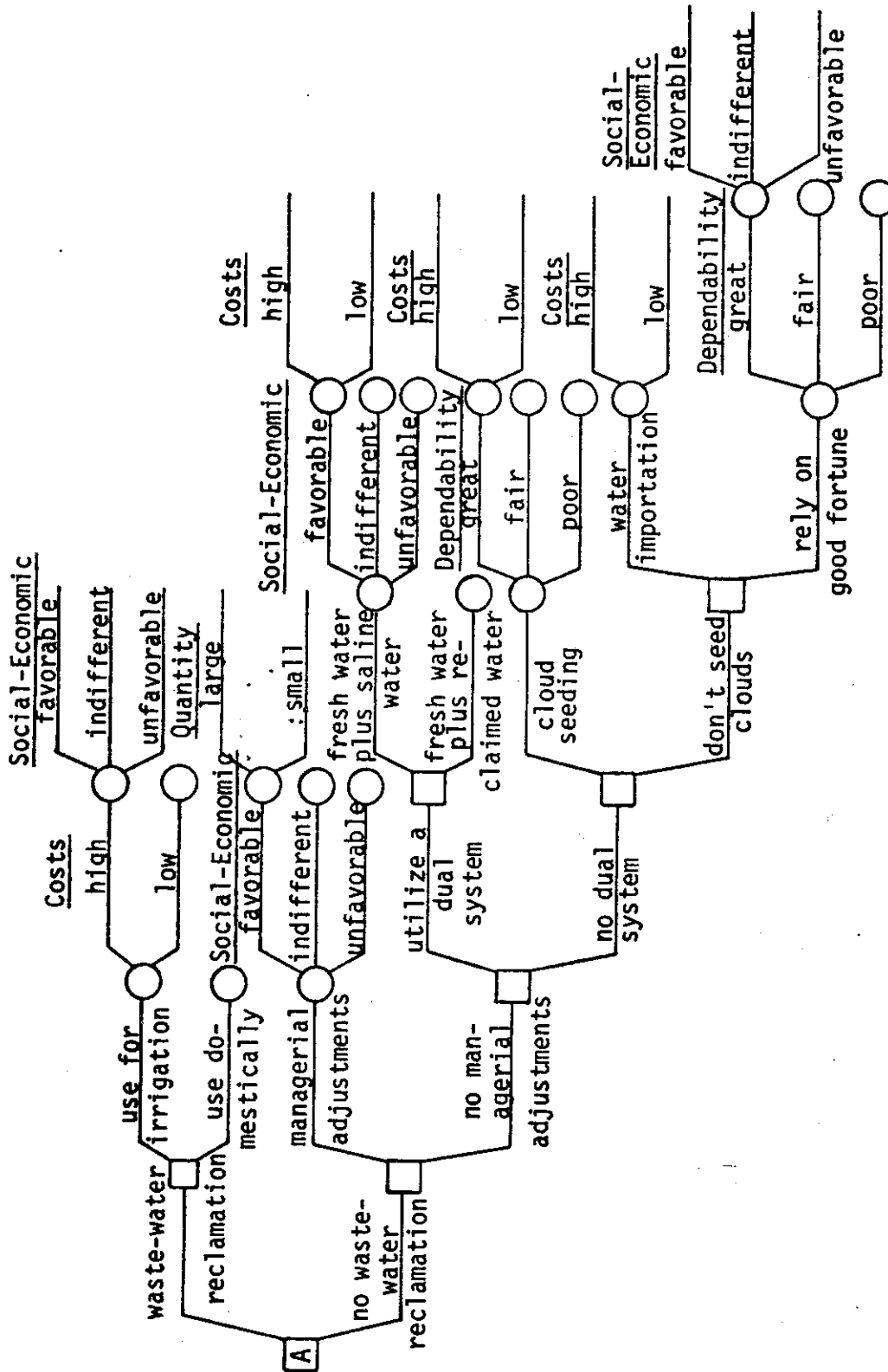

Fig. 4-2. (Continued).



soils such as shales have runoff characteristics similar to impulse functions while porous soils such as sand and gravel tend to soak up water like a sponge and release it very slowly, thus creating very dependable flows.

Ground water reservoirs (i.e., aquifers) may have a storage capacity several hundred times greater than the average annual precipitation that falls on the aquifer's recharge zone. The quantity of water stored will probably rise slowly during wet years and fall slowly during drought years. This ground water hydrologic cycle tends to smooth out rainfall fluctuations. When this hydrologic cycle is tampered with, such as when wells are dug, the quantity of water in the aquifer will, of course, be diminished. In some cases this may be of no consequence such as when the natural recharge of the aquifer is more than the pumpage. On the other hand, heavy pumping of ground water reservoirs may deplete the ground water resources. In coastal areas the water table may be lowered to such a level that allows salt water intrusion.

Legislation for the control of ground water is largely lacking, as will be mentioned in more detail in the next section. People desiring to develop ground water resources may impose hardships on existing users. Since the natural discharge of ground water aquifers often flows into streams and creeks, irrigation by farmers with water taken from these streams and creeks is an indirect use of groundwater that may be impossible if the water table is lowered. This decrease of streamflow is extremely difficult to measure since it may take

several years before a new equilibrium is established. Thus, comprehensive studies of ground water aquifers must be made before any pumpage is planned. Currently, the maximum pumpage is limited by the safe yield or the minimum recharge rate.

When the dependable flow of a watershed is inadequate but the average flow is sufficient to satisfy demand, a reservoir is appropriate for satisfying urban demands. A side benefit of reservoirs is their tendency to enhance the quality of water stored due to the fact that suspended sediment will settle out of the water. In addition, water-based recreation may also be developed.

At the present time waste-water recycling is technologically possible but prohibited for household use by social constraints. Different degrees of treatment can be applied to waste-water to produce different qualities of effluent. In many cases, quality standards imposed by governing agencies are flexible enough that a second and third reuse of water will be possible before the reclamation cost becomes prohibitive.

Cloud seeding technology is still in the infancy stage. Artificial nucleation of clouds is, however, widely used today even with the uncertain results. There is evidence that cloud seeding may slightly modify the precipitation pattern over a wide area downwind but this modification doesn't appear to be significant enough to produce a change in the climate. Estimates of localized increases in precipitation range from 5-15%.<sup>[22]</sup> Since artificial nucleation has the possibility of increasing precipitation for

specific areas, it might be applied to a watershed for the benefits of reservoir replenishment, desired runoff generation and farm irrigation.

Cities usually have a single network of pipes for their municipal water supply. When a shortage of fresh water is experienced, recycled or desalinated water could be used in a dual capacity. This is possible because many water usages such as lawn sprinkling, street cleaning and car washing do not necessarily need high-quality water. Public health officials are strongly critical of this alternative because of the danger of cross connections of pipes with a resulting danger to public health. Dual supply systems are also extremely expensive to install in fully developed urban areas. This expense could be minimized, however, by initiating dual systems in areas still in the early development stages.

The alternative which has captured the imagination of the general public is conversion of large quantities of sea water or brackish ground water into freshwater at a nominal cost. Desalination was long ago realized to be a very economical alternative for certain purposes such as boiler-feed water and for a potable water supply aboard ships. These conversion systems are low in cost with respect to other alternatives in those circumstances but are high when compared with existing surface or ground water development. Although the cost of desalination is still prohibitively high by current economic scales, it is becoming competitive economically even for municipal and industrial applications due to the soaring

cost of labor, increasing water demand and the economic scale of nuclear energy.

Less favorable alternatives include water importation, urban runoff utilization, managerial adjustments and continuation of current policy. Water importation for urban areas is extremely infeasible due to the quantity of water that would have to be imported. Capture and utilization of urban runoff yields water of very poor quality. Managerial adjustments such as rationing and rate-adjustment are very unfavorable in terms of political consequences. One obvious alternative is to continue the current water policy, whatever it may be, and depend on good fortune for future water resources security.

In cases where individual alternatives mentioned above do not have an expected quantity sufficient to meet projected or current needs, it is possible to combine two or more of these smaller alternatives in order that another alternative with sufficient expected quantity may be created.

When the decision makers and the decision analyst are satisfied that an exhaustive set of alternatives have been identified, the analysis of alternatives begins.

### Analysis of Alternatives

The "Analysis Phase" of general planning procedures consists of data collection and considerations of legal, political, engineering, economic and environmental constraints.

Data collection includes basic information such as hydrological, meteorological and water quality parameters. The data can be collected in terms of specific parameters or variables in order to facilitate the analysis of water quantity and quality effects and interactions. Historical or probabilistic trends must be defined and models relating variables and effects must be formulated.

Constraints of the type listed above may eliminate alternatives from further consideration. Legal constraints may include right-of-way, easements, water rights and water quality standards. Political constraints may be issued from local, regional and higher level governmental authorities and may take the form of policy constraints which include a priori judgments. For example, a local policy constraint may prohibit waste-water recycling. It is felt that legal and political constraints deserve special attention due to their intransigence with respect to effective water resources planning; whereas the nature of engineering, monetary and environmental constraints is rather apparent. The salient characteristics of legal and political constraints observed in Texas are described herein.

Early Anglo Saxons in this country brought with them the English concept of riparian rights whereby people who owned property along streams had a relatively unrestricted privilege to use of the stream water. This policy did not work well even in wet country. And in dry areas, especially where the enormously consumptive use of water for irrigation is encountered, it has worked so

miserably that feuds have been a common outgrowth of this policy. Therefore, years ago, water laws began to include what is called the doctrine of prior appropriation. Under the doctrine of prior appropriation the individual that first uses the stream water has a favored legal claim on continued use of it. Anyone who arrives late to make his claim is essentially out of luck. These two doctrines exist side by side in Texas law. Prior appropriation is generally applied. Prior appropriations grants preference to certain types of users; namely, towns receive preference over farmers. At present riparian right is essentially interpreted as being applicable to domestic and livestock needs of stream-side owners. No rationality at all has managed to worm itself into the governance of ground water as pointed out by Boyle.<sup>[1]</sup> Medieval misconceptions about the hydrologic cycle have continued to rule up to now even when practically all of the nation's aquifers have been studied to the point that scientists have a good idea of their capacities, extent, transmissions, recharge characteristics and reliability such that a "sustained yield" can be determined. Yet laws of many states, including Texas, continue to regard ground water as a mysterious blessing unrelated to other water and legitimately subject to capture and use in unlimited quantities by any property owner who has a well.

The other problem facing municipal areas is coordination of a multitude of agencies exercising control over water resources. Creation of a Water Resources Management System would alleviate

overlapping authority and responsibility for the coordinated management of urban water resources. As an example of the duplicity that can evolve in control of water resources consider the case of San Angelo and San Antonio, Texas, two cities in which many different governing agencies exercise control over water resources. Federal agencies exercising control in both cities include the following: Environmental Protection Agency, Water Resources Council, Bureau of Reclamation, U.S. Geological Survey, Public Health Survey, Council on Environmental Quality and U.S. Army Corps of Engineers. State agencies exercising control in both cities include the following: Water Control and Improvement District, Texas Water Development Board, Texas Water Rights Commission, Texas Water Quality Board and Texas Parks and Wildlife. Local and regional agencies in San Angelo include the City of San Angelo, Concho Valley Council of Governments, Colorado River Municipal District and Colorado River Authority. Local and regional agencies in San Antonio include the City of San Antonio, Bexar Metropolitan Water District, Bexar County, San Antonio River Walk Commission, Edwards Underground Water District, San Antonio River Authority and Alamo Area Council of Governments. This labyrinth of control in both cities obviously makes the execution of proper planning quite difficult.

Water resource development alternatives which meet the constrained requirements described above should be evaluated in further detail. Evaluations on the data collected may include engineering design techniques, economic evaluation techniques, projection and

forecasting techniques, mathematical modeling, simulation, optimization mathematical programming and stochastic programming. Before the "Decision Phase" is initiated the decision makers should be thoroughly informed of the qualitative and quantitative impacts of each alternative in regard to social, economic and environmental concerns.

#### Selection of Optimum Actions

The "Decision Phase" of systems planning procedures combines the techniques of decision analysis with multiattribute utility theory. The fundamental procedure for obtaining the decision analysis solution from among the feasible decision alternatives involves selecting an attribute and making utility assessments for each feasible alternative. This procedure is duplicated for each attribute. It is important for the minimum and maximum utility values for each attribute to be 0. and 1., respectively, and the other utility assessments are relative to this 0. to 1. scale.

After the completion of utility assessments, weights, or scaling constants as explained in Chapter 3, are assigned to each attribute.

If the sum of the weights for the attributes is 1. then the additive utility function, Equation (3-1), is employed in computing the utility of each alternative. If the sum of the weights is other than 1. then the multiplicative utility function, Equation (3-2), will be used to calculate the utility of each



alternative. The alternative with the highest utility value is the most preferred choice of the decision makers.

If the utility values for a few alternatives were clustered as the most preferred choices, then the decision analysis procedures could be repeated with just these clustered alternatives in consideration. The 0. to 1. utility scaling of the least and most preferred alternative for each attribute would then take on increased importance in breaking out the cluster of alternatives.

#### Sensitivity Analysis

An extra calculative procedure, appropriately termed as a "sensitivity analysis," that enriches this type of subjective decision-making involves computer simulation of the utilities assessed. The data necessary for a sensitivity analysis is collected at the same time the decision makers are specifying utilities for the individual attributes. Instead, or in addition, to asking the decision maker to state a specific utility number, allow him to give a range of numbers. For instance, instead of specifying that the utility of alternative two for the third attribute is .6, allow the decision makers to give a range of say .55-.65. This procedure is readily accepted by decision makers since it allows them some latitude in their subjective judgments.

When ranges of utility values and weights have been collected, the utility of each alternative may be computed in a manner analogous to the one mentioned before. The only difference is that, in this

latter case, random numbers are generated in the ranges of utility assessments. The specific utilities are thus the random numbers within the specified intervals. The decision process can be simulated hundreds or thousands of times using random numbers. When a frequency distribution for each alternative is graphed in terms of utility versus frequency of occurrence, the decision makers can discern the relative sensitivity of each alternative by comparing the widths of each distribution. Thus, if the most preferred alternatives are clustered, a sensitivity analysis might be an aid by which the decision makers could select the most preferred alternative.

Another advantage of performing a sensitivity analysis is that it tends to smooth out slight errors in subjective assessments made by the decision makers. Random number simulation tends to lessen the compounding effects of these small judgmental errors in this type of a problem.

The utility assessments procedures mentioned above work equally well with tangible and intangible types of attributes. But in instances where the decision makers prefer to talk of tangible attributes in terms of their dimension, more advanced utility assessment procedures can be used. For example, if the decision makers prefer to talk about the attribute in terms of dollars instead of utility, they may be accommodated. In order to obtain the utility for cost the decision makers must first specify the alternatives with the greatest and least cost. The utility curve for cost is then

constructed in accordance with the procedures outlined in Chapter 3. The cost utility for each alternative may now be determined from the cost utility curve.

A sensitivity analysis may still be performed when utilities are obtained from utility curves. If the decision makers' familiarity with the tangible attributes is sufficient, a more accurate sensitivity assessment procedure may be utilized. For instance, when the decision makers give a range of cost for a particular alternative, ask them to break this range so that there is an equal chance that cost will be above the break point and below it. Next ask the decision makers to break each of these intervals at the  $1/4$  and  $3/4$  probability points. These assessments give the decision analyst five points with which to construct a CDF (cumulative distribution function). A random number may now be generated in the cost range in accordance with the decision makers' CDF. The random cost determined in this manner may then be converted to a utility by entering the previously constructed utility curve.

#### A Perspective Look at Decision Analysis

A perspective look at decision analysis should be made at this point. Decision analysis may be appropriately applied as the apex of the planning procedure as it has been discussed and also in the "Analysis Phase," of planning procedures. In the "Analysis Phase," one primary alternative such as ground water development may include multiple ground water development possibilities. The attributes

for this decision subproblem may be a subset of the attributes important to the final decision problem. For instance, in a ground water development subproblem, important attributes relative to different ground water development alternatives may include only cost, quality and quantity. Thus, the techniques of decision analysis may be used to solve subproblems involving some or all of the primary alternatives. Proper application of decision analysis techniques, gained through experience, can reduce the complexity of the final decision problem to manageable proportions.

In summary, decision analysis techniques provide an extremely objective analysis of subjective considerations. Decision analysis is another tool available to the decision maker to clarify his best choices of action in complicated decision problems. It allows the decision maker to break a large decision problem into many smaller decision problems. Once the decisions on these small decision problems are quantified by utility theory, the respective decision makers have a focal point of mutual understanding much clearer than when they relied solely on words to express their views.

Applications of the general planning procedures of Fig. 4-1 will now be made for the Texas cities of San Angelo and San Antonio. The general water resources environment will be developed for each city followed by a detailed description of the specific problem chosen for solution by decision analysis techniques. Finally the detailed decision analysis solution including sensitivity analysis considerations will be presented.

CHAPTER 5  
THE SUPPLEMENTARY WATER RESOURCE DEVELOPMENT PROBLEM  
OF SAN ANGELO, TEXAS

The city of San Angelo is near the geographical center of Texas, about 200 miles northwest of San Antonio and 225 miles southwest of Fort Worth. Located on the Concho River, which is a tributary to the Colorado River, San Angelo is one of the major population and commercial centers of West Texas (see Fig. 5-1).

Physical Description of the San Angelo Area

Climate

The climate in the San Angelo area is characteristic of the Southern Plains region. The summers are hot and the winters are relatively mild. Rainfall is somewhat seasonal with the largest portions falling in late spring, summer and the early months of fall. Typical of the Plains region, the climate varies considerably from one year to the next.

Soils

The land of the Edwards Plateau which surrounds San Angelo has developed shallow soil from the underlying limestone. The usefulness of the soil is generally limited to grazing for livestock. The non-urbanized portions of Tom Green County, of which San Angelo is the County Seat, are stony and have a cover of mesquite, brush vegetation, native midgrasse and short grass. The bedrock

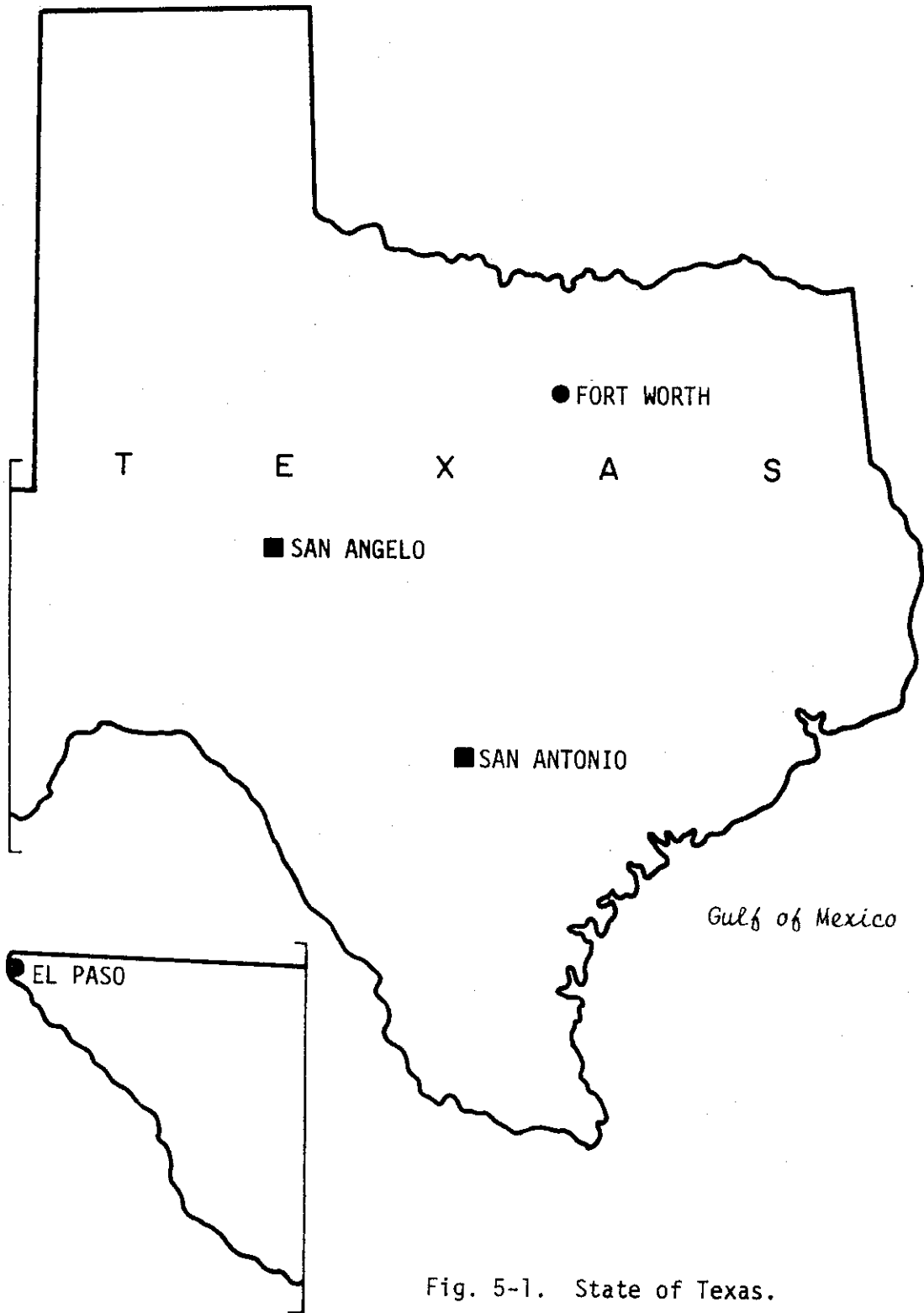

Fig. 5-1. State of Texas.

underlying the exposed in the Concho River basin is made up entirely of sedimentary strata of marine origin. A series of shale, limestone and sandstone beds of older Paleozoic sedimentary stratas several thousand feet in thickness underlie the entire area.<sup>[30]</sup>

In the Rolling Plains area to the east of San Angelo, the soil is a cover of river and outwash alluvium and is blanketed almost everywhere by kaolin deposits. This soil is very fertile, except in local areas of shallow bedrock, and is capable of producing high crop yields.<sup>[30]</sup> The Permian series constitutes the bedrock in this area and is exposed at scattered places in the Concho River valley. Older Paleozoic rocks are deeply buried but crop out in counties to the east.

#### Water Development

San Angelo has ready access to four of the major reservoirs in Texas. These reservoirs include Lake Nasworthy, Twin Buttes Reservoir, the San Angelo Reservoir and Lake E. V. Spence. The City of San Angelo owns Lake Nasworthy and the U.S. Government owns Twin Buttes and the San Angelo Reservoirs. The city also maintains a small reservoir, Bell Street, below the confluence of the North and South Concho Rivers for the purpose of backing up water in the South Concho for the city waterworks (see Fig. 5-2). The city has recently constructed a pipeline with a capacity of 13,200 acre-feet of water per year to the E. V. Spence Reservoir at Robert Lee, Texas, thirty miles north of San Angelo. The City presently has a contract with the Colorado River Municipal District for

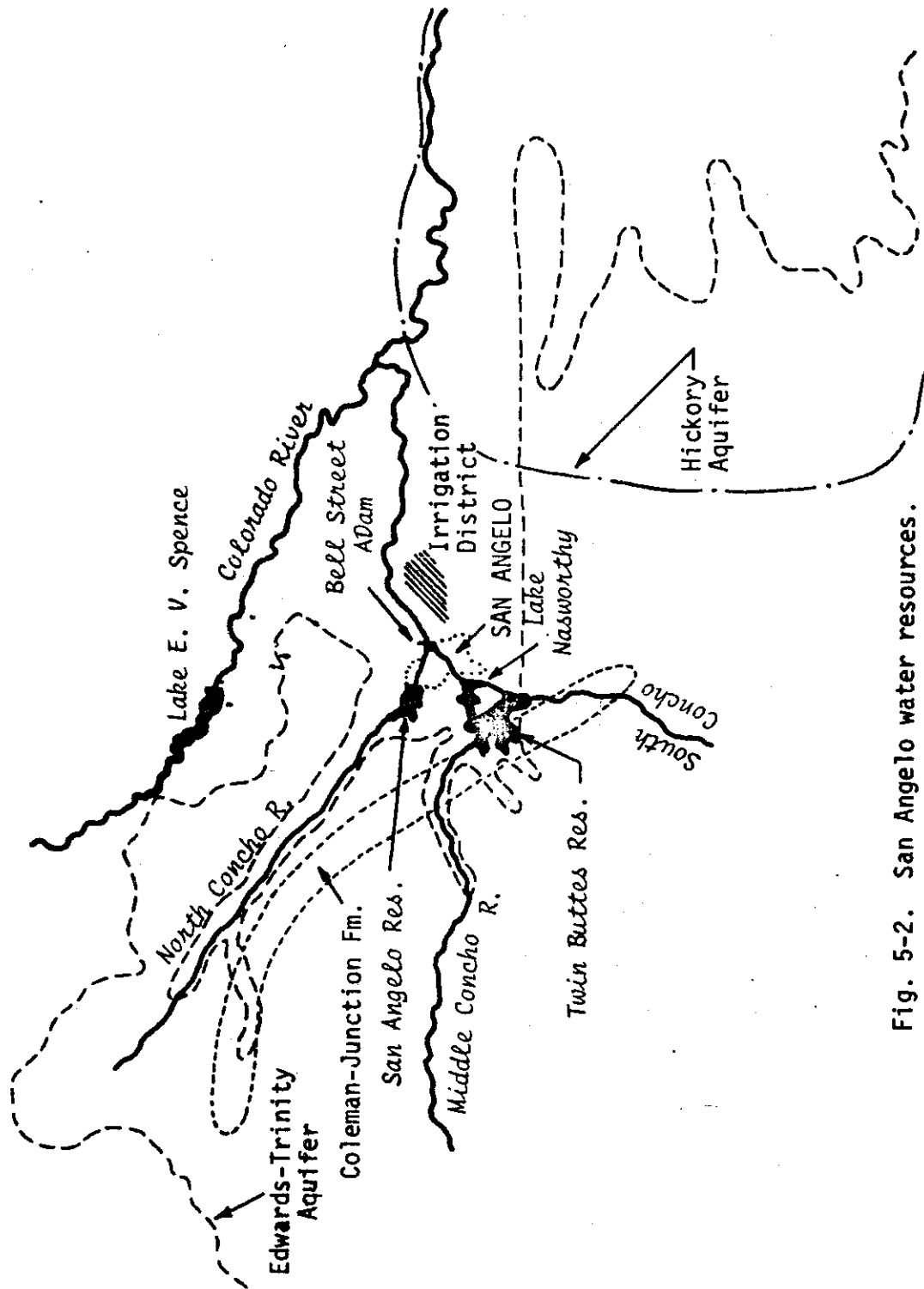

Fig. 5-2. San Angelo water resources.



3,000 acre-feet of water per year from Lake E. V. Spence. It has been estimated by Freese, Nichols and Endress<sup>[5]</sup> that San Angelo will consume 20,400 acre-feet of water per year by the year 2000 A.D. In the absence of drought conditions these reservoirs could be expected to supply San Angelo's water needs.

### Community

San Angelo is unique for the wide and diversified nature of the territory for which it is the financial, commercial and cultural center. The city is noted for its attractive park system, large potential water storage capacities, good industrial job opportunities and for being the site of Angelo State University.<sup>[30]</sup>

San Angelo has adequate transportation facilities. The Santa Fe Railroad provides the city with freight service. Texas International and several small local airline companies serve the city with air passenger and air freight facilities. Three major U.S. highways intersect at San Angelo: U.S. 277 runs north to south, U.S. 67 runs northeast to southwest and U.S. 87 runs northwest to southeast.

The City of San Angelo is presently weighted heavily towards light industry.<sup>[9]</sup> The only moderately heavy industry is that associated with the stock yards and packing plants located in the northeast section of the city. The light industry is primarily concentrated in the southwest, towards Lake Nasworthy. Industrial growth is expected to continue in the San Angelo area because of its location at the intersection of major highways and due to the railroad.

The population of San Angelo has grown from 52,093 in 1950 to 58,815 in 1960 and to 63,928 in 1970. This growth can be attributed to growth of the area's retirement community and employment opportunities in light industry. Because of large individual land holdings to the northwest and Goodfellow Air Force Base being situated to the east, the primary growth of the city is expected to be toward the west and southwest.<sup>[30]</sup> High industrial as well as residential growth is already being experienced in this area and its continued development is almost certain.

The San Angelo metropolitan area is expected to experience a reasonable growth. However, any major developments will depend primarily on a much needed dependable supply of water. Although San Angelo is not ideally situated for heavy industry, the potential for light industry is very good. There is a good labor market and with the growing retirement community the retail market should continue to expand. If the water resources become available, obvious markets are agriculture and water-based recreation.

### Water Resources Environment

#### Meteorology

The meteorological climate of the San Angelo area can be classified as semiarid or steppe-type. The humidity, however, tends to be higher than in many semiarid areas due to its proximity to the Gulf of Mexico.

The mean annual rainfall is approximately 20 inches with a large

portion falling in the form of convective showers or thunderstorms. Considerable frontal and thunderstorm activity occurs in late spring. The average number of days in which thunderstorms occur each year is 36. May is the month of maximum thunderstorm activity with an average of 7 days.

The mean temperature ranges from 85° during the summer to 47° in January. Daily maximum temperatures in August average 98°. These high temperatures during the summer months contribute to the high evaporation rate in the lakes and reservoirs near San Angelo. Net evaporation, based on pan measurements, averages 66 inches per year. [32]

#### Hydrology

There have been a number of severe floods on the Concho River. The largest known flood occurred in August of 1906, when an estimated flood peak of 246,000 cfs occurred in San Angelo. In September of 1936, a flood peak of 230,000 cfs was observed. Floods in excess of 100,000 cfs were observed in May of 1957 and in October of 1959.

Runoff in the Concho River basin is heavily influenced by rainfall intensity. When the annual precipitation is normal, a light rainfall intensity will produce a small amount of runoff and a heavy rainfall intensity will produce a large amount.

No significant long-term ground water supply in Tom Green County has been discovered. The Leona Formation of the Quaternary system and the Bullwagon Dolomite of the Permian system in north-eastern Tom Green County are shallow and have been mined

extensively.<sup>[34]</sup> An emergency supply source has been found at the northern edge of the Edwards-Trinity aquifer in southern Tom Green County. This area, referred to as the Huldale area, bears water in the Comanche Peak limestone of the Cretaceous system. The Texas Water Development Board<sup>[35,36]</sup> indicated that this general area is a promising short-term source of ground water for San Angelo.

A significant long-term water supply source has been identified in the Hickory aquifer in southwest McCulloch County, about 60 miles southeast of San Angelo. The Hickory Sandstone is a member of the Riley Formation of Cambrian age.<sup>[32]</sup> Thickness of the aquifer ranges from a few feet at the outcrop to a maximum of 500 feet. Depth of wells completed in the Hickory Sandstone range from 2000 to 2800 feet and the water is under artesian conditions.

The Coleman-Junction Formation in eastern Tom Green County contains a large volume of saline water. This formation is approximately 150 feet thick and the salt water is under artesian pressure. Conservative estimates of the capacity of this formation indicate the presence of over 40,000,000 acre-feet of salt water.<sup>[32]</sup>

#### Water Quality

The surface water quality in the San Angelo area has been good historically. However, recent problems have occurred due to the prolonged drought during 1965-71 which resulted in low flow and high evaporation rates. This quality problem was observed from samples collected upstream of the Bell Street Dam where the intake of the city water supply is located. By the end of the summer, in

1971, the total dissolved solids was measured as high as 1300 mg/l. During periods of low flow, very little water leaves the Concho River below this dam. This in-town reservoir collects about one-half of the urban runoff from San Angelo. The feed lots in the north-eastern part of the city are suspected of being heavy water polluters during high runoff periods.<sup>[30]</sup> Fortunately, this is reflected in stream quality below the Bell Street Dam and does not affect the local water supply significantly.

Ground water quality in the immediate vicinity of San Angelo is relatively poor.<sup>[34]</sup> However, water quality in the Huldale area and in the Hickory aquifer is generally quite good. The quality of water in these later mentioned areas varies from well to well. Some wells do yield large amounts of nitrates, iron, chloride, sulfate, fluoride or calcium due to the individual characteristics of different limestone formations. Water in the Coleman-Junction Formation is considered too highly mineralized for economic use in the opinion of the Texas Water Development Board.<sup>[32]</sup>

#### Water Resources Management Systems

Effective water resources planning in the San Angelo area involves coordination of the multitude of agencies, listed in Chapter 4, that exercise control of water resources. There is no overall Water Resources Management System as such in the San Angelo area. The City of San Angelo is, however, the primary decision execution agency. The capacity of the Concho Valley Council of Governments is primarily advisory.

The City of San Angelo coordinates most of the water-based activities for the reservoirs in the area. Through a Lake Board, the city controls the waterfront usage on Lake Nasworthy which is inside the city limits. Since both Twin Buttes and San Angelo Reservoirs are government reservations, there are no private residences on the lake fronts and the Corps of Engineers plus the Bureau of Reclamation control commercial activity nearby.

#### The Supplementary Water Resources Development Problem

In the past San Angelo has relied almost exclusively on surface water in the before-mentioned reservoirs. However, there was a decline of available water in the reservoirs from the late 1950's until the end of the 1960's. The available water reached a critical point between 1967 and the beginning of 1971. At the end of this period, San Angelo Reservoir was completely dry, Twin Buttes had 2,100 acre-feet, Lake Nasworthy held about 6,400 acre-feet and Lake E. V. Spence was critically low. This critical water shortage was the catalyst for investigations of water resources development alternatives. Thus, a decision analysis problem for the selection of a best alternative for supplementary water resources was formed. It should be noted at this point that this decision problem has been solved and the solution is currently being implemented. The actual decision was made without the aid of decision analysis techniques. Accordingly, this water resources development case-study is a reflective look at an urgent decision problem still fresh in the

minds of the decision makers in San Angelo.

The individuals who supplied the data for this decision study include most of the professional and public figures in San Angelo who are deeply concerned with the problem of supplementary water resources development.

The initial decision flow diagram for water resources development for San Angelo is essentially the same as the one in Fig. 4-2 (p. 40). Necessary adaptations include: (1) Armistead Lake and Stacey Lake are two fresh water reservoir sites; (2) the Hickory, Edwards-Trinity and Coleman-Junction aquifers are the three aquifers for ground water development; and (3) the rivers and streams alternative is not applicable to San Angelo.

This initial decision flow diagram was reduced in the Analysis Phase of Fig. 4-1 (pp. 33-34) to a manageable proportion. This reduction was enabled due to legal, political, engineering, economic and environmental constraints. The feasible and infeasible alternatives are described herein.

When research was begun in 1970 to determine a ground water supply to supplement San Angelo's surface water supply, the Hickory aquifer was selected as the most promising long-term supply source. This source appeared to be more than sufficient for meeting San Angelo's supplementary water needs. The Texas Water Development Board has estimated the annual recharge to this aquifer to be nearly 7,000 acre-feet per year.<sup>[36]</sup> An enormous quantity of water exists in this aquifer that could be used in addition to this

7,000 acre-feet per year if extended drought conditions prevailed. The water is of good quality, about 350-400 mg/l of total dissolved solids. The only apparent drawback of developing this aquifer is the high cost of constructing a pipeline to carry the water back to San Angelo. The cost of developing this source has been judged to be as high as \$400,000 per year over a twenty-five year period. This estimate includes drilling, pumping, water rights, and pipeline costs. Construction of the pipeline can be delayed, however, as long as the supply of water in the reservoirs is sufficient to meet the demands of the near future.

A second alternative San Angelo had was to invest in the construction of the proposed Stacey Reservoir, which was proposed in the Texas Water Plan. This reservoir is to be located on the Colorado River, downstream of Lake E. V. Spence, about 50-60 miles northwest of San Angelo. The quality of water in the Stacey Reservoir is estimated to be in the range of 1000-2000 mg/l of total dissolved solids. Construction of the Stacey Reservoir has been proposed for the 1980's.

Weather modification techniques, commonly termed cloud seeding, have been tested in the San Angelo area for two years by Meteorology Research, Inc., with funding from the Bureau of Reclamation. Experiments on smaller cloud formations have been conducted. Possible benefits from seeding large storm formations had largely been speculated on. The most beneficial strategy for the application of cloud seeding techniques had not been determined. From the



viewpoint of increasing surface runoff the most productive strategy would probably be to seed a few large storms in order to increase their productivity. The safe strategy would be to seed a number of marginally-productive storms to avoid possible storm damages or even possible flood damages. Unfortunately, the primary runoff which supplies the reservoirs in the San Angelo area comes from one or two large storm formations a year. Smaller formations do not produce significant surface runoff. Estimates on the incremental gain from seeding the large storm formations vary considerably with maximum estimates being in the range of 5,000 to 8,000 acre-feet per year.

In the recent past San Angelo had looked southward for an emergency water supply to the Edwards-Trinity aquifer in the Hulldale area. The water there is of good quality but the quantity was marginal for meeting the heavy pumping that would be necessary to meet San Angelo's supplementary water needs over an extended period of time. It was possible to acquire the riparian water rights along the South Concho River which flows through the Hulldale area and pump water from wells in existence in this area to the South Concho which flows into the south pool of Twin Buttes Reservoir. Another possibility would have been to construct a 25 mile pipeline to transport the water to San Angelo without the evaporation losses that the South Concho route would incur. Extensive environmental damage would have resulted, however, from continued use of this source. Even dependence on this source as an emergency supply

would have resulted in a loss of good will from farmers and ranchers in this area who depend on that water for their livelihood.

The least expensive alternative available to San Angelo unfortunately offered the least incremental quantity. A new wastewater treatment plant was to be built in order to satisfy the effluent requirements of the Texas Water Quality Board. This new treatment plant would necessarily have the improved feature of a secondary water treatment process. The effluent from this treatment plant could safely be used in the irrigation district east of San Angelo since the crops there are non-human consumable. The irrigators in this area had a contract with San Angelo for use of water in Twin Buttes Reservoir in excess of 50,000 acre-feet. The dependable supply of secondary treated wastewater would have been advantageous to the farmer and his demands for water in Twin Buttes Reservoir would have been reduced. Unfortunately, the evaporation losses in Twin Buttes Reservoir are extremely high, especially above 50,000 acre-feet. Thus the incremental quantity gained by the city would have been small.

A number of other alternatives were available to San Angelo. Each, however, contained at least one serious flaw which eliminated it from the set of feasible alternatives. The Armisted Lake on the Rio Grande River would have required an extensive pipeline. Desalination of water from the Coleman-Junction Formation west of town would have entailed a monumental waste disposal problem. Construction of a dual water supply system for the city would have a

tremendous plumbing cost and would have the inherent danger of contamination due to cross-connections of pipelines. Construction of in-town surface reservoirs had been proposed at several sites but these offered only an increased catch of very poor quality urban runoff. The Hickory aquifer in McCulloch County had been mentioned as a primary water supply. This would have relegated the reservoirs currently in use to irrigational and recreational purposes. In the long run there may have been extremely harmful effects to the environment in McCulloch County and also to the residents of Brady and Melvin, Texas, who rely on this water for their municipal supply. Managerial adjustments and relying on good fortune were very unpopular politically. Recycling was also discussed as a source for San Angelo and will remain a possibility in the future due to the fact that the new waste-water treatment plant was designed so that a tertiary treatment process can be added if desired.

#### Attributes

Each of the preferentially independent attributes listed in the general water resources model in Fig. 4-2 was applicable to San Angelo's water resources development decision problem. The social-economic attribute was broken into three smaller attributes. These refined attributes considered important in differentiating between the feasible alternatives were environmental degradation, economic growth potential and social acceptance. Dependability was included in the list of attributes due to San Angelo's total reliance on surface water. As mentioned before, dependability is influenced by

the quantity of water available but an abundant quantity does not necessitate a high dependability utility rating.

### Sensitivity Analysis

The initial decision flow diagram for San Angelo was compressed into the diagram shown in Fig. 5-3. Note that the probability in the initial decision flow diagram are included as consequences of the final decision flow diagram. A cumulative probability function was assessed over the ranges of the quality, cost and quantity attributes for each alternative. This data is displayed in Fig. 5-4. A cumulative probability distribution function was used in lieu of the probability nodes with a discrete number of branches to enable the calculations for a sensitivity analysis. If a sensitivity analysis is not desired, the probability nodes with discrete branches should be retained in the final decision flow diagram.

The cumulative distribution functions for the quality, cost and quantity attributes, of each alternative, were fit with a third-order polynomial using least squares techniques. The x and y axes were interchanged before fitting the polynomial to the data points. This allows easy conversion of a random variable to a random attribute value.

A second-order polynomial was fit to the utility data presented in Fig. 5-5 using least squares techniques. A smooth curve was drawn through the decision makers' utility data to illustrate that the decision makers had risk averse utility curves.

ALTERNATIVES	ATTRIBUTES							
	Quality (tds)	Cost (\$/yr)	Quantity (acre-ft/yr)	Dependability	Flexibility	Env. Deg.	Economic Growth	Social Accept.
(1) Hickory aquifer	350-	350,000-	8,000-	.95- 1.	.95- 1.	.9 - 1.	.95- 1.	.9 - 1.
	400	400,000	15,000					
(2) Stacey Reservoir	800-	500,000-	8,000-	.0 - .1	.95- 1.	.4 - .5	.5 - .6	.4 - .5
	1100	550,000	12,000					
(3) Cloud seeding	550-	80,000-	5,000-	.3 - .4	.0 - .1	.3 - .4	.3 - .4	.4 - .5
	750	100,000	8,000					
(4) Huldale area	200-	120,000-	1,800-	.5 - .6	.4 - .5	.0 - .1	.0 - .2	.0 - .2
	300	140,000	2,500					
(5) Recycled water for irrigation	550-	9,000-	3,000-	.6 - .65	.1 - .2	.7 - .8	.4 - .5	.7 - .8
	750	11,000	3,500					
<u>WEIGHTS</u>	.12	.1	.21	.22	.13	.05	.1	.04

Fig. 5-3. Final decision flow diagram for San Angelo.

ALTERNATIVES	ATTRIBUTES			
	Quality (tds) (CDF Probability Points)	Cost (\$/yr) (CDF Probability Points)	Quantity (acre-feet) (CDF Probability Points)	
	.0 .25 .5 .75 1.	.0 .25 .5 .75 1.	.0 .25 .5 .75 1.	
(1) Hickory aquifer	300 410 425 440 500	350,000 370,000 385,000 380,000	13,000 12,500 13,500 8,000 15,000	
(2) Stacey reservoir	700 925 950 975 1200	500,000 525,000 535,000 530,000	10,750 10,500 11,300 8,000 12,000	
(3) Cloud seeding	300 575 600 625 900	80,000 89,000 91,000 90,000	6,800 6,500 7,100 5,000 8,000	
(4) Huldale area	100 180 200 220 300	120,000 128,000 132,000 130,000	2,075 2,000 2,150 1,800 2,500	
(5) Recycled water for irrigation	300 500 525 550 900	9,000 9,800 10,200 10,000	3,200 3,150 3,250 3,000 3,500	

Fig. 5-4. CDF data.

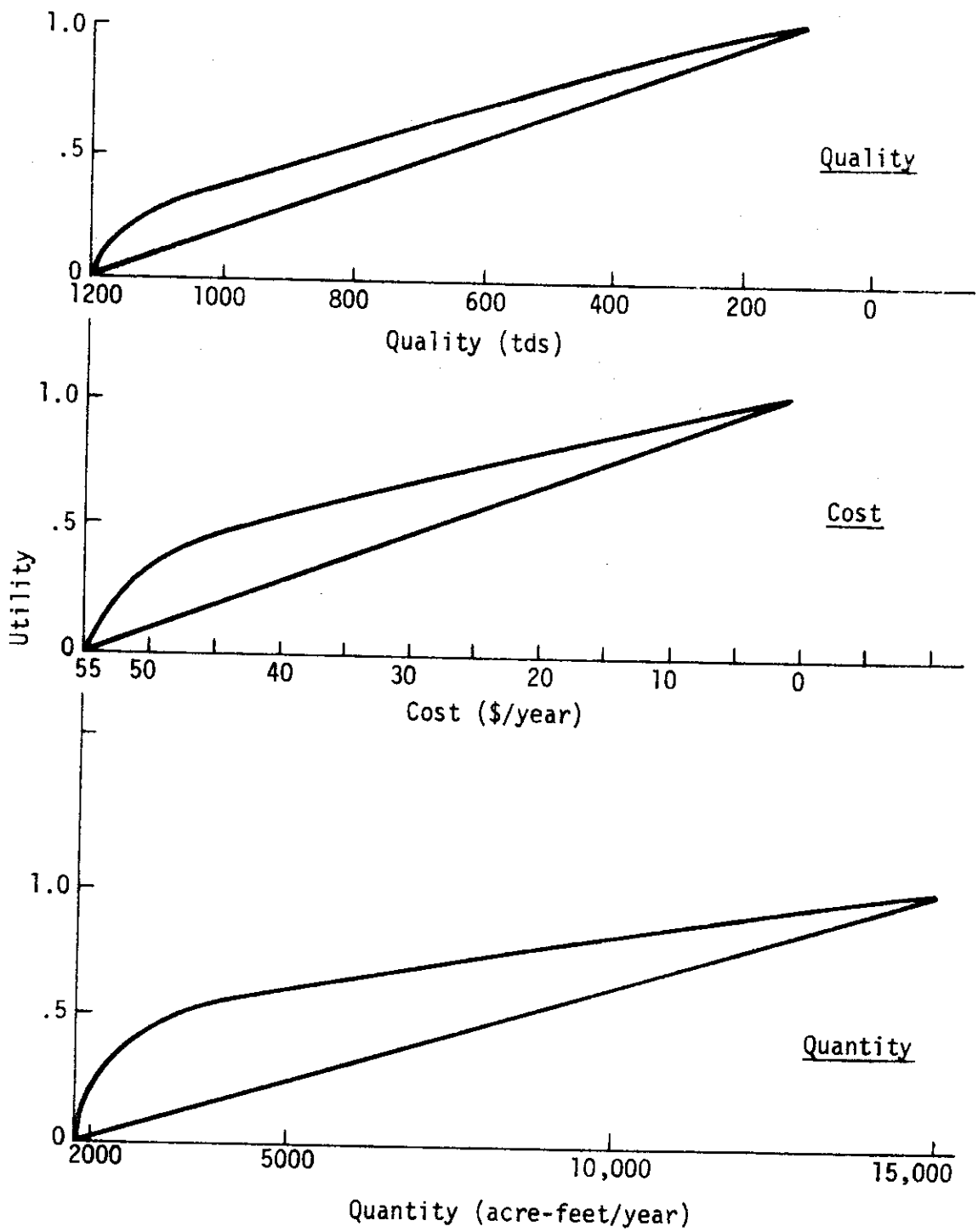

Fig. 5-5. Utility curves.

Random utilities for the cost, quality and quantity attributes were obtained by (1) generating a random number, (2) converting this random number into a random attribute value, and (3) converting the random attribute value into a random utility. Random utilities for the other attributes were generated in a straightforward manner. This was accomplished by multiplying the absolute value of the difference of the attribute range end points by a random number and adding this value to the lower end point of the attribute range.

Since the sum of the weights was 1. and preferential independence and utility independence conditions could be satisfied, the additive utility function, Equation (3-1), was used to calculate the utility of each alternative. Random utility values for each attribute of each alternative were simulated 200 times on an IBM 360 Model 65 computer. The computer program used can be found in Appendix III.

The utility distribution of each alternative is shown in Fig. 5-6. Figure 5-6 has been traced from the utility distribution curves of each decision alternative. The individual alternative utility curves can be found in Appendix III.

The decision analysis solution to this decision problem is rather apparent after an inspection of Fig. 5-6. The most preferred decision alternative is clearly the development of the Hickory aquifer in McCulloch County, Alternative 1. Fortunately, this is the alternative that was selected and implemented in San Angelo.



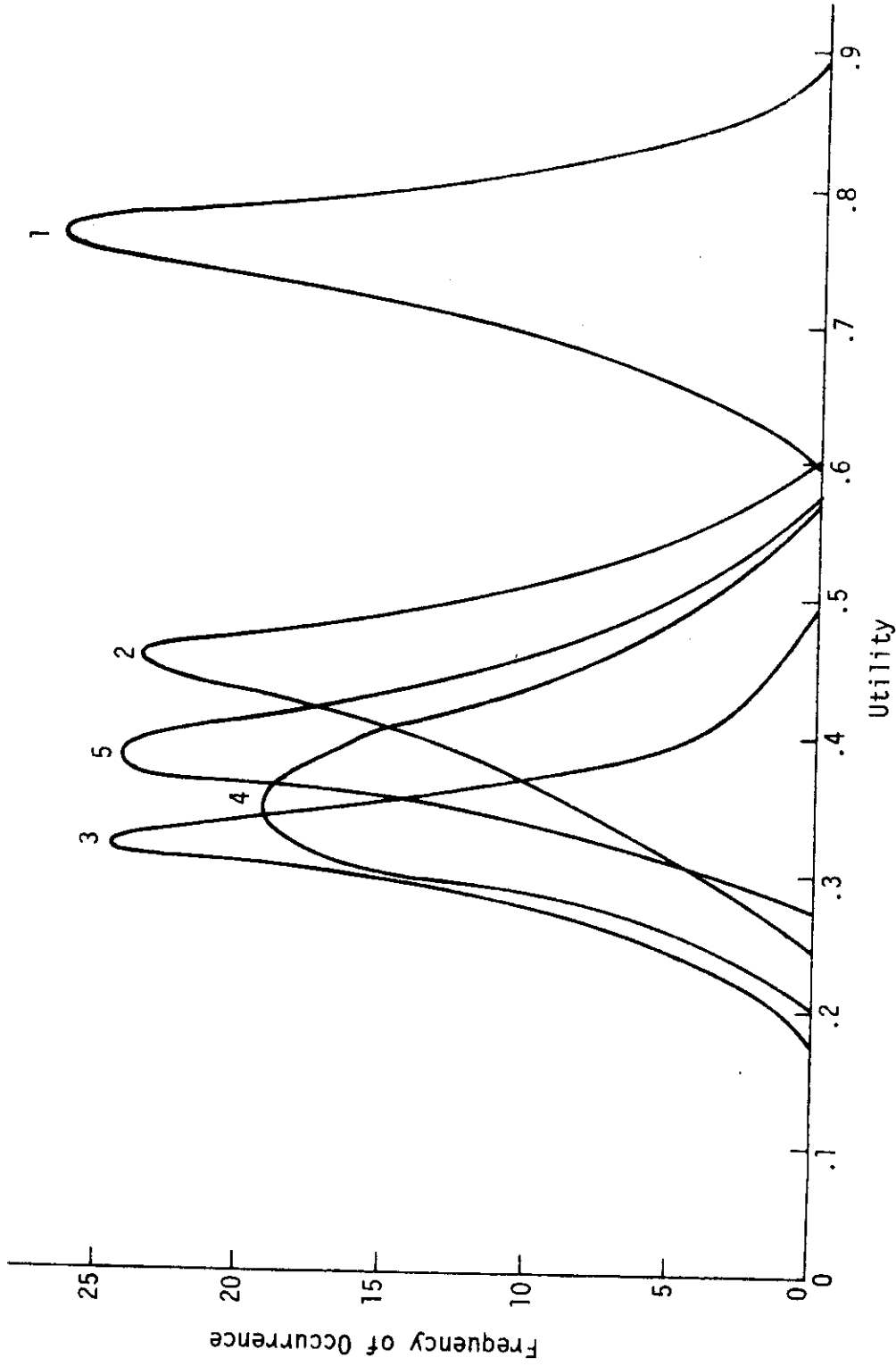

Fig. 5-6. San Angelo utility distribution graphs.

## CHAPTER 6

## WATER-BASED RECREATION IN SAN ANTONIO, TEXAS

San Antonio, the county seat of Bexar County, is located in South Central Texas. San Antonio is an old city that lies in the center of a densely populated area. The City of San Antonio is the fifteenth largest city in terms of population in the United States. San Antonio is the largest city in the world which depends on ground water as its principal supply source.<sup>[8]</sup>

## Physical Description of the San Antonio Area

Climate

The location of San Antonio on the edge of the Gulf Coastal Plains has resulted in a modified subtropical climate. The San Antonio River divides the semiarid area to the west and the tropical coastal area to the southeast. The climate is predominantly continental during the winter months and marine during the summer months. San Antonio is popularly known as the "place where the sunshine spends the winter."<sup>[33]</sup>

Soils

The topography surrounding San Antonio is quite diversified. The southwest portion lies on a prairie and bush-covered coastal plain. The northwest portion lies above the Balcones Escarpment which traverses Bexar County from northeast to southwest with rugged hills. Soils in the south and east are clay and sandy loam, quite

suitable for the extensive cultivation they receive. The thin soil above the Balcones Escarpment is used primarily for livestock grazing.

#### Water Resources Development

The City of San Antonio derives water for municipal, industrial, irrigational and domestic purposes from the Edwards aquifer which crosses the central part of Bexar County. This aquifer is 5 to 30 miles wide and extends over 175 miles. It is composed of hard massive limestone, dolomitic limestone and marbly limestones of the Edwards, Comanche Peak and Georgetown Formations.<sup>[33]</sup> The thickness of this aquifer ranges from 400 to 900 feet. It yields approximately 260,000 acre-feet of water per year to users in the San Antonio River Basin. There is an adequate quantity of water in the aquifer such that users are not faced with immediate water shortages. However, a long range planning program should be initiated to identify additional water sources for the future.

Although the San Antonio area depends solely upon ground water to meet the water needs of its population, there is a limited amount of surface water available. Numerous lakes and reservoirs including Canyon, Medina, McQuency, Dunlap, Brauning, Calaveras and Mitchell, exist in the vicinity or actually inside the City Limits of San Antonio. These lakes and reservoirs are man-made and are used primarily for flood control, waste treatment, power generation, and restricted recreation such as boating. The quality of water in these lakes does not permit extensive recreational activities.

### Community

San Antonio is an active business community and the San Antonio River Basin is well developed with both agricultural and commercial enterprises. There is relatively little industrial activity in the San Antonio area; hence, the economy depends heavily on military complexes and tourism.

Since Spanish days the military has been an integral part of San Antonio. Fort Sam Houston, headquarters for the Fifth Army, was founded in 1878. Four major Air Force bases--Lackland, Brooks, Kelly and Randolph--are also located in San Antonio. This concentration of military installations is a great asset to the local economy.

Due to historic significance, geographical location and municipal encouragement of recreation development, San Antonio is one of the major tourist areas of Texas. Millions of people travel to San Antonio to see the historical sites which have played an important part in the development of Texas. These historical tourist attractions include: the Alamo, the Spanish Governors' Palace and the San Antonio Missions. Recreational attractions in the area which stimulate tourism include: the San Antonio Zoo, the River Walk, the Hemisfair Plaza, the San Antonio Festival and the River Theater. San Antonio's pursuit of tourism produces a large economic return of money and goods. Thus, a total regional development of San Antonio's water resources systems should emphasize the development of water-based recreational facilities.

## Water Resources Environment

### Meteorology

San Antonio has an annual rainfall of approximately 28 inches. Precipitation is well distributed throughout the year but is heaviest during the months of May and September. Precipitation from April through September is usually in the form of thunderstorms. Most of the winter rain occurs as drizzle. Light hail frequently falls in connection with springtime thunderstorms but is seldom damaging. Measurable snow falls once every three or four years.<sup>[33]</sup>

Northerly winds generally prevail during the winter. During the summer southeasterly winds come from the Gulf of Mexico, sometimes bringing tropical storms with heavy rains.

Normal temperatures range from a mean of 52° in January to a mean of 84° in July. Extremely high temperatures are rare. Relative humidity averages above 80 percent during the early morning hours and drops to an average of 50 percent in late afternoon.

### Hydrology

The San Antonio River Basin has a drainage area in excess of 4,100 square miles. The basin includes parts of two different physiographic provinces, the West Gulf Coastal Plain of the Coastal Plain Province and the Edwards Plateau of the Great Plains Province. These physiographic provinces are separated within the basin by the Balcones Escarpment.

The principal stream that drains the Edwards Plateau section

of the basin is the Medina River (see Fig. 6-1). It flows eastward across the Edwards Plateau and joins the San Antonio River about 15 miles south of the City of San Antonio River. The main-stream of the San Antonio River rises in the city of San Antonio, near the center of Bexar County, and flows southeastward across the West Gulf Coastal Plain. The West Gulf Coastal Plain extends from the Balcones Escarpment to the Gulf of Mexico. Cibolo Creek, the principal tributary to the San Antonio River, rises in the Edwards Plateau, flows southeastward across the Balcones Escarpment and West Gulf Coastal Plain and joins the San Antonio River southeast of San Antonio.

Springflow from the Edwards aquifer in the Edwards Plateau contributes to the flow of the Medina River and Cibolo Creek. Much of this flow penetrates the Balcones Fault Zone at the outcrop of the Edwards aquifer. This often results in little or no streamflow south of the Balcones Fault Zone.<sup>[8]</sup>

#### Water Quality

Water in the Edwards aquifer is of very good quality although very hard. This water generally contains less than 500 mg/l of dissolved solids except where the formation is 1,000 feet or more below sea level. There the water becomes brackish and contains as much as 10,000 mg/l of dissolved solids.

The quality of waste-water in the San Antonio area has become a problem. During the last twenty-five years, the quality of water in the San Antonio River has degenerated from crystal clear spring

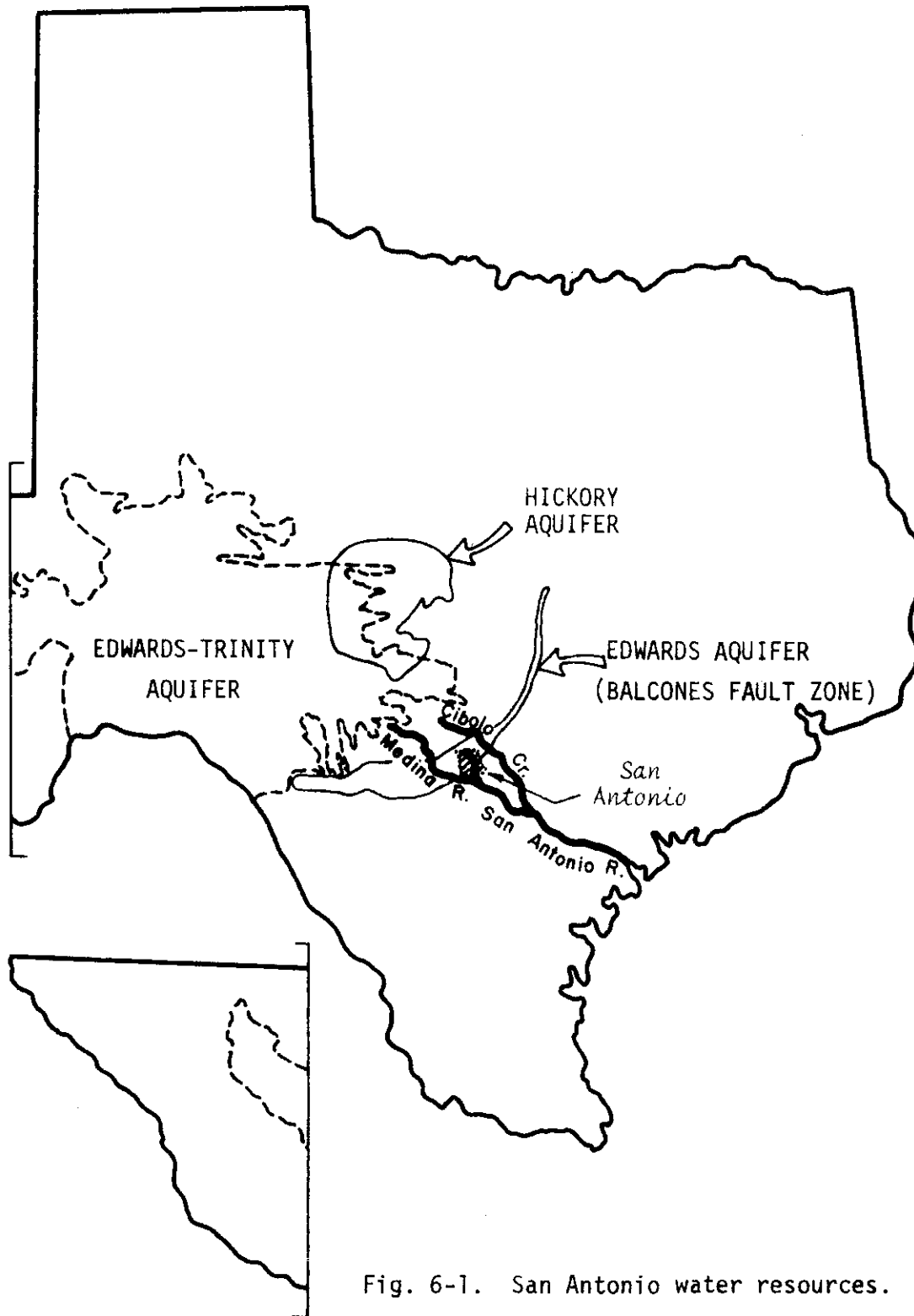

Fig. 6-1. San Antonio water resources.

water to murky, oxygen deficient water which transports the diluted, treated waste effluent of the San Antonio metropolitan area. The major source of pollution is domestic sewage which is generated by nearly one million inhabitants of the area. A solution to this problem will require cooperation among the institutional, financial, administrative and governmental organizations in the San Antonio area.

#### Management Systems

Water resources management in San Antonio is an intricate and complex network of overlapping government agencies. Twenty such agencies that have water resources responsibilities in San Antonio were mentioned in Chapter 4. In addition, there are approximately thirty private water companies with vested interest in water resources planning. A summary of the activities of three of the most important water agencies in the San Antonio area is contained herein.

The San Antonio City Water Board is the largest supplier and distributor of water in Bexar County. It is chiefly concerned with the development of additional water resources and with the conservation of the existing supply. The Board has participated in various programs designed to develop means of recharging the Edwards aquifer and to develop supplemental surface water supplies from the surrounding areas.

The San Antonio River Authority is a conservation and reclamation agency. The River Authority is empowered to construct,



maintain, and operate navigable canals and waterways and to implement flood control, soil conservation, sewage treatment and pollution control measures. Also the River Authority is responsible for developing parks and recreational facilities.

The Alamo Area Council of Governments (AACOG) is a regional planning organization with headquarters in San Antonio. The organization consists of ten member counties, each pays dues to support the organization. AACOG has been especially active in studying the water resources of the area and in helping promote programs for the improvement of water quality.

A short description and summary of each of the agencies which have jurisdiction over water resources in the San Antonio River Basin may be found in reference 8. It is fortunate for San Antonio that these public organizations are cooperating among themselves toward the common goal of water resources planning.

It has been realized by most of the San Antonio water resources management agencies that the development of more water-based recreation must be emphasized. Public demand for water-oriented recreation within the San Antonio area has grown phenomenally in the past few years. And as leisure time increases, so will the economic impact of recreation. Hence, the development of San Antonio's water-based recreation is now becoming the primary concern of local economic planners as well as politicians.

### The San Antonio River Walk

The River Walk is considered an important tourist attraction for San Antonio as well as a recreational facility. This use of the mile-long horseshoe bend of the San Antonio River is as successful and imaginative as can be found in the United States (see Fig. 6-2). Although originally built as a flood prevention program, effective political efforts have turned the River Walk area into an aesthetically pleasing recreational area. The River Walk encompasses an area of about twelve blocks in the central business district of San Antonio. The river in this horseshoe bend is kept at constant depth by augmenting the river flow with water from deep wells. The River Walk lies in a deep cut, about twenty-five feet below the street level, and is flanked by huge trees, lush plant growth, shops, restaurants and hotels. A continuous promenade parallels the river on both sides and the forty-foot river is bridged many times to allow for automobile and pedestrian crossing. [12]

Visitor activities for the River Walk patrons are quite varied. Sightseeing on foot and strolling along the river bank is popular with the River Walk users. Downtown workers, students, shoppers and elderly people use the River Walk as a pleasant pedestrian route rather than selecting congested street-level arteries. Pedal boating is also popular with visitors. This is the only "muscle" activity on the River Walk other than walking or strolling. Small wildlife is present and visitors often stop to feed the songbirds

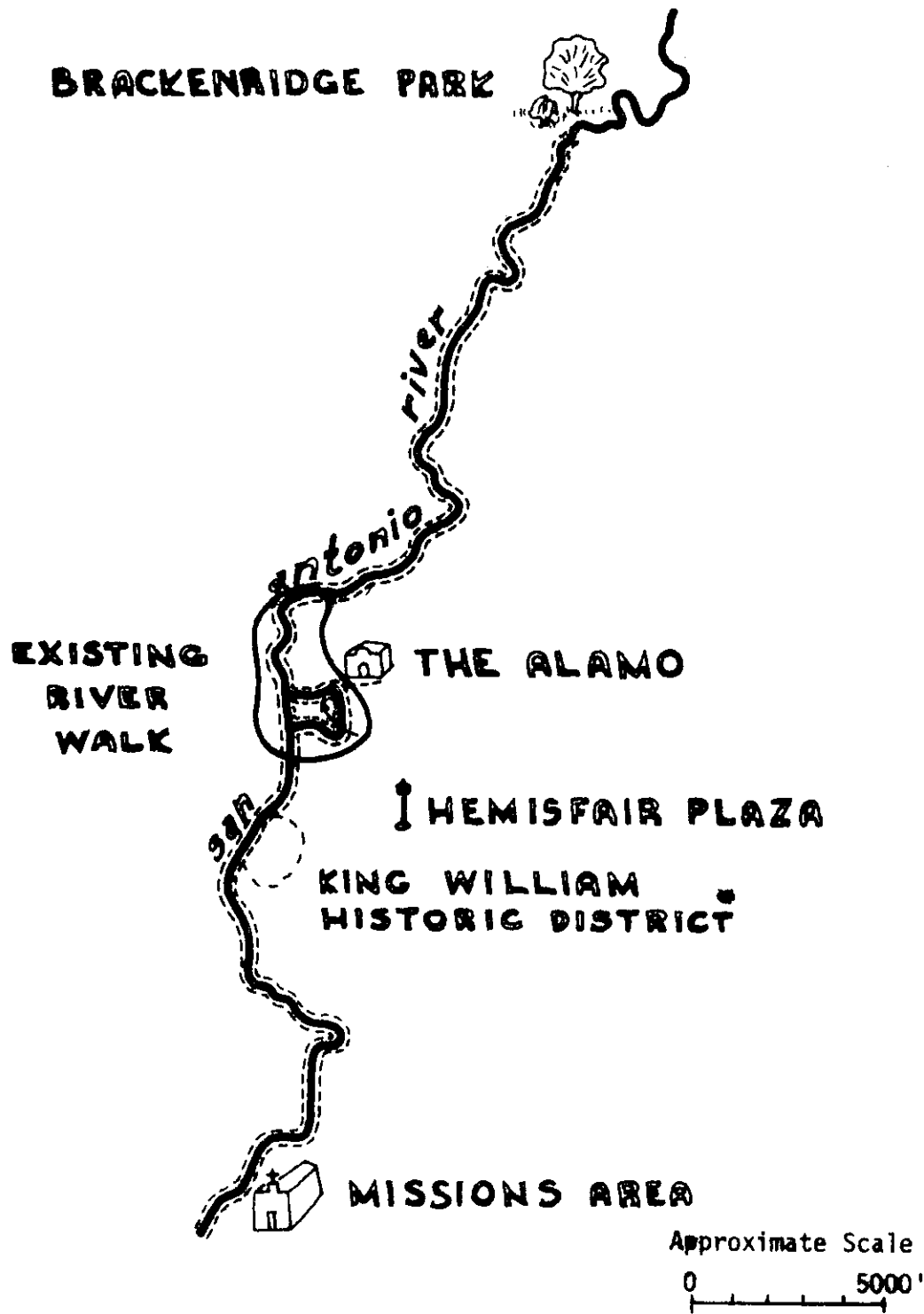

Fig. 6-2. Water-based recreation on the San Antonio River.

and pigeons.

The River Walk presents the user with many areas for relaxation and solitude. The low elevation of the River Walk protects the user from the intensive activity above. Sightseeing barges run at capacity during most of the summer days. Boats may also be rented for private dinner parties and floating business seminars. Residents of San Antonio proudly use their River Walk to entertain guests.

Night clubs, the Arneson River Theater and special events provide entertainment on the River Walk. Dining and lodging services accommodate the tourist, conventioner and resident alike. Restaurants use the river terrace for outdoor dining. Minstrels frequently entertain river patio guests.

The San Antonio River Walk is succeeding very well in spite of the trend in most cities toward decay of the urban core. Visitors to the River Walk are fully conscious of its beauty and leisure qualities. Testimony is very strong from voters and outside visitors of the great social value as well as the economic value of the River Walk. This overwhelming success has led to plans for expansion of the present River Walk.

#### The River Walk Expansion Decision Problem

Due to potential increases in economic growth and recreational benefits, the city of San Antonio is considering expanding its River Walk. The decision analysis case-study contained herein is a preliminary identification of the most preferred expansion

alternatives available to the city.

Decision makers who participated in this decision analysis case-study include many public and professional people in San Antonio interested in the development of water-based recreation.

### Attributes

The attributes selected as being important for this decision problem include: urban enhancement, economic growth, cost, recreation, and social acceptance. An important attribute not included in the analysis is flood control. The reason for this is that flood control does not help differentiate between the different expansion alternatives. None of the alternatives enhance or degrade present flood control measures. Another way of saying this is that if flood control were included as an attribute, the utility of flood control would be the same for each decision alternative. However, flood control is considered as being a necessary addition to any expansion alternative selected.

Definitions of four of the five attributes selected for this preliminary identification study deserve a review and some need modification. This is partially due to the different nature of San Antonio's water resources development decision problem and also because four of these attributes fall in the grouped attribute category of social-economic impact. Urban enhancement includes the enhanced attractiveness of the city plus improved living facilities in the River Walk vicinity. Economic growth is redefined as the potential increase in commercial trade felt by the entire city.

Social acceptance is still intended to be a reflection of voter attitudes and recreation is again defined as the aesthetic feeling of serenity and leisure plus physical activities such as paddle boating.

The cost attribute will be assessed in a different manner than was done in the San Angelo case-study. This is due to the "soft" facts on cost available to San Antonio at the time of this preliminary study. Many cost estimates had already been made in San Angelo before the decision study was made. For this reason, the utility for cost will be assessed in a subjective manner without first specifying a CDF and a utility curve.

#### Alternatives

The alternatives applicable to this decision problem are totally different than those of the general water resources decision model proposed in Chapter 4. The River Walk expansion alternatives are combinations of three basic possibilities. One is northward expansion to Brackenridge Park; another is southward expansion to the Missions area; and another is eastward expansion to the Alamo. The northward and southward expansions can utilize the existing San Antonio River channel. The eastward expansion to the Alamo would involve digging a short man-made channel from the present River Walk.

The decision flow diagram for this decision problem is shown in Fig. 6-3. The chance nodes in Fig. 6-3 can be converted into consequences as was done in the San Angelo problem so that a sensitivity analysis may be performed. The resultant decision flow

Social-Economic

favorable  
indifferent  
unfavorable

Cost

high

low

DECISION FLOW DIAGRAM FOR SAN ANTONIO

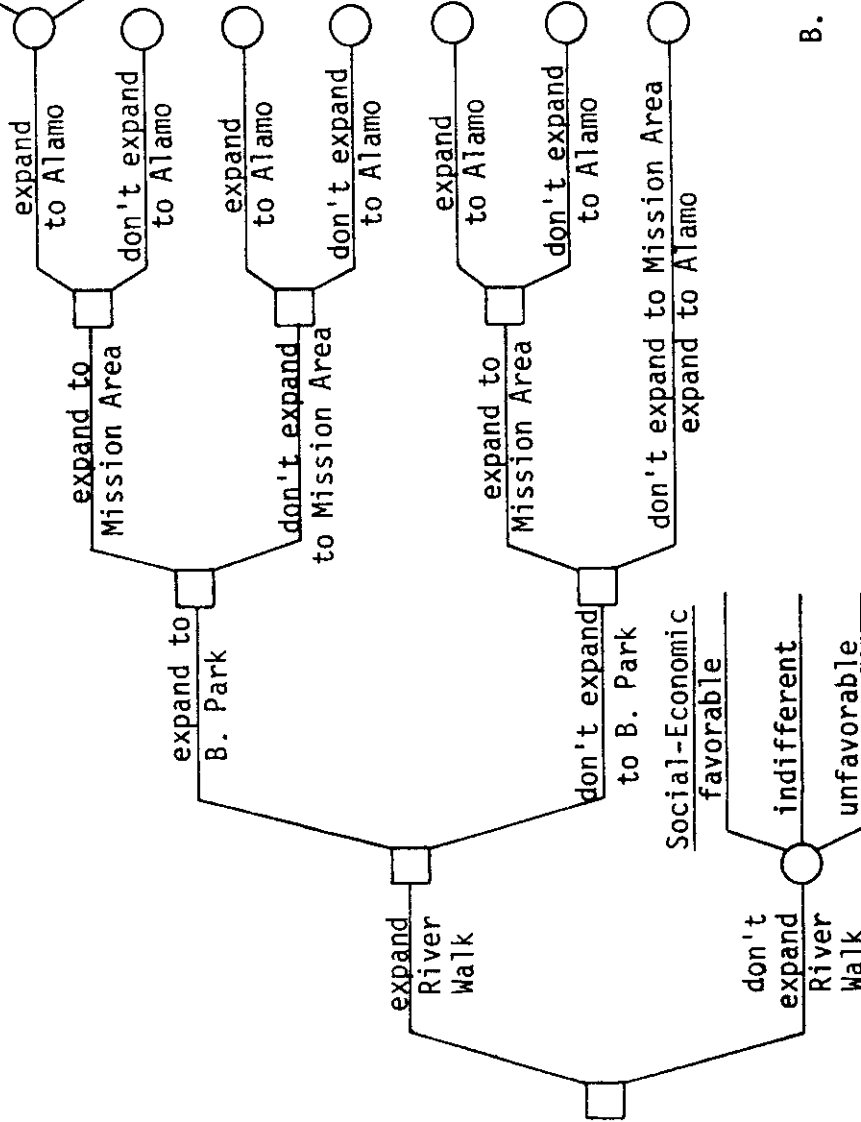

B. Park: Brackenridge Park

Fig. 6-3. Decision flow diagram for San Antonio.

diagram along with the utility assessments and weights is presented in Fig. 6-4.

Since the sum of the weights was 1. and preferential and utility independence conditions were satisfied, the additive utility function, Equation (3-1), was used to calculate the utility of each alternative.

#### Sensitivity Analysis

A sensitivity analysis was performed on the utility data in Fig. 6-4 using the same procedure as that explained in Chapter 5. This decision problem was simulated 100 times. The utility distribution graphs in Appendix III have been combined into one graph which is pictured in Fig. 6-4. The standard deviations of the utility curves of each alternative in Fig. 6-4 are obviously smaller than the standard deviations of the utility curves in Fig. 5-6 (p. 74). This is due to the wide attribute ranges of the quality, cost, and quantity attributes in the San Angelo problem.

One conclusion that can be drawn from the San Antonio sensitivity analysis is that the consensus of opinion among the decision makers consulted is that Alternative 7 (expand to Brackenridge Park, the Missions area and the Alamo) is the most preferred alternative. However, Alternative 4 (expand to Brackenridge Park and the Missions area), Alternative 5 (expand to Brackenridge Park and to the Alamo) and Alternative 1 (expand to Brackenridge Park) are in contention. Note that all four alternatives in contention include expansion to Brackenridge Park. This fact should assure that a minimum expansion



EXPANSION ALTERNATIVES	ATTRIBUTES				
	Urban Enhancement	Economic Growth	Cost	Recreation	Social Acceptance
(1) Brackenridge Park	.5 - .6	.6 - .7	.5 - .6	.6 - .7	.8 - .9
(2) Mission Areas	.4 - .6	.25 - .35	.75 - .85	.25 - .35	.4 - .5
(3) Alamo	.15 - .3	.1 - .2	.7 - .8	.1 - .2	.1 - .2
(4) Brackenridge Park and Mission Areas	.7 - .8	.8 - .85	.2 - .3	.8 - .9	.8 - 1.
(5) Brackenridge Park and Alamo	.7 - .8	.7 - .8	.3 - .4	.7 - .8	.7 - .75
(6) Mission Areas and Alamo	.5 - .6	.45 - .55	.4 - .5	.45 - .55	.35 - .45
(7) Brackenridge Park Mission Areas and Alamo	.9 - 1.	.9 - 1.	.0 - .1	.9 - 1.	.7 - .8
(8) Don't Expand	.0 - .15	.0 - .1	.95 - 1.	.0 - .1	.0 - .1
<u>WEIGHTS</u>	.25	.33	.15	.15	.11

Fig. 6-4. Utility assessments and weights for San Antonio.

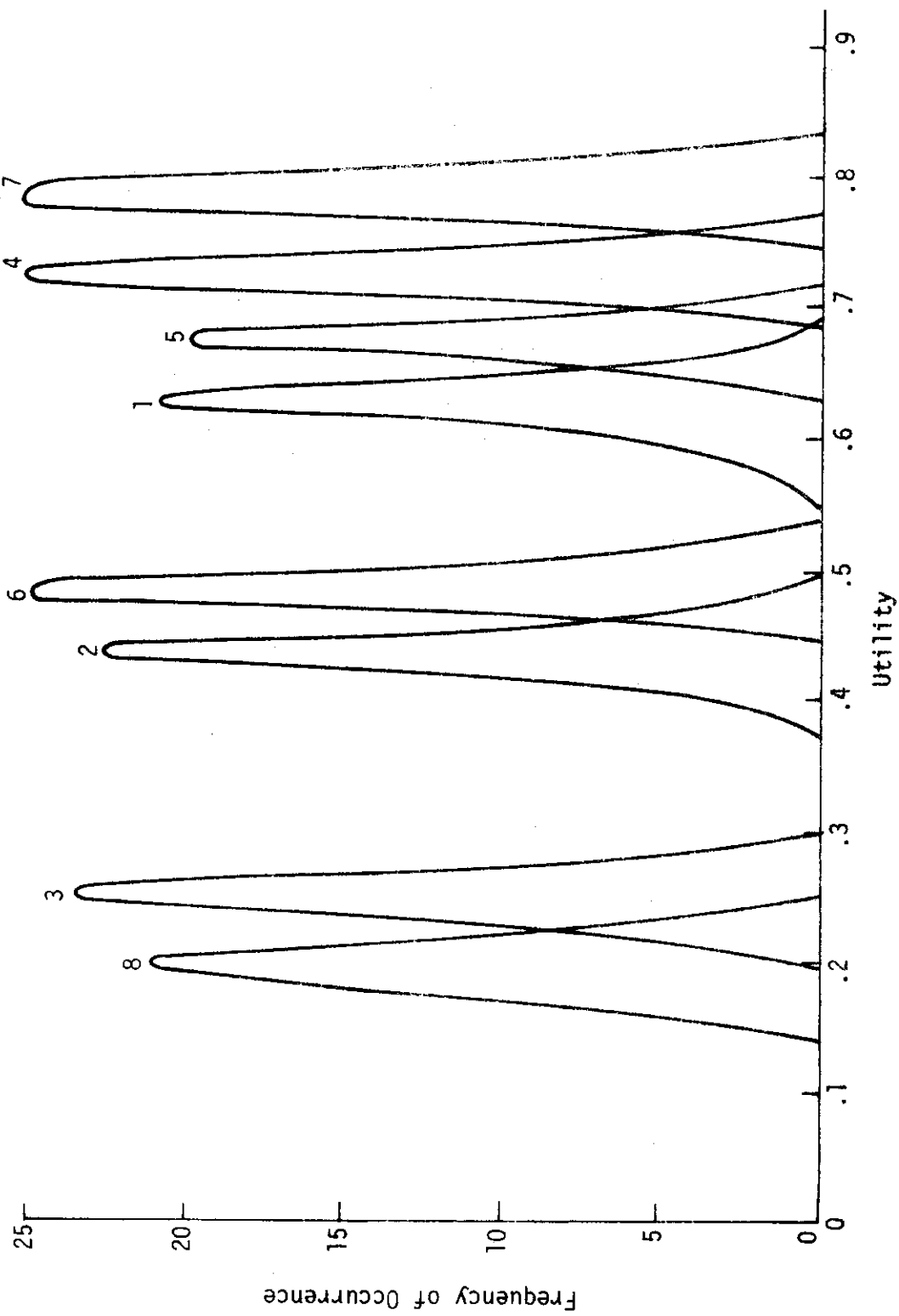

Fig. 6-5. San Antonio utility distribution graphs.

of the River Walk should include a northward extension to  
Brackenridge Park.

## CHAPTER 7

### CONCLUSIONS AND RECOMMENDATIONS

This project has taken the techniques of decision analysis and recent developments in multiattribute utility theory, combined and applied them to practical problems in the field of urban water resources development.

#### Discussion of Results

Decision analysis techniques are enhanced if they are applied by a decision analyst who has a wealth of knowledge in the decision problem field. However, since the attribute and alternative selections and the utility and probability assessments are made by experts knowledgeable of the problem and the problem area in general; it is sufficient for the analyst to have only an adequate knowledge of the decision problem yield. Specifically, the decision analyst should be able to aid the decision maker to avoid pitfalls in his subjective evaluations.

The application of decision analysis techniques is especially appropriate to problems embedded with perceptive confusion. When a decision maker does not have a clear idea of his relative preferences among his decision alternatives, he will readily accept the assistance offered by a decision analyst. When the decision problem has only one attribute it may be easy for a decision maker to keep track of his relative preferences among many alternatives. But, as the

number of attributes increased, the perceptive confusion of a decision maker will increase exponentially.

Another aspect of decision analysis that enhances its application potential is that decision analysis techniques offer an explicit medium of communication among a group of decision makers. When words are used as the sole communications medium to express individual preferences, the definitions of the words tend to be flavored by the emotional feelings of the speaker and the listener. However, when utility numbers are used to express preferences, communication between decision makers is very precise. For this reason, when a decision problem is to be solved by a group of decision makers, the group consensus may be expedited and strengthened with the use of decision analysis techniques.

An additional enhancement of decision analysis techniques for group decision-making problems is that the person in charge of the group may, if he desires, weight each group member's knowledge of the problem relative to the knowledge of others in the group. Assessing the weights for individuals is analogous to assessing the weights for the attributes.

The systems planning approach for urban water resources development described in Chapter 4 will assist urban water resources planners and decision makers properly develop the water resources systems under their control. The detailed procedures specified in the total systems approach can only aid the efforts of the people involved in the effective development and utilization of water resources.

The general decision analysis model used for the solution of the decision problems in San Angelo and San Antonio involved the basic decision analysis techniques that were developed in Chapter 2. Further decisions will, of course, need to be made after the optimum alternatives have been selected in each problem. However, these may be made at a later date when more complete information is available. The decision analysis techniques were explained at length to offer guidelines to a person who may encounter a need for them in different decision analysis applications.

The application of decision analysis techniques in the two selected Texas cities involved little difficulty in the collection of utility data from the decision makers when the purpose of the utility data was adroitly explained. People with quantitative backgrounds tended to grasp the nature of the subjective utility assessments rather quickly. On the other hand, people with purely quantitative backgrounds tended to be initially suspicious about the purpose of these numerical judgements. The real application difficulty lies, however, in the assessment of attribute weights. Some people have an extremely difficult time trying to grasp the concept of utility independence. The particular rough spot for the decision maker was accepting the two abstract alternatives that the lottery (i.e., the lottery used to assess weights) offered. Decision makers that were experienced or had a knack for abstract thinking had no trouble making the attribute weight assessments. Most decision makers were able to make the weight assessments with additional explanation but a few completely balked.

The sensitivity analysis performed on the two case-studies adds an extra dimension of reliability to the entire decision analysis solution procedure. It assures the decision maker that slight errors in his assessments will not invalidate the optimal alternative selected due to small perturbations of the utility values.

### Conclusions

The specific conclusions of this research are:

1. Decision analysis techniques are very appropriate for decision problems having multiattributed consequences.
2. Decision analysis techniques offer an explicit medium of communication among decision makers.
3. The systems planning approach developed in Chapter 4 is a valuable guide for water resources development decision problems and in other decision making areas as well.
4. The decision analyst should exercise caution in selecting individuals to assess weights for the attributes.
5. A sensitivity analysis adds an extra measure of confidence to the decision analysis techniques.

## REFERENCES

1. Robert H. Boyle, John Graves and T. H. Watkins, *The Water Hustlers*, Sierra Club, San Francisco, 18-134 (1971).
2. P. C. Fishburn, "Interdependence and Additivity in Multivariate, Unidimensional Expected Utility Theory," *International Economic Review* 8, 335-342 (1967).
3. \_\_\_\_\_, "Additive Utilities with Finite Sets; Application in Management Sciences," *Naval Research Logistics Quarterly* 14, 1-13 (1967).
4. Peter C. Fishburn, *Utility Theory for Decision Making*, John Wiley & Sons, Inc., New York (1970).
5. Freeze, Nichols & Endress, Consulting Engineers, "Water Supply Plan: 1970-2000," Report to Concho Valley Council of Governments, August, 1970.
6. \_\_\_\_\_, "Report on Sewage and Waste Collection, Sewage Treatment, Related Water Quality for Tom Green County," 1970.
7. J. E. Freund, *Mathematical Statistics*, Second Edition, Prentice-Hall Inc., Englewood Cliffs, New Jersey, 146-149 (1971).
8. Joseph R. Garner and C. S. Shih, "Identification of Management and Planning Problems of Urban Water Resources in the Metropolitan Area of Greater San Antonio," Water Resources Institute TR-39, Texas A&M University, September 1971.
9. Robert Gladstone & Associates, Economic Consultants, "Growth and Development Potential for Tom Green County, Texas," 1969.
10. E. F. Gloyna et al. (ed.) "Advances in Water Quality Improvement," University of Texas Press, Austin and London, 1968.
11. Earnest F. Gloyna and William S. Butcher, *Conflicts in Water Resources Planning*, Bill Clayton's article "The Urgency of Standardized Governmental Policy for Water Resource Development," Center for Research in Water Resources, Austin, Texas, 156-161 (1972).



12. Clare A. Gunn, David J. Reed and Robert E. Couch, "Cultural Benefits from Metropolitan River Recreation--San Antonio Prototype, Texas Water Resources Institute, TR-43, Texas A&M University, June 1972.
13. Warren A. Hall and John A. Dracup, *Water Resources Systems Engineering*, McGraw-Hill, New York, 39-115 (1970).
14. Kennety K. Hekimian and Frank R. Bowerman, "A Decision Theory Approach to Solid Waste Management System Selection," paper presented to the American Public Works Association Congress, Philadelphia, Penn., September 1971.
15. Jack Hirshleifer, James C. DeHaven and Jerome W. Milliman, *Water Supply*, University of Chicago Press, Chicago, 1960.
16. Ralph L. Keeney, "Multidimensional Utility Functions: Theory Assessment and Application," Technical Report No. 43, Operations Research Center, MIT, 1969.
17. \_\_\_\_\_, "Multiplicative Utility Functions," Technical Report No. 70, Operations Research Center, MIT, 1972.
18. Edward Kuiper, *Water Resources Development*, Butterworth & Co. London, 1965.
19. Arther Maas et al., *Design of Water Resource Systems*, Harvard University Press, Cambridge, Mass., 1966.
20. National Academy of Sciences, "Technology: Process of Assessment and Choice," July, 1969.
21. J. von Neumann and O. Morgenstern, *Theory of Games and Economic Behavior*, 2nd Ed., Princeton University Press, Princeton, N.J. (1947).
22. Gary E. O'Connor, "A Managed Atmospheric Water Resource Model," Meterology Department, Texas A&M University, November 1971.
23. R. A. Pollack, "Additive Von Neumann-Morgenstern Utility Functions," *Econometrica* 35, 485-494 (1967).
24. John W. Pratt, Howard Raiffa and Robert O. Schlaifer, *Introduction to Statistical Decision Theory*, McGraw-Hill, New York, 1965.

25. Howard Raiffa, "Preferences for Multi-Attributed Alternatives," RM-5868-DOT/RC, the Rand Corporation, April 1969.
26. \_\_\_\_\_, *Decision Analysis*, Addison-Wesley, Reading, Mass., 1970.
27. Anthony Ralston, *A First Course in Numerical Analysis*, McGraw-Hill, New York, 1965.
28. R. O. Schlaifer, *Probability and Statistics for Business Decisions*, McGraw-Hill, New York, 1959.
29. \_\_\_\_\_, *Analysis of Decisions Under Uncertainty*, McGraw-Hill, New York, 1967.
30. C. S. Shih, "Preliminary Identification for the Urban Water Development Problems in San Angelo," Final Report to Concho Valley Council of Governments, Water Resources Institute, Texas A&M University, December 1970.
31. \_\_\_\_\_, Classroom Notes from I.E. 627, Spring 1972.
32. Southwest Research Institute, "A Study of Costs for Reusing Municipal Waste Return Flows in Selected Texas Cities," Vol. 5, October 1971.
33. \_\_\_\_\_, "A Study of Costs for Reusing Municipal Waste Return Flows in Selected Texas Cities," Vol. 6, October 1971.
34. Texas Water Development Board, "Reconnaissance Investigation of the Ground Water Resources of the Colorado River Basin, Texas," Report 51, 1967.
35. \_\_\_\_\_, Interoffice Memorandum to R. C. Peckham, July 16, 1970.
36. \_\_\_\_\_, Interoffice Memorandum to R. C. Peckham, July 21, 1970.
37. Water Resources Seminar, Lyndon B. Johnson School of Public Affairs, "A Study of Development and Management of Water Resources in the Area Surrounding the Edwards Aquifer," Unpublished report, University of Texas, Austin, Texas, May 1971.
38. Stephan Young, "A Water Development Program for America's Future," in a speech to the National Waterways Conference, Washington, D.C., 1969.

## APPENDIX I

## BAYES' THEOREM

If  $B_1, B_2, \dots, B_k$  are a set of mutually exclusive events of which one must occur and none has zero probability, then for any event  $A$ , such that  $P(A) \neq 0$ , then

$$P(B_r|A) = \frac{P(B_r) \cdot P(A|B_r)}{\sum_{i=1}^k P(B_i) \cdot P(A|B_i)}, \quad r = 1, 2, \dots, k.$$

Lemma 1: If  $B_1, B_2, \dots, B_k$  are mutually exclusive events of which one must occur and none has zero probability, then for any event  $A$  such that  $P(A) \neq 0$ ,

$$P(A) = \sum_{i=1}^k P(B_i) \cdot P(A|B_i).$$

Proof of Lemma 1: It follows from the given information that

$$A = (A \cap B_1) \cup (A \cap B_2) \cup \dots \cup (A \cap B_k).$$

$$\text{Hence } P(A) = P(A \cap B_1) + P(A \cap B_2) + \dots + P(A \cap B_k)$$

$$\text{and } P(A) = P(B_1) \cdot P(A|B_1) + P(B_2) \cdot P(A|B_2) + \dots + P(B_r) \cdot P(A|B_k)$$

$$= \sum_{i=1}^k P(B_i) \cdot P(A|B_i).$$

Thus Lemma 1 is established.

Since  $P(B_r) \cdot P(A|B_r) = P(A \cap B_r)$

and  $\sum_{i=1}^k P(B_i) \cdot P(A|B_i) = P(A)$  by Lemma 1,

it is apparent that

$$\frac{P(A \cap B_r)}{P(A)} = P(B_r|A).$$

Hence, Bayes' Theorem has been proven.

## APPENDIX II

## KEENEY'S MULTIPLICATIVE UTILITY THEOREM

Let  $X \equiv X_1 \times X_2 \times \dots \times X_n$ ,  $n \geq 3$ . If for some  $i$ ,  $X_i \times X_j$  is preferentially independent of  $X_{\overline{ij}}$ ,  $j \neq i$ ,  $i = 1, \dots, n$ ,  $j = 1, 2, \dots, n$  and if  $X_i$  is utility independent of  $X_{\overline{i}}$ , then either

$$u(\underline{x}) = \sum_{r=1}^n k_r u_r(x_r) \quad (\text{A2-1})$$

or

$$1 + k u(\underline{x}) = \prod_{r=1}^n [1 + k k_r u_r(x_r)], \quad (\text{A2-2})$$

where  $u$  and  $u_r$  are utility functions scaled from zero to one,  $r = 1, 2, \dots, n$ , the  $k_r$  are scaling constants with  $0 < k_r < 1$ , and  $k$  is a scalar.

Proof: The proof of this theorem closely follows the proof found in Keeney.<sup>[17]</sup> This theorem is more tractable when broken into three lemmas which can be interlaced together. For notational convenience, when an attribute is at its least desirable amount, designated as  $x_i^0$ , for example, it will be deleted from the function when no ambiguity will result. Thus rather than write  $u(x_i^0, x_j^0, x_k^0, x_{\overline{ijk}})$ ,  $u(x_{\overline{ijk}})$  will be used.

Lemma 1: If  $X_i$  is utility independent of  $X_{\overline{i}}$  and if  $X_i \times X_j$  is preferentially independent of  $X_{\overline{ij}}$ , then  $X_i \times X_j$  is

utility independent of  $X_{\bar{ij}}$ .

Proof of Lemma 1: The condition that  $X_i$  is utility independent of  $X_{\bar{j}}$  may be written mathematically as

$$u(x_i, x_j, x_{\bar{ij}}) = u(x_j, x_{\bar{ij}}) + b(x_j, x_{\bar{ij}}) u(x_i). \quad (\text{A2-3})$$

Since  $X_i \times X_j$  is preferentially independent of  $X_{\bar{ij}}$ , we know that if

$$u(x_i, x_j, x_{\bar{ij}}^o) = u(x_i^t, x_j^t, x_{\bar{ij}}^o)$$

then

$$u(x_i, x_j, x_{\bar{ij}}) = u(x_i^t, x_j^t, x_{\bar{ij}}) \quad (\text{A2-4})$$

for all  $x_{\bar{ij}}$ .

Choose  $x_i^t$  such that

$$u(x_i, x_j, x_{\bar{ij}}^o) = u(x_i^t, x_j^o, x_{\bar{ij}}^o). \quad (\text{A2-5})$$

Then by substituting (A2-3) into (A2-5) with  $x_{\bar{ij}} = x_{\bar{ij}}^o$

$$u(x_j) + b(x_j) u(x_i) = u(x_i^t). \quad (\text{A2-6})$$

By (A2-5) and the assumption of preferential independence,

$$u(x_i, x_j, x_{\bar{ij}}) = u(x_i^t, x_j^o, x_{\bar{ij}}) \quad (\text{A2-7})$$

for all  $x_{\bar{ij}}$ .

After evaluating both sides of (A2-7) with (A2-3) and combining the results with (A2-6)

$$\begin{aligned} u(x_j, x_{\overline{ij}}) + b(x_j, x_{\overline{ij}}) u(x_i) \\ = u(x_{\overline{ij}}) + b(x_{\overline{ij}})[u(x_j) + b(x_j) u(x_i)]. \end{aligned} \quad (\text{A2-8})$$

Let  $x_i = x_i^0$  in (A2-8) and

$$u(x_j, x_{\overline{ij}}) = u(x_{\overline{ij}}) + b(x_{\overline{ij}}) u(x_j) \quad (\text{A2-9})$$

which can be substituted back into (A2-8) to yield

$$b(x_j, x_{\overline{ij}}) = b(x_j) b(x_{\overline{ij}}). \quad (\text{A2-10})$$

Now by substituting (A2-9) and (A2-10) into (A2-3),

$$\begin{aligned} u(x_i, x_j, x_{\overline{ij}}) \\ = u(x_{\overline{ij}}) + b(x_{\overline{ij}}) u(x_j) + b(x_j) b(x_{\overline{ij}}) u(x_i) \\ = u(x_{\overline{ij}}) + b(x_{\overline{ij}})[u(x_j) + b(x_j) u(x_i)] \\ = u(x_{ij}) + b(x_{ij}) u(x_i, x_j). \end{aligned} \quad (\text{A2-11})$$

Equation (A2-11) is the desired mathematical statement that  $X_{ij}$  is utility independent of  $X_{\overline{ij}}$ .

Lemma 2: If  $X_i \times X_j$  is utility independent of  $X_{\overline{ij}}$  and  $X_i \times X_k$  is utility independent of  $X_{\overline{ik}}$  then  $X_i \times X_j \times X_k$  is utility independent of  $X_{\overline{ijk}}$ .

Proof of Lemma 2: By the given utility independence conditions,

$$\begin{aligned} u(x_i, x_j, x_k, x_{\overline{ijk}}) \\ = u(x_k, x_{\overline{ijk}}) + a(x_k, x_{\overline{ijk}}) u(x_i, x_j) \end{aligned} \quad (\text{A2-12})$$

and

$$\begin{aligned} u(x_i, x_j, x_k, x_{\overline{ijk}}) \\ = u(x_j, x_{\overline{ijk}}) + b(x_j, x_{\overline{ijk}}) u(x_i, x_k). \end{aligned} \quad (\text{A2-13})$$

Let  $x_i = x_i^0$ ,  $x_j = x_j^0$ ,  $x_k = x_k^0$ ,  $x_{\overline{ijk}} = x_{\overline{ijk}}^0$  as appropriate in (A2-13) and substitute (A2-13) into (A2-12) to obtain

$$\begin{aligned} u(x_i, x_j, x_k, x_{\overline{ijk}}) = u(x_{\overline{ijk}}) + b(x_{\overline{ijk}}) u(x_k) + a(x_k, x_{\overline{ijk}}) \\ \cdot [u(x_j) + b(x_j) u(x_i)]. \end{aligned} \quad (\text{A2-14})$$

Now with necessary substitutions in (A2-12), substitute (A2-12) into (A2-13) to obtain

$$\begin{aligned} u(x_i, x_j, x_k, x_{\overline{ijk}}) \\ = u(x_{\overline{ijk}}) + a(x_{\overline{ijk}}) u(x_j) \\ + b(x_j, x_{\overline{ijk}})[u(x_k) + a(x_k) u(x_i)]. \end{aligned} \quad (\text{A2-15})$$

The result of equating (A2-14) with (A2-15) when  $x_j = x_j^0$  is



$$a(x_k, x_{\overline{ijk}}) = b(x_{\overline{ijk}}) a(x_k). \quad (\text{A2-16})$$

Note that  $b(x_j) = 1$  by (A2-13). Finally substitute (A2-16) into (A2-14) using (A2-13) to obtain

$$\begin{aligned} u(x_i, x_j, x_k, x_{\overline{ijk}}) & \\ &= u(x_{\overline{ijk}}) + b(x_{\overline{ijk}})[u(x_k) + a(x_k) u(x_i, x_j)] \\ &= u(x_{\overline{ijk}}) + b(x_{\overline{ijk}}) u(x_i, x_j, x_k) \end{aligned}$$

with the aid of (A2-12). Hence  $X_i \times X_j \times X_k$  is utility independent of  $X_{\overline{ijk}}$ .

Lemma 3: If  $X_{\overline{i}}$  is utility independent of  $X_i$  then either (A2-1) or (A2-2) is true.

Proof of Lemma 3: We may assume without loss of generality that  $X_{\overline{i}}$  is utility independent of  $X_i$  for  $i = 1, 2, \dots, n - 1$  which implies

$$u(\underline{x}) = u(x_i) + c_i(x_i) u(x_{\overline{i}}), \quad i = 1, 2, \dots, n - 1. \quad (\text{A2-17})$$

When all  $x_i = x_i^0$  except  $x_1$  and  $x_j$ , for  $j = 2, 3, \dots, n - 1$ ,

$$\begin{aligned} u(x_1, x_j) &= u(x_1) + c_1(x_1) u(x_j) \\ &= u(x_j) + c_j(x_j) u(x_1). \end{aligned}$$

It follows that

$$\frac{c_j(x_j) - 1}{u(x_j)} = \frac{c_1(x_1) - 1}{u(x_1)} = k. \quad (\text{A2-18})$$

$$\text{Thus } c_i(x_i) = k u(x_i) + 1 \text{ for } i = 1, 2, \dots, n - 1. \quad (\text{A2-19})$$

By the repeated use of (A2-17),

$$\begin{aligned} u(\underline{x}) &= u(x_1) + c_1(x_1) u(x_2, \dots, x_n) \\ &= u(x_1) + c_1(x_1) [u(x_2) + c_2(x_2) u(x_3, \dots, x_n)] \\ &\quad \cdot \\ &\quad \cdot \\ &= u(x_1) + c_1(x_1) u(x_2) + c_1(x_1) c_2(x_2) u(x_3) + \dots + \\ &\quad c_1(x_1) \cdots c_{n-1}(x_{n-1}) u(x_n). \end{aligned} \quad (\text{A2-20})$$

Substituting (A2-19) into (A2-20) yields

$$\begin{aligned} u(\underline{x}) &= u(x_1) + [k u(x_1) + 1] u(x_2) + [k u(x_1) + 1] \\ &\quad \cdot [k u(x_2) + 1] u(x_3) + \dots + \\ &\quad [k u(x_1) + 1][k u(x_2) + 1] \cdots \\ &\quad [k u(x_{n-1}) + 1] u(x_n). \end{aligned} \quad (\text{A2-21})$$

When  $k = 0$ , (A2-21) becomes the additive utility function

$$u(\underline{x}) = \sum_{i=1}^n u(x_i). \quad (\text{A2-22})$$

When  $k \neq 0$ , multiply both sides of (A2-21) by  $k$  and add 1 to

both sides to obtain

$$k u(\underline{x}) + 1 = \prod_{i=1}^n [k u(x_i) + 1]. \quad (\text{A2-23})$$

Define  $u(x_i) = k_i u_k(x_i)$  so the  $u_i(x_i)$  can have the range of  $[0, 1]$  and (A2-22) and (A2-23) may be rewritten as

$$u(\underline{x}) = \sum_{i=1}^n k_i u_i(x_i) \quad (\text{A2-1})$$

and

$$k u(\underline{x}) + 1 = \prod_{i=1}^n [k k_i u_i(x_i) + 1], \quad (\text{A2-2})$$

which proves Lemma 3.

Now that the three Lemmas have been proven the Multiplicative Utility Theorem may be proven. The proof for  $n = 3$  is evident with the application of Lemmas 1 and 3. The proof for  $n \geq 4$  is as follows. Given the assumptions as stated in the theorem, it follows from Lemma 1 that  $X_i \times X_j$  is utility independent of  $X_{\overline{ij}}$  for all  $j \neq i$ . By the repeated use of Lemma 2 it may be seen that when overlapping sets of attributes are utility independent of their complementary sets, their union is utility independent of its complement. Thus  $X_{\overline{j}}$  is utility independent of  $X_j$  for all  $j \neq i$ . The additive or multiplicative form of the utility function follows from Lemma 3.

## APPENDIX III

## A SENSITIVITY ANALYSIS PROGRAM

This program computes utilities for non-sequential decision alternatives and outputs a graph of the utility distributions. The program was dimensioned to handle a maximum of 10 decision alternatives and 10 attributes. This program was written by Joe H. Dean at Texas A&M University in May of 1973. The machine used is an IBM 360 Model 65. The language used is WATFIV.

## Input Data Required

The first input card contains the number of alternatives (NUMALT), the number of attributes (NUMATT), the number of calculations desired per alternative (NCALPA) and the number of attributes with CDF data. This first card is read with a 4 I 3 format.

The ranges of the attributes are read next. They are read in left to right fashion. The left end point and right end point are read sequentially for all the attributes of each alternative. The format used is 7 F 10.2.

The weights for each attribute are read next with a 7 F 10.2 format.

The CDF data is read next. These points correspond in order to the following probability assessment points: .0, .25, .5, .75 and 1. The five corresponding CDF points are read for all attributes of each alternative in a 7 F 10.2 format.

Utility curve data is the last input. The utility assessment points correspond to utilities of .0, .25, .5, .75 and 1. The corresponding utility assessments are read in for each attribute with CDF data with a 7 F 10.2 format.

#### Description of Logic

This program fits a cubic equation to the CDF data and a quadratic equation to the decreasing risk adverse utility data. Random utility values for the attributes of each alternative are computed in one of two ways. If the attribute was assessed with CDF data, the procedure is to generate a random number, convert this to a random attribute value by using the cubic equation, then convert this random attribute value to a random utility value by using the quadratic equation. Random utility values for attributes without CDF data are linearly transformed from 0-1 to the attribute ranges.

The additive multiattribute utility function is used to calculate the utility of each alternative. Care should be taken to scale the attribute weights so that they add to 1.

#### Program Output

A utility distribution graph will be printed for each decision alternative. It is suggested that 100 to 200 calculations per alternative be tried on the initial run. The frequency of occurrence axis (y-axis) of the output graph has a fixed range of

0 to 30 and an excess of 200 calculations per alternative may not give the desired output. The maximum y-axis value can be written as a function of the number of calculations per alternative so that the y-axis can "float." However, the functional relationship will be highly dependent on the widths of the attribute ranges.

Program Listing

```

//SOPTIONS
  DIMENSION CDF(10,3,5),X(5),Y(5),ATTBTE(10,10,2),
*UTILITY(10),U(10,10),CUBCDF(10,3),UTCURV(10,5),
*UTQUAD(10,2),OUTMAT(35,80),WEIGHT(10),NFREQ(80),
*WT(10),A(5)
  DATA AXIS, POINT,BLANK/'X','*',', ' /
  RNO=.1234

C
C INPUT DATA
C
  READ(5,1 )NUMALT,NUMATT,NCALPA,NACDFD
1  FORMAT(4I3)
  DO 2  I=1,NUMALT
C
C READ RANGES OF ATTRIBUTES FOR EACH ALTERNATIVE.
C
2  READ(5,3 )((ATTBTE(I,J,K),K=1,2),J=1,NUMATT)
3  FORMAT(7F10.2)
C
C READ WEIGHTS FOR EACH ATTRIBUTE
C
  READ(5,3 ) (WEIGHT(I) ,I=1,NUMATT)
  IF(NACDFD.EQ.0)GO TO 5
  DO 4  I=1,NUMALT
C
C READ CDF DATA
C
4  READ(5,3 )((CDF(I,J,K),K=1,5),J=1,3)
C
C READ UTILITY CURVE DATA
C
  READ(5,3 )((UTCURV(J,K),K=1,5),J=1,3)
5  CONTINUE
  WRITE(6,6 )
6  FORMAT('1')
C
C OUTPUT THE INPUT INFORMATION
C
  PRINT,'NUMALT'
  WRITE(6,7 )NUMALT,NUMATT,NCALPA,NACDFD
7  FORMAT(4I4)
  PRINT,'ATTRIBUTE DATA'
  DO 8  I=1,NUMALT
8  WRITE(6,9 )((ATTBTE(I,J,K),K=1,2),J=1,NUMATT)
9  FORMAT(7 F10.2)
  PRINT,'WEIGHTS'
  WRITE(6,9 ) (WEIGHT(I),I=1,NUMATT)

```



```

        IF (NACDFD.EQ.0)GO TO 11
        PRINT,'CDF DATA'
        DO 10 I=1,NUMALT
10     WRITE(6,9 )((CDF(I,J,K),K=1,5),J=1,3)
        PRINT,'UTILITY CURVE DATA'
        WRITE(6,9 )((UTCURV(J,K),K=1,5),J=1,3)
11     CONTINUE
C
C     SETUP AXIS FOR OUTPUT GRAPH
C
        DO 12 I=1,35
12     OUTMAT(I,1)=AXIS
        DO 13 I=2,80
13     OUTMAT(35,I)=AXIS
        IF (NACDFD.EQ.0)GO TO 18
        X(1)=0.0
        X(2)=.25
        X(3)=.5
        X(4)=.75
        X(5)=1.
C
C     LINEARLY TRANSFORM THE UTILITY DATA TO THE INTERVAL
C     0 TO 1.
C
        DO 15 J=1,NACDFD
        DENOM=ABS(UTCURV(J,1)-UTCURV(J,5))
        DO 14 I=2,4
14     UTCURV(J,I)=ABS(UTCURV(J,I)-UTCURV(J,1))/DENOM
        UTCURV(J,1)=0.0
        UTCURV(J,5)=1.0
15     CONTINUE
C
C     FIT A QUADRATIC EQUATION TO THE UTILITY DATA.
C
        DO 17 J=1,NACDFD
        DO 16 I=1,5
16     Y(I)=UTCURV(J,I)
        CALL UTFIT(X,Y,A)
        UTQUAD(J,1)=A(1)
17     UTQUAD(J,2)=A(2)
18     CONTINUE
        DO 34 ITER=1,NUMALT
        IF (NACDFD.EQ.0)GO TO 23
C
C     LINEARLY TRANSFORM THE CDF DATA TO THE ENTerval 0 TO
C     1.
C
        DO 22 J=1,NACDFD

```

```

DENOM=ABS(CDF(ITER,J,1)-CDF(ITER,J,5))
DO 19 I=2,4
19 CDF(ITER,J,I)=ABS(CDF(ITER,J,I)-CDF(ITER,J,1))/
    *DENOM
    CDF(ITER,J,1)=0.0
    CDF(ITER,J,5)=1.0
C
C FIT THE CDF DATA WITH A CUBIC EQUATION.
C
    DO 20 I=1,5
20 Y(I)=CDF(ITER,J,I)
    CALL CUBFIT(X,Y,A)
    DO 21 I=1,3
21 CUBCDF(J,I)=A(I)
22 CONTINUE
23 CONTINUE
C
C BLANK THE OUTPUT ARRAY.
C
    DO 24 I=1,34
    DO 24 J=2,80
24 OUTMAT(I,J)=BLANK
    DO 25 I=1,80
25 NFREQ(I)=0
C
C CALCULATE THE UTILITY OF EACH ALTERNATIVE THE
C SPECIFIED NUMBER OF TIMES.
C
    DO 29 INNER=1,NCALPA
    IF(NACDFD.EQ.0)GO TO 27
    SUM=0.0
    DO 26 J=1,NACDFD
    RN=RNDNUM(RND)
    VRBL1=RN*RN*RN*CUBCDF(J,1)+RN*RN*CUBCDF(J,2)
    *+RN*CUBCDF(J,3)
    U(ITER,J)=VRBL1*VRBL1*UTQUAD(J,1)+VRBL1*UTQUAD(J,2)
    SUM=SUM+U(ITER,J)*WEIGHT(J)
26 CONTINUE
27 CONTINUE
    NPI=NACDFD+1
    IF(NACDFD.EQ.0)SUM=0.0
    DO 28 J=NPI,NUMATT
    U(ITER,J)=(ATTBTE(ITER,J,2)-ATTBTE(ITER,J,1))*
    *RNDNUM(RND)+ATTBTE(ITER,J,1)
    SUM=SUM+U(ITER,J)*WEIGHT(J)
28 CONTINUE
    UTILITY(ITER)=SUM
    IF(SUM.GE.1.)UTILITY(ITER)=.99

```

```

INDEX=UTILITY(ITER)/.0125+1.
29  NFREQ(INDEX)=NFREQ(INDEX)+1
    DO 30 J=2,80
      I=35-NFREQ(J)
      IF(I.GE.35)GO TO 30
      IF(I.LE.0)GO TO 30
      OUTMAT(I,J)=POINT
30  CONTINUE
    WRITE(6,6)
    WRITE(6,31 )ITER
31  FORMAT('0',8('/),T45,
    *THIS IS A GRAPH OF THE SENSITIVITY OF',T40,
    *ALTERNATIVE' I2'. THE ABSCISSA REPRESENTS',T40,
    *UTILITY RANGING FROM 0 TO 1 AND THE ORDINATE',T40
    *REPRESENTS FREQUENCY OF OCCURANCE RANGING',T40,
    *FROM 0 TO 30.')
    DO 32 I=6,35
32  WRITE(6,33 )(OUTMAT(I,J),J=1,80)
33  FORMAT(T28,80A1)
    WRITE(6,6)
34  CONTINUE
    STOP
    ENC

```

```

FUNCTION RNDNUM(RNO)

```

```

C
C  RNDNUM GENERATES A RANDOM NUMBER.
C

```

```

RNO=RNO*11.
I=RNO
RNO=RNO-I
RNDNUM=RNO
RETURN
END

```

```

SUBROUTINE CUBFIT(Y,X,A)

```

```

C
C  CUBFIT FITS A CUBIC TO THE CDF DATA POINTS.
C

```

```

DIMENSION Y(5),X(5),A(3),Y6(5),Y5(5),Y4(5),Y3(5),
*Y2(5),Y1(5)
PRINT,'X=',X,'Y=',Y
DO 1 I=1,5
Y1(I)=Y(I)
Y2(I)=Y1(I)*Y(I)
Y3(I)=Y2(I)*Y(I)
Y4(I)=Y3(I)*Y(I)
Y5(I)=Y4(I)*Y(I)

```

```

1   Y6(I)=Y5(I)*Y(I)
    A11=.0
    A12=.0
    A13=.0
    A21=.0
    A22=.0
    A23=.0
    DO 2 I=1,5
    A13=A13+X(I)*Y2(I)+Y6(I)-Y5(I)-X(I)*Y3(I)
    A23=A23+Y6(I)-Y4(I)+X(I)*Y(I)-X(I)*Y3(I)
    A11=A11+Y6(I)+Y4(I)-2.*Y5(I)
    A12=A12+Y6(I)-Y5(I)-Y4(I)+Y3(I)
    A21=A21+Y6(I)-Y4(I)-Y5(I)+Y3(I)
    A22=A22+Y6(I)-2.*Y4(I)+Y2(I)
2   CONTINUE
    DENOM=A11*A22-A12*A21
    A(2)=(A13*A22-A23*A12)/DENOM
    A(3)=(A11*A23-A21*A13)/DENOM
    A(1)=1.-A(2)-A(3)
    RETURN
    END

```

SUBROUTINE UTFIT(X,Y,A)

```

C
C   UTFIT FITS A QUADRATIC CURVE TO THE DECREASING
C   RISK ADVERSE UTILITY DATA.
C
    DIMENSION X(5),Y(5),A(2)
    XLEFT=0.0
    RIGHT=0.0
    DO 1 I=2,4
    XLEFT=XLEFT+X(I)*X(I)*(X(I)*X(I)-2.*X(I)+1.)
    RIGHT=RIGHT-Y(I)*X(I)*X(I)+Y(I)*X(I)+X(I)**4-X(I)**3
1   CONTINUE
    A(2)=RIGHT/XLEFT
    A(1)=1.-A(2)
    RETURN
    END

```

// \$DATA

Utility Distribution Curves for the  
San Angelo Case-Study

NUMALT	5	8	200	3			
ATTRIBUTE DATA							
350.00	400.00	350000.00	400000.00	8000.00	15000.00	0.95	0.95
1.00	0.95	1.00	0.90	1.00	0.95	1.00	1.00
0.90	1.00						
800.00	1100.00	500000.00	550000.00	8000.00	12000.00	0.00	0.00
0.10	0.95	1.00	0.40	0.50	0.50	0.60	0.60
0.40	0.50						
550.00	750.00	800000.00	1000000.00	5000.00	8000.00	0.30	0.30
0.40	0.00	0.10	0.30	0.40	0.30	0.40	0.40
0.40	0.50						
200.00	300.00	120000.00	140000.00	1800.00	2500.00	0.50	0.50
0.60	0.40	0.50	0.00	0.10	0.00	0.20	0.20
0.00	0.20						
550.00	750.00	900000.00	1100000.00	3000.00	3500.00	0.60	0.60
0.65	0.10	0.20	0.70	0.80	0.40	0.50	0.50
0.70	0.80						
WEIGHTS							
0.12	0.10	0.21	0.22	0.13	0.05	0.10	0.10
0.04							
CDF DATA							
300.00	410.00	425.00	440.00	500.00	350000.00	370000.00	
380000.00	385000.00	400000.00	8000.00	12500.00	13000.00	13500.00	
15000.00							
700.00	925.00	950.00	975.00	1200.00	500000.00	525000.00	
530000.00	535000.00	550000.00	8000.00	10500.00	10750.00	11300.00	
12000.00							
300.00	575.00	600.00	625.00	900.00	80000.00	89000.00	
90000.00	91000.00	100000.00	5000.00	6500.00	6800.00	7100.00	
8000.00							
100.00	180.00	200.00	220.00	300.00	120000.00	128000.00	
130000.00	132000.00	140000.00	1800.00	2000.00	2075.00	2150.00	
2500.00							

300.00	500.00	525.00	550.00	900.00	9000.00	9800.00
10000.00	10200.00	11000.00	3000.00	3150.00	3200.00	3250.00
3500.00						
UTILITY CURVE DATA						
1200.00	1100.00	800.00	500.00	100.00	550000.00	520000.00
420000.00	220000.00	10000.00	1800.00	2200.00	3400.00	12000.00
15000.00						

THIS IS A GRAPH OF THE SENSITIVITY OF  
ALTERNATIVE 1. THE ABSCISSA REPRESENTS  
UTILITY RANGING FROM 0 TO 1 AND THE ORDINATE  
REPRESENTS FREQUENCY OF OCCURANCE RANGING  
FROM 0 TO 30.

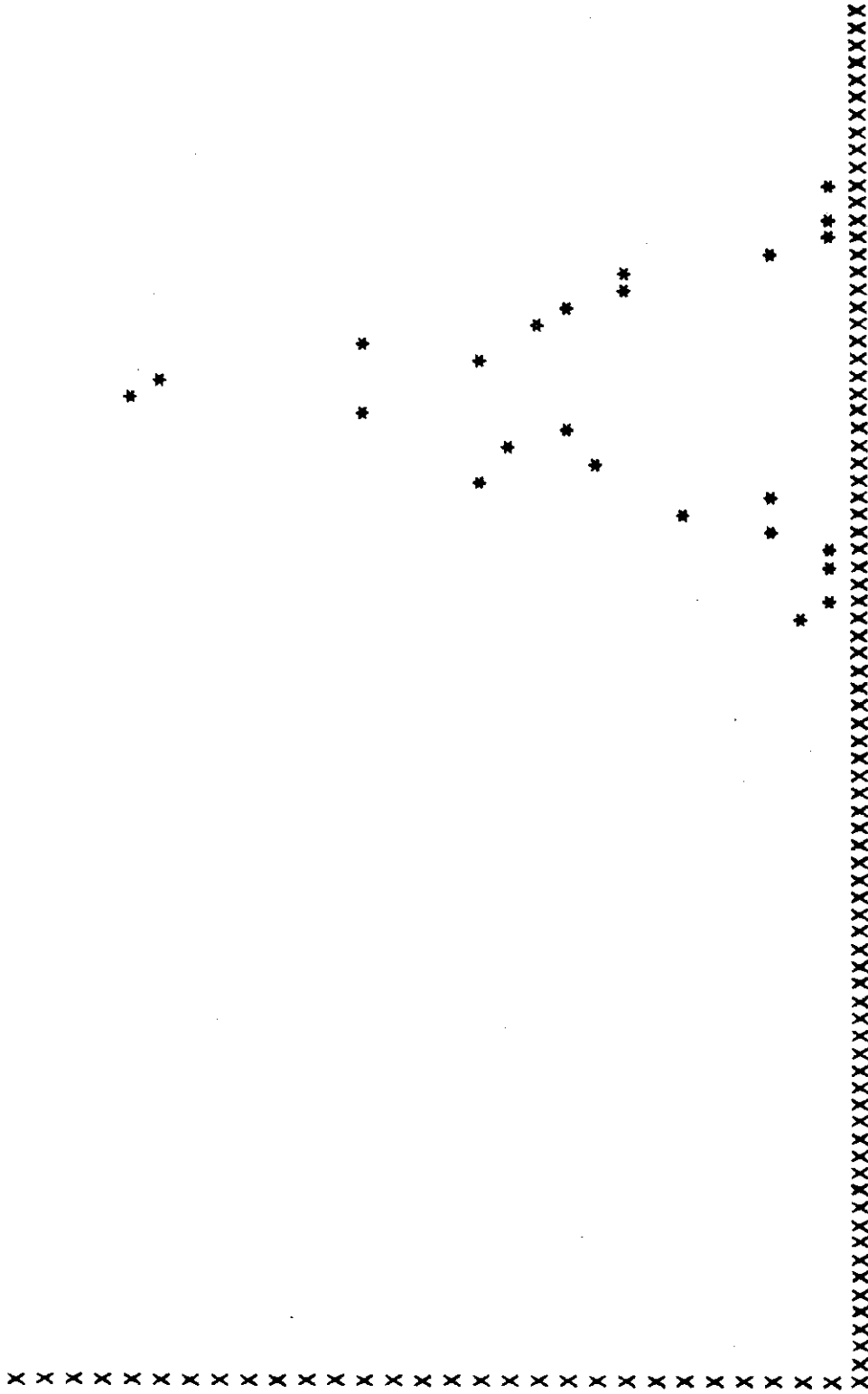



THIS IS A GRAPH OF THE SENSITIVITY OF  
ALTERNATIVE 2. THE ABSCISSA REPRESENTS  
UTILITY RANGING FROM 0 TO 1 AND THE ORDINATE  
REPRESENTS FREQUENCY OF OCCURANCE RANGING  
FROM 0 TO 30.

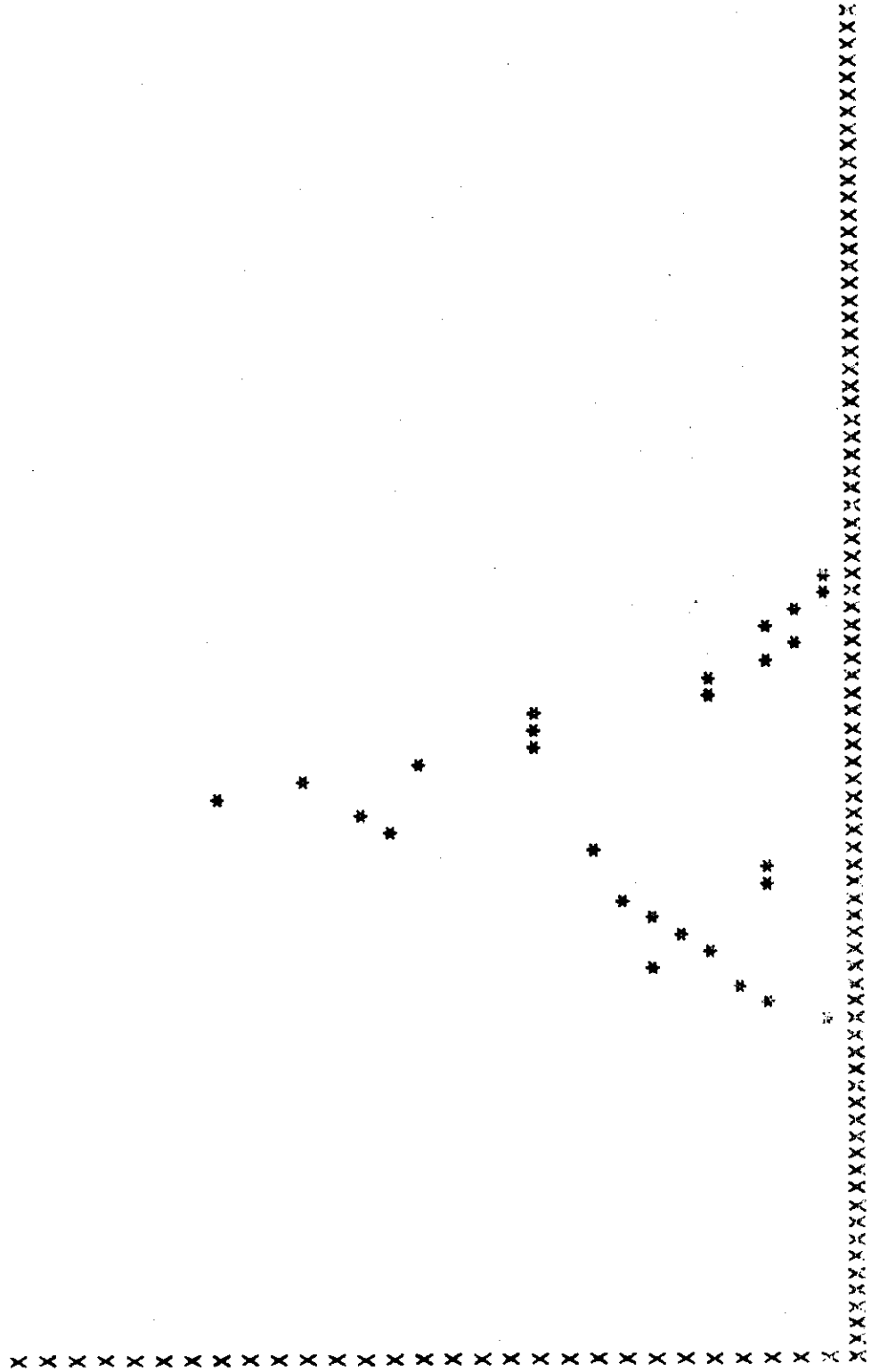

THIS IS A GRAPH OF THE SENSITIVITY OF ALTERNATIVE 3. THE ABCISSA REPRESENTS UTILITY RANGING FROM 0 TO 1 AND THE ORDINATE REPRESENTS FREQUENCY OF OCCURANCE RANGING FROM 0 TO 30.

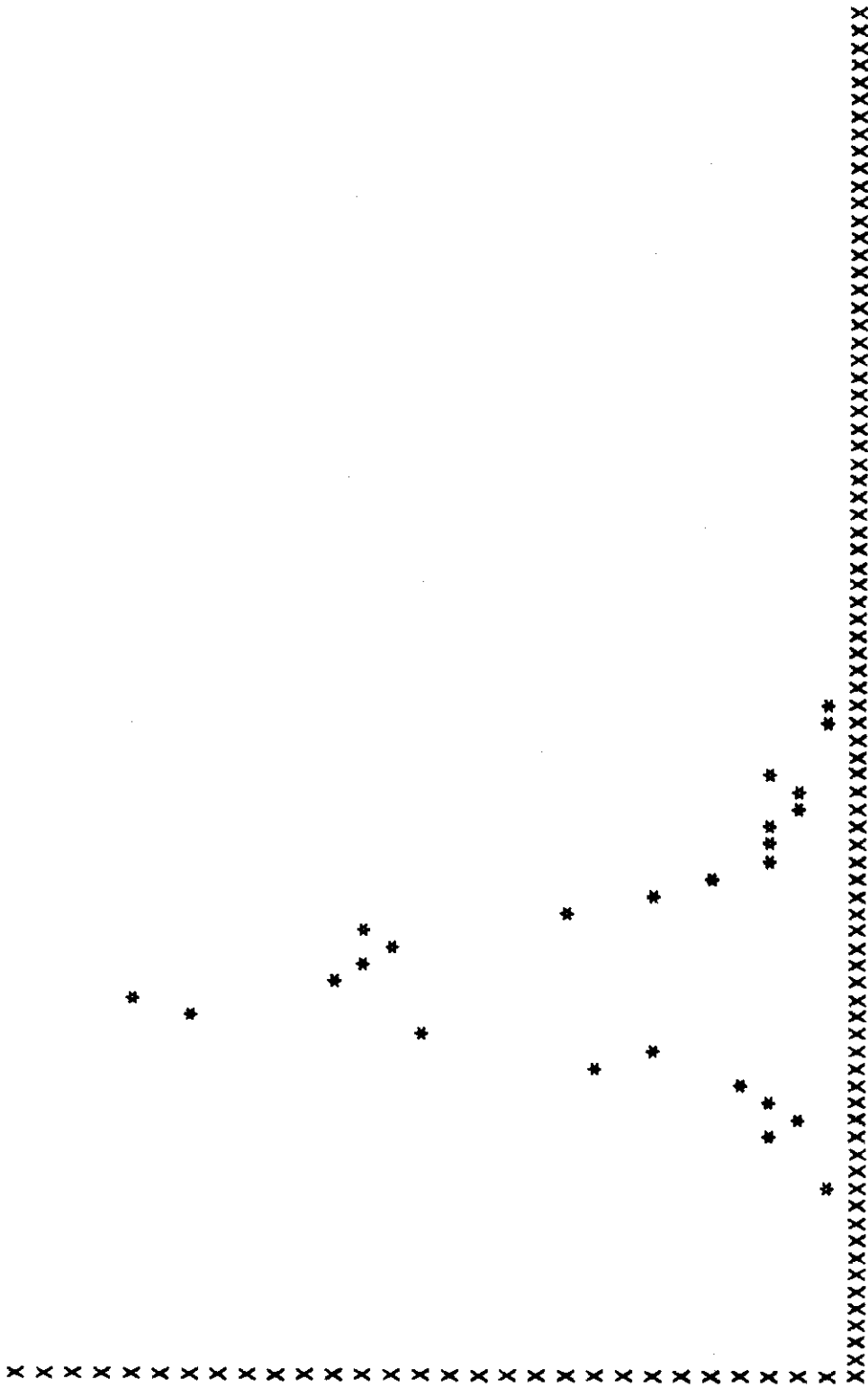

THIS IS A GRAPH OF THE SENSITIVITY OF ALTERNATIVE 4. THE ABSCISSA REPRESENTS UTILITY RANGING FROM 0 TO 1 AND THE ORDINATE REPRESENTS FREQUENCY OF OCCURANCE RANGING FROM 0 TO 30.

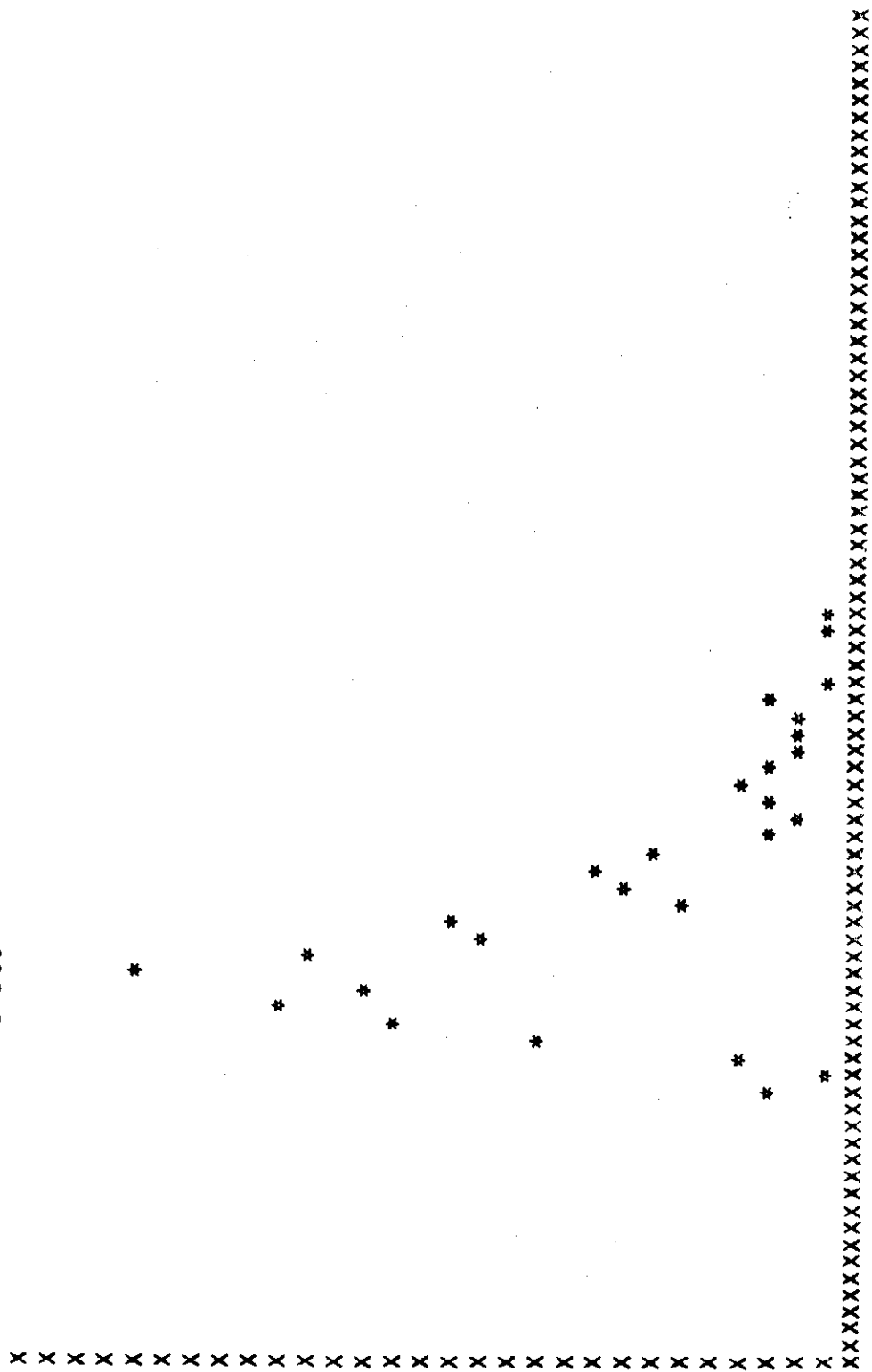

THIS IS A GRAPH OF THE SENSITIVITY OF ALTERNATIVE 5. THE ABSCISSA REPRESENTS UTILITY RANGING FROM 0 TO 1 AND THE ORDINATE REPRESENTS FREQUENCY OF OCCURANCE RANGING FROM 0 TO 30.

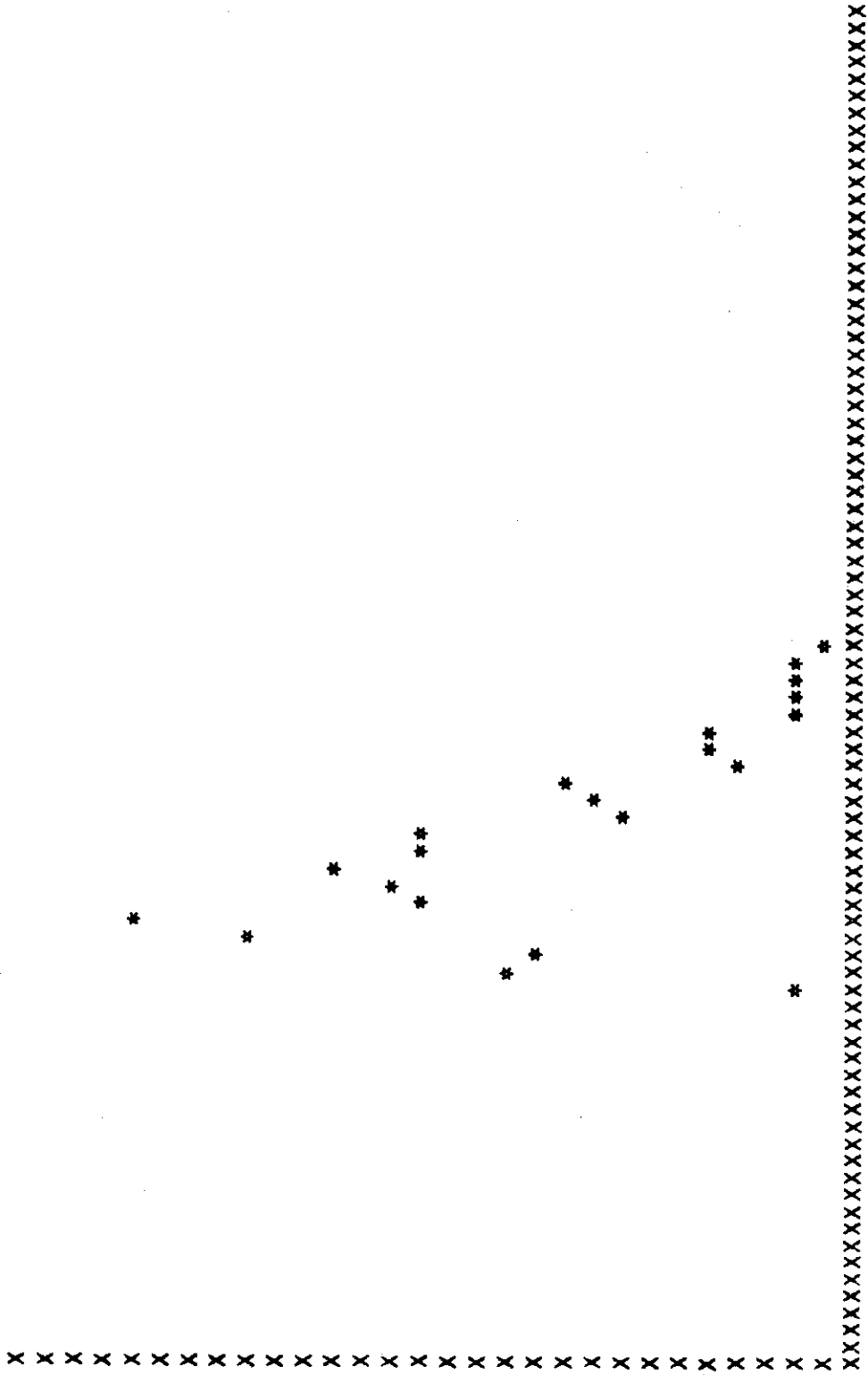

Utility Distribution Curves for the  
San Antonio Case-Study

NUMALT 8 5 100 0  
ATTRIBUTE DATA

0.50	0.60	0.60	0.70	0.50	0.60	0.60
0.70	0.80	0.90	0.35	0.75	0.85	0.25
0.40	0.60	0.25	0.20	0.70	0.80	0.10
0.35	0.40	0.50	0.85	0.20	0.30	0.80
0.15	0.30	0.10	0.80	0.30	0.40	0.70
0.20	0.10	0.20	0.85	0.40	0.50	0.45
0.70	0.80	0.80	0.70	0.00	0.10	0.90
0.90	0.80	1.00	0.80	0.95	1.00	0.00
0.70	0.80	0.70	0.80	0.10	0.10	0.10
0.80	0.70	0.75	0.55	0.40	0.50	0.45
0.50	0.60	0.45	1.00	0.00	0.10	0.90
0.55	0.35	0.45	0.10	0.95	1.00	0.00
0.90	1.00	0.90	0.10	0.15	0.00	0.10
1.00	0.70	0.80	0.15	0.00	0.10	0.10
0.00	0.15	0.00	0.00	0.11	0.15	0.33
0.10	0.00	0.10	0.15	0.11	0.15	0.33
WEIGHTS	0.25	0.33	0.15	0.11	0.15	0.33



THIS IS A GRAPH OF THE SENSITIVITY OF ALTERNATIVE 2. THE ABSCISSA REPRESENTS UTILITY RANGING FROM 0 TO 1 AND THE ORDINATE REPRESENTS FREQUENCY OF OCCURANCE RANGING FROM 0 TO 30.

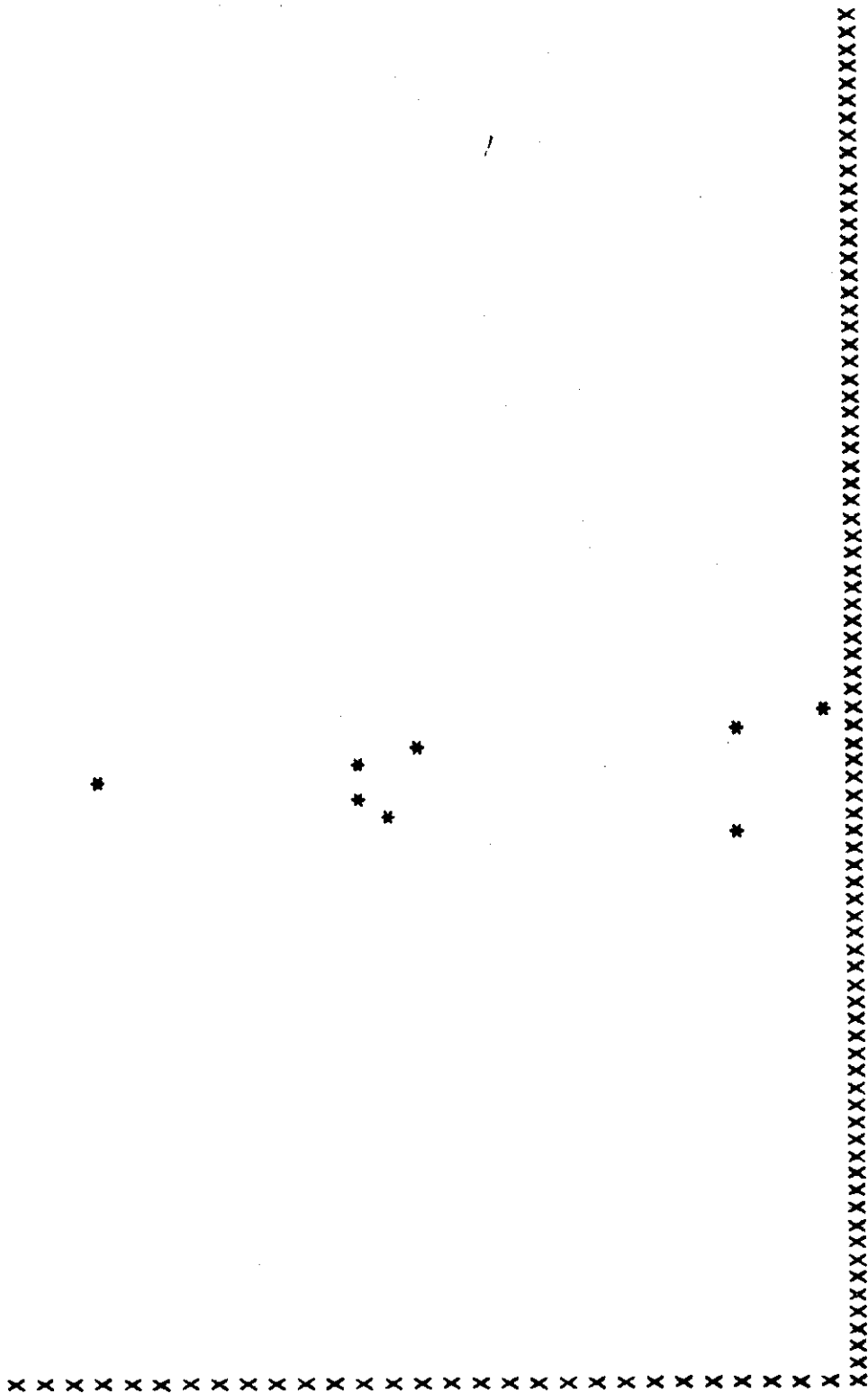



THIS IS A GRAPH OF THE SENSITIVITY OF  
 ALTERNATIVE 3. THE ABSCISSA REPRESENTS  
 UTILITY RANGING FROM 0 TO 1 AND THE ORDINATE  
 REPRESENTS FREQUENCY OF OCCURANCE RANGING  
 FROM 0 TO 30.

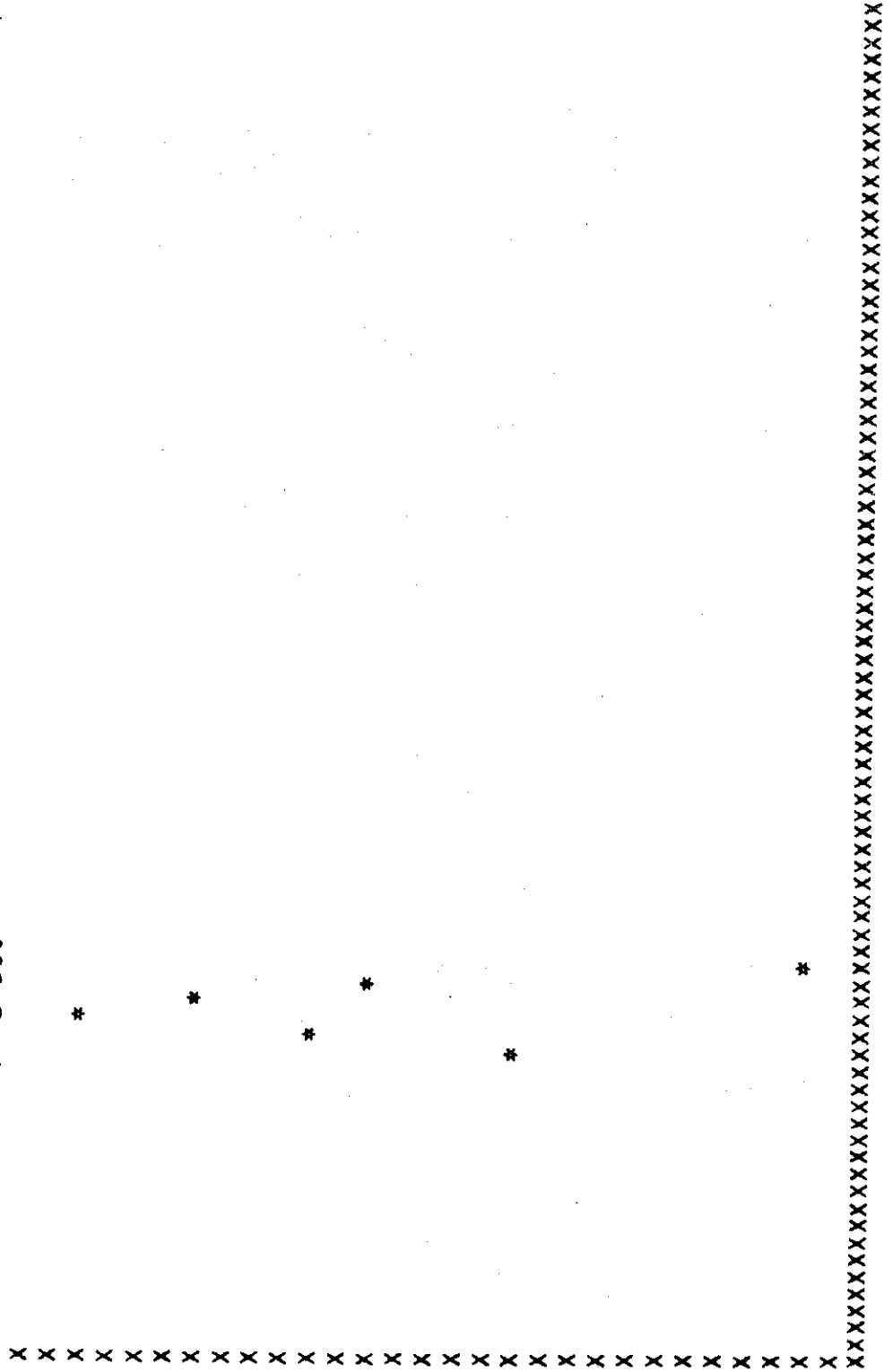





THIS IS A GRAPH OF THE SENSITIVITY OF  
ALTERNATIVE 6. THE ABSCISSA REPRESENTS  
UTILITY RANGING FROM 0 TO 1 AND THE ORDINATE  
REPRESENTS FREQUENCY OF OCCURANCE RANGING  
FROM 0 TO 30.

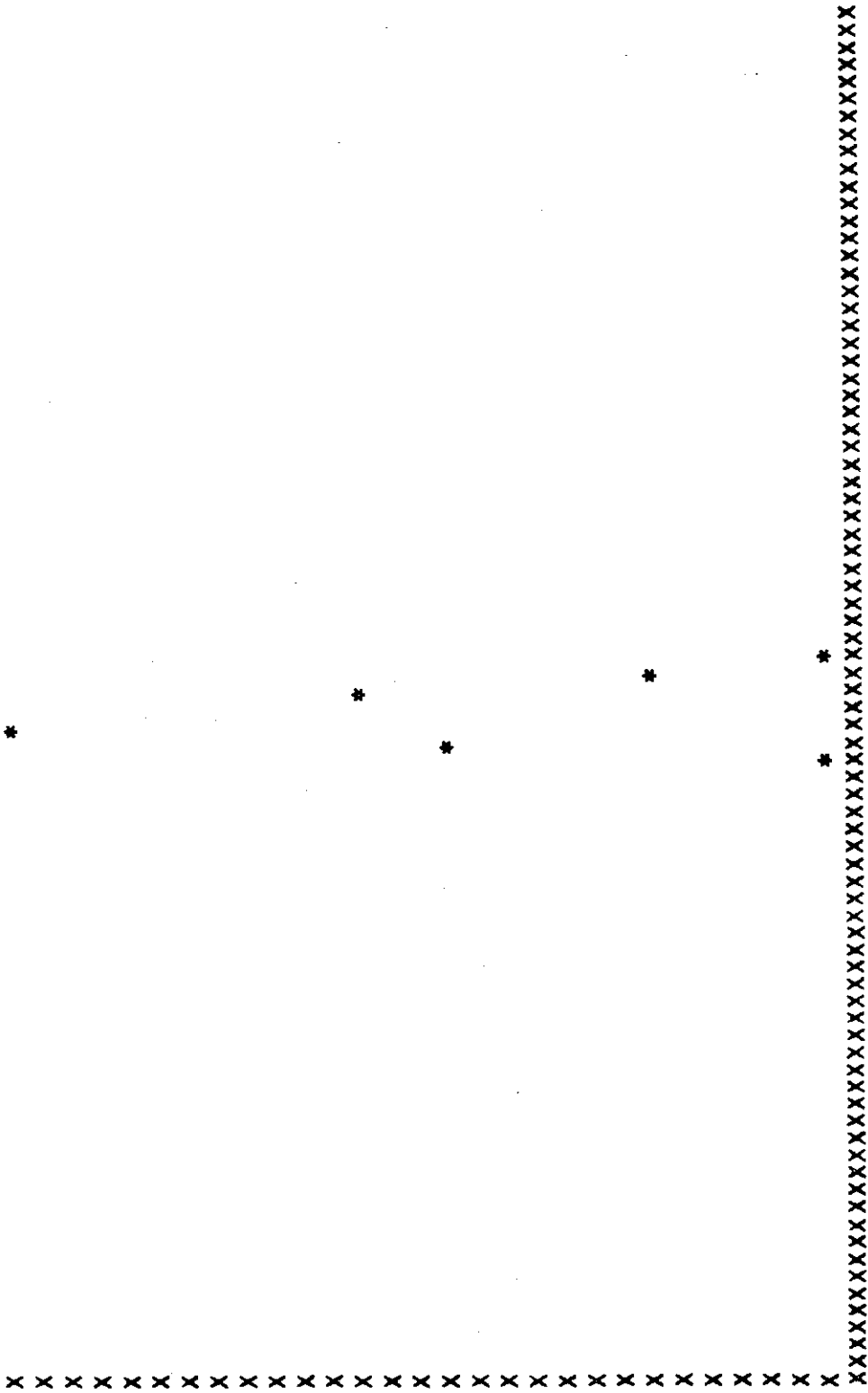



THIS IS A GRAPH OF THE SENSITIVITY OF  
ALTERNATIVE 8. THE ABSCISSA REPRESENTS  
UTILITY RANGING FROM 0 TO 1 AND THE ORDINATE  
REPRESENTS FREQUENCY OF OCCURANCE RANGING  
FROM 0 TO 30.

