

Applying Wireless Classroom to Build a Highly Interactive Learning Environment

Qiang Yang

School of Computer Science, Yangtze University, Jingzhou, China
Email: yangqiang@yangtzeu.edu.cn

Received May 23rd, 2012; revised June 24th, 2012; accepted July 8th, 2012

Wireless networks now support Web browsing, email, real-time chat, and access to remote computing resources. With the increasing use of small portable computers, this emerging communications infrastructure will enable many new Internet applications. The innovative project at the Yangtze University is currently exploring how educators can use portable handheld computers with wireless Internet access to improve teaching and learning in both local and wide area network environments.

Keywords: Cognitive Radio Networks; Artificial Mapping; Heterogeneous Network Convergence; Fuzzy Logic Inferences

Introduction

Mobile Education—or M-Education—is a new way of using wireless and mobile technologies for education by extending access to a desktop-based online virtual environment called MOOsYangtze to handheld devices used as part of a mobile collaborative community. Networked computers and corresponding applications facilitate distributed education with the mediation of learning activities by a constellation of various tools (such as shared spaces, whiteboards, etc.) having appropriate pedagogical approaches to collaboration and social interactions. One such example is MOOsYangtze: a community-oriented collaborative environment (Leidner, 1997; Hiltz, 1997). It provides an interactive map to navigate the virtual community, and a range of collaborative tools that provide access to shared content such as chat, message boards, and so on. Three versions of MOOsYangtze have been developed to date: a classic text-based MOO, a MOO extended to drive a Web browser, and a Java-based system. The current research considers how an application such as MOOsYangtze, which provides a collaborative learning environment, can be used to support educational activities in an active, mobile learning community (Jaffe, 2003; Gay, 2001; Shotsberger, 2001).

M-Education is designed to support a wireless online virtual community that is linked to the existing MOOsYangtze community. This will enable users who are interacting from either handheld devices or desktop computers to merge their learning experiences in a shared collaborative environment, both synchronously and asynchronously, with reference to the same underlying data (Goldman, 2001; Park, 1998; Good, 1994). The communication between a handheld and desktop is similar to that between two desktops. MOOsYangtze is an integral part of the Learning in Networked Communities (LiNC) project that has developed and evaluated software tools and applications for collaborative learning activities. Research has compellingly established the importance of learning communities. At the same time, mobility, flexibility and instant access of handheld devices add considerable freedom for people to collaborate anywhere, anytime (Aiken, 1992; Jones, 2001).

However, not enough research has been done in integrating the two concepts, for example trying to coordinate the use of desktop computers and handheld devices. We are beginning a research effort to do this; in this paper we use scenarios to explore an innovative use of wireless and mobile technologies in education.

Related Work

Numerous efforts are being made in the direction of using handheld devices for educational purposes. In cases where efforts consider possible coordination between handheld and desktop environments, none have proposed the rich interactions we envision in Meducation (Cotton, 1991). By examining a few related applications and concepts, we shall see how M-Education takes learning using wireless and mobile technologies one step further (Hewett, 1996). It focuses on how its users, in the context of their local environment, use handheld devices to access web-based medical knowledge and information. Although this project facilitates distributed and context-specific access to information, it makes no effort to coordinate such activities with other educational activities or peers (Walther, 1992; Gunter, 1995).

Wireless Internet Learning Devices (WILD) offers another vision for how one might use handheld devices in classrooms for computer-supported cooperative learning (CSCL). It is offered as a substitution for replacing CSCL applications that use desktop/laptop computers, a sort of paradigm shift (Huang, 2001; Liang, 2001). In contrast to our vision, the use of WILD in CSCL replaces—rather than integrates with—the use of desktop computers for distributed learning.

Perhaps the closest effort to the M-Education concept emphasized in this paper is, which uses handhelds to support collaborative learning (Fjuk, 2001). The authors merely suggest that handhelds may be used with desktops when the disadvantages of the former such as limited screen space become a considerable issue (Soloway, 2001). M-Education takes the counter approach, emphasizing that when desktops are not available, collaboration is still possible using handheld devices providing

the same enriched interactions as available on a desktop computer (Lundby, 2002; Roschelle, 2002). Our vision is not simply to supplement desktop user interfaces, but rather to explore the new and varied educational activities that become available in a mobile computing setting.

One of the target applications for MOOsYangtze is an ongoing community project called Save Our Streams. Save Our Streams is a national watershed education and outreach program that uses hands-on activities, such as cleaning up stream corridors and monitoring stream health, to help restore watersheds (Luchini, 2002). Through these activities, community members learn about the importance of protecting their local watershed and become more educated about the environmental, economic, recreational, and public health benefits of clean water.

The national Save Our Streams program consists of over 300 local chapters that coordinate activities for their local citizens. In Yangtze University, the Museum of Natural History at Jingzhou organizes field trips for grade school children and offers training sessions that teach others how to monitor and adopt a stream section. One of the major activities is an assessment of the stream's health through biological sampling, such as insect counts (Carroll, 2001). Participants on such trips learn about stream ecology and how to assess water quality. The data collected on these outings are often provided to the local and state government to augment their knowledge of the stream's condition.

Currently, the local Save Our Streams project conducts biological sampling at seven distinct locations. We have modeled each of these locations in MOOsYangtze, such that all of the data related to a particular site is available online (Rosson, 2002). Through the use of synchronous and asynchronous chat tools, Save Our Stream leaders as well as other community members, can discuss interesting findings such as the overall condition of the local stream.

Teaching and Learning in the Wireless Classroom

Local Area Wireless Access

The objective of Project Numina, a cooperative effort among faculty at UNCW, Pearson Education (Prentice-Hall), and Hypercube, is to use one seamless format to facilitate learning of abstract scientific and mathematical concepts by integrating media, interactive exercises, and hypertext materials into the classroom. Using handheld PCs (H/PCs) equipped with the appropriate software and connected by a wireless network to the Internet exposes students to a rich variety of Web resources that can help them learn abstract chemistry, mathematics, and computer science concepts (Farooq, 2003). This approach also enhances the learning experience by increasing student-instructor and student-student interactions.

Student Response Pads

One of the project's many educational applications is a Web-based interactive student response pad developed for use in large classroom settings. Numina's classroom environment consists of four Cisco Aironet wireless access points and 100 Hewlett-Packard Jornada H/PCs. Students use the H/PCs to respond to the instructor's questions, and the system stores their responses in a remote database and displays the collective re-

sponses graphically at the front of the classroom. SWATT. The Student Web Answer Technology Template, a server-side Web application implemented as a Java servlet, drives the system. SWATT is completely Web-based and does not require any special software on the client side other than a Web browser.

The instructor poses a question in a multiple-choice, true-false, or yes-no format and directs students to a Web site that generates a Web form on their computer screens through which they submit their responses. Multiple question-and answer scenarios are possible. A back backend database stores only responses to questions, not information about the student, so responses are anonymous. Real-time learning. The instructor controls the question number and whether to display the results—which appear as a dynamically updated bar chart generated from student responses as they are submitted to the database—on an overhead projector that all the students can view. Another interface provides a quiz-like format for questions and tracks responses by student identification number.

In contrast to the typical 2 to 3 percent response rate in a more traditional classroom setting, all of the students participating in our project respond to the instructor's questions. This suggests that students are more comfortable responding to a question when they see others doing the same. Another advantage of SWATT is that instructors can see immediately how well students comprehend a specific topic they have presented.

Other Applications

Project Numina is testing several other applications of Internet technology in the classroom. For example, we are studying how instructors and students use an electronic version of a widely adopted chemistry textbook that is on the Web—complete with graphics, equations, and illustrations—along with online references and other utilities that take advantage of the HTML format. We are also evaluating a pocket PC version of HyperChem, a software application from Hypercube that provides all the standard functions a student needs for general and organic chemistry on an H/PC. Finally, we are testing legacy DOS applications in the classroom using the Jornada H/PC, which supports MS-DOS emulation.

Types of Interaction in the Instruction and Learning Process

Computer-Mediated Interaction

With the addition of computer technology and Internet networking, the teaching and learning process is relocated from the physical to the virtual classroom. Virtual learning is a common term used to describe these changes. For instance, classrooms are no longer the only place to learn. Students in the classroom may use computer networks to communicate with each other rather than talk face to face. In the virtual classroom, there is not exact necessity for instructors to deliver lectures—they may lead a group discussion on the bulletin board systems (BBS) rather than give an in-class lecture. Instructors commonly regarded students entering a virtual classroom should do something more than find and read texts but involve the students in some activities, such as an assignment, an exercise, a debate, or problem-solving. This kind of interaction, the interaction via certain computer media and Internet connection like electronic mail (e-mail), BBS, or electronic meeting, has been called computer-mediated interaction /communication (CMC).

Computer-supported collaborative learning (CSCL) is one type of CMC application in education to enhance students' collaboration and interaction. CSCL is a computer-based network system that provides a shared interface for both individuals and groups to work on group work. In this design, students need to access to a specific bulletin board to fulfill assigned homework, such as peer review or group discussion. One of its major characteristics is its capability to allow students to engage in learning-related activities in diverse physical locations at any time. Teachers' major job in the CSCL learning environment is not to give lecture but to coordinate group work. Compared with face-to-face interaction in the traditional classroom, the (CMC) among students is more likely to encourage students' participations. Students' role thus becomes active learners rather than traditional passive learners.

The CSCL design enables three types of interaction between members in the classroom, including: 1) one-to-one interaction between a student and another student either in the same group or in different groups; and between a student and the teacher 2) one-to-many communication between the instructor and students; and 3) many-to-many communication between students. Nevertheless, the CSCL design cannot effectively improve students' learning without the support of appropriate pedagogical practice. For one reason, not every teaching and learning activity can effectively integrate new computer technologies. For another, there are many other external factors, such as classroom structure and the composition of student members that may affect the outcome of students' learning.

Human-Computer Interaction

Since the 80s, the emergence and application of "Computer-Assisted Instruction" (CAI) has led to an educational revolution, which significantly changes how people learn. Generally speaking, CAI are pre-designed computer software or web-based programmer designed to tutor students or users. When using CAI, learners follow the guidance on the screen to process the instruction. CAI design allows a learner to interact with a computer in a way that the CAI programmer responds to the learner's choosing of certain instruction materials. In other word, this type of instruction is a one-on-one instruction, or individualized instruction, because each student is automatically assigned with a computer who has been a virtual instructor or training assistant. Intelligent Tutoring Systems (ITS) is one type of CAI design aimed at providing the benefits of one-on-one instruction automatically and cost effectively. It goes beyond training simulations by answering users questions and providing individualized guidance. Moreover, it can assess each learner's actions within these interactive environments and develop a model of their knowledge, skills, and expertise. To some extent, ITS is acting as not only a problem-solving monitor but also a coach or consultant.

One of the major features of CAI is its design of human-computer interaction (HCI), concerned with "the structure of communication between human and machine, joint performance of tasks by humans and machines, and human capabilities to us machines." Simply speaking, when a student is using a computer in doing something, he/she is interacting with the computer. By simulation, computers can act like human beings, such as providing suggestions or ideas and giving evaluations. Nevertheless, unlike human beings, computers are unable to generate or express true and sophisticated emotions like anger

or frustration. Despite that CAI permits two-way communication between learners and the virtual tutor, such communication is lack of emotional tone and direct nonverbal cues because pre-designed CAI systems only can respond to learners in certain ways. Specifically, CAI is unable to provide more flexible choices of responses for learners. In spite of this limitation, CAI can benefit learners by always giving them immediate responses and allowing them to take far longer to learn missing knowledge and skills without coaching from a human instructor or an automated tutor. Moreover, learners' portfolio in the whole learning process could be recorded for further reviews.

Personal Device Supported Simultaneous Group Interaction

Owing to an increasing concern on how student-teacher and peer interaction can facilitate learning, some researchers attempt to create new type of computer technology to enhance student-teacher and peer interactions. EduClick, for instance, is our earlier effort aimed at designing a technology-enabled learning environment to enhance interactivity in the ordinary classroom. EduClick enables each student to use a remote controller to choose an answer in responding to the instructor's question. Following that, the instructor can use his/her remote controller to give evaluations to each student respectively. Having similar functions like EduClick, Group Decision/Process Support Systems (GPSS), which is often used in electronic meetings and business settings, can be also used as an educational technology-supported tool to improve the learning experience of each student in the group decision-making process. The GPSS functions in a way that students use the handheld devices, such as a learning pad, to respond to the instructors' questions in either multi-choice or yes-no and true-false format, and then the system stores their responses in a remote database and displays the collective responses on the screen in the front of the classroom. Meanwhile, all responses can be saved in a session file, allowing students and instructors to analyze the results of the questions and answers in follow-up work.

GPSS enables a spontaneous two-way communication between students and the instructor, specifically allowing one-to-many and many-to-many communication. Such interaction is called as "personal device supported simultaneously group interaction." When the instructor poses a question, each student can respond to this question spontaneously. As such, the instructor can gather and perceive all different opinions in a short time and then give respective feedbacks. Under this circumstance, the role of the instructor has transformed from traditional "sage on the stage" to a classroom coordinator who coordinates the classroom ongoing discussion and interaction. Students' role as passive learner is also shifted to autonomous or active learner. GPSS was reported to offer an easy means to gather attention, to promote students' participations, and to generate a lot of rapid feedback from both students and the instructor. In using a GPSS, students will no longer have to raise their hands to speak, interrupt each other in order to talk, or forgo making a comment because someone else is talking. Since the instructor can see immediately how well students comprehend a specific topic or issue he/she has presented and in turn provide immediate feedback, the communication between the instructor and students becomes more effective. In addition, students may not have to take notes when a GPSS is presented because all comments were recorded by the system.

Despite of these advantages, several limitations of the GPSS application have been noted. The changing conditions within each class (i.e. the composition of class members and the characteristic of the instructor and students) may have migrated effects of using a GPSS. Moreover, it is difficult to determine if in fact all students were participating during the electronic discussion. While the instructor was observing the students during their electronic discussion and participation appeared to be high among all students, it is possible that a few students may not have engaged in the discussion, but merely observed others or did something else.

Learning Environment Design with Wireless Digital Learning Assistant

Since the educational reform was demonstrated and undergone in 1998, the Ministry of Education in Taiwan has drawn up and implemented several educational technology-related projects in order to promote student-teacher and peer interaction in the classroom. The highly interactive classroom (HIC), a learning environment system designed and developed by Learning Technology Lab of National Central University in Taiwan, is one of these ongoing projects.

The original version of highly interactive classroom (HIC) is a 3-layered structure for one computer allocated classroom within EduClick. Each student in the HIC has an infrared remote controller to participate learning activities, such as formative evaluation and prompt Q & A. The infrared remote controller lets student interacting with teacher and other students through the classroom computer coordination. In essence, HIC is a wireless communication environment with handheld devices. With the device, the instructor can present instruction materials, conduct evaluations, and control activities pace in the classroom. However, the limited function of infrared remote controller restrains activity types the instructor could apply.

In this study, a more flexible and powerful HIC environment design would be proposed, shown in **Figure 1**. The HIC with wireless digital learning assistant (WDLA) retains wireless communication by replacing infrared with 802.11b through wireless access points, and replacing remote controller with WDLA as handheld device. Basically, the WDLA is a helpful device that can support all types of the interaction we have mentioned. Teachers perform instruction activities by operating the master computer allocated in the classroom, and each student uses a handheld WDLA to interact with others, respectively. An electronic whiteboard is connected to the master computer so that teacher may perform his/her instruction as

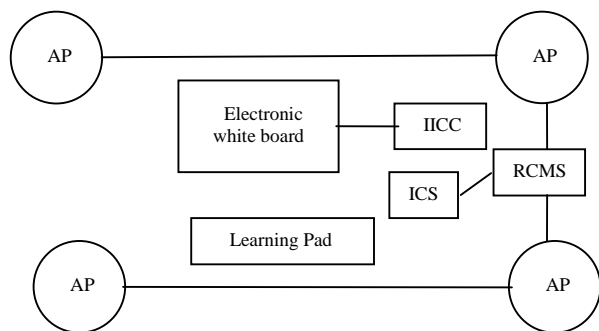

Figure 1. Learning environment design with wireless digital learning assistant.

usual. Students read digitized textbook, practice assigned exercises, and participate in instruction activities on WDLA. For assisting instruction and learning activities, there are two servers in the HIC, including interactive classroom server (ICS) and resource and class management server (RCMS). The ICS is a coordinator, which coordinates instruction and learning activities. The RCMS is a resource center, which manages instruction resources and keeps track of individual student's learning portfolios.

Highly Interactive Classroom Servers

The server side, including RCMS and ICS, of the HIC with WDLA handles resources and interactivities. RCMS stores instruction and learning resources as well as activities content. Furthermore, students' learning portfolios and teacher's instruction records are also stored on it. ICS keeps track of individual operations as well as coordinates the student-teacher and peer interaction. The separation of content and interaction services functions for load sharing and system extension consideration. More than one classroom could share the same RCMS. However, the more students participate in classroom activities, the more interactions would be generated. Hence, each single classroom should equip an ICS in order to guarantee real time interaction.

Resource and Class Management Server

RCMS is the content and activity center in the classroom. All of the instruction materials should be arranged on it before class and could be used in class. After class, students could review in-class records the instructor made on the electronic whiteboard or do the exercises assigned by the instructor. The server provides essential tools, such as quiz authoring and instruction materials sequencing, for teacher to prepare course content. The well arranged instruction materials, including pictures, videos, audios, homepages, and presentation files, would be accessed by IICC. Furthermore, quiz would be consumed in or after class via ILC. Besides content and activities management, RCMS is the class member manager as well. The instructor sets up students' profiles, including names, class IDs, E-mail addresses, etc., in the RCMS. Students' records generated in classroom activities are stored on it. Each student could login to the server and review what he/she had done in class.

Interactive Classroom Server

ICS coordinates activities and contents during instruction no matter instructor's lecturing or individual student's practicing. ILC will automatically log in the ICS once WDLA boots up or carries into the classroom by a student. Successive operations of ILC will be under ICS monitoring. All the operations, such as drawing and clicking on WDLA, would be transformed to messages and commands. ICS parses messages and commands to perform corresponding functions. For instance, a student requests for a specific quiz on ILC, the requesting command will be sent to ICS. As ICS receiving the command, it tells RCMS the ILC ID and quiz name. The requested quiz would be transmitted to the ILC. After finishing the quiz, responses for each item would be automatically recorded on the student's portfolio. **Figure 2** shows the role of ICS in the HIC. Operations on the IICC are also under ICS governing. IICC requests

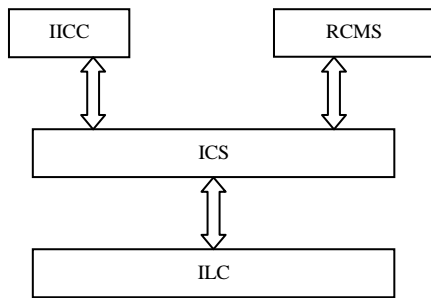

Figure 2.
ICS is the coordinator of activities and content.

instruction content to ICS and the requesting command will be sent to RCMS. After receiving the command, RCMS transmits the requested content to IICC directly.

On the other hand, once the instructor activates the broadcast function, ICS negotiates with IIC communication control design of all ILC in the classroom and has them display the IICC instruction frame or record instruction operations on the RCMS.

The needed content of instruction and learning could be transmitted to IICC and ILCs directly or indirectly through ICS depends on the types of activities. Most broadcasting and unicast operations are centrally controlled by ICS. Therefore, content transmission should be through the medium of ICS indirectly. Otherwise, ICS processes commands, messages, and records only. Content should be directly transmitted from RCMS to IICC and ILCs. Overall, the present IIC design is a new attempt to integrate the four types of classroom interactivity described earlier, benefiting students from providing a number of instructional tools to enhance student-teacher and peer interaction and thus to effect students' learning.

Expanding Options

Wireless devices enhance Web-based professional development by giving teachers immediate access to other colleagues. For example, at small, rural schools, only one or two teachers from the same discipline may be available for collaboration at any given time. Participants from different schools could use wireless devices to notify colleagues of their availability to chat synchronously online; if the chat is text-based, the transcript could become part of an archive asynchronously accessible by all participants.

Surfing the Web while they conduct a chat would help teachers jointly plan lessons that incorporate Web resources while they also benefit from having access to the experiences and insights of a large pool of practicing teachers. This would be especially useful to teachers in training, who often only have the opportunity to collaborate with their mentors. The education community has long lamented that teachers generally do not produce written or even oral records of their classroom strategies. Handheld wireless devices could give teachers a highly portable way of documenting implementation results, which they could then share with colleagues face to face, in a chat room, on a discussion board, or as a Web page. H/PC features such as handwriting-recognition software and the ability to record short voice messages will expand a teacher's options for record keeping both in and out of the classroom. As yet, little is known about the potential impact of wireless technology on

teaching and learning.

Anecdotal evidence suggests that students enjoy the technology and become more active in their learning when H/PCs are used in the classroom. There is every indication that in the near future wireless data devices will be as widespread as wireless voice devices are now. Rather than just migrating a few PC functions to a mobile platform, we envision these devices as actually replacing the desktop PC's full functionality. Popular technologies such as palmtops and Internet-ready cell phones lack a fullscale browser that can handle a wide variety of Web content. In contrast, in addition to playing audio and video files, H/PCs already have browsers that support HTML, Java, and JavaScript. Given the increasing importance of the Web to both educators and developers of educational materials, this difference has profound implications for teaching and learning.

Conclusion

We have presented a summary of design work in progress, describing our vision of M-Education, an architecture for integrating the use of wireless technologies into an existing collaborative environment. The consequence is that teachers, students, and peers in a distributed field environment can interact seamlessly with their counterparts in a desktop environment. They are also able to examine and modify shared data maintained in the online community. The basic architecture is in place and we are beginning to develop and evaluate scenarios of the sort described here.

REFERENCES

- Aiken, M. W. (1992). Using a group decision support system as a teaching tool. *Journal of Computer-Based Instruction*, 19, 82-85.
- Carroll, J. M., Rosson, M. B., Isenhour, P., Ganoe, C. H., Dunlap, D., Fogarty, J., Schafer, W., & Van Metre, C. (2001). Designing our town: Moosburg. *International Journal of Human-Computer Studies*, 54, 725-751. doi:10.1006/ijhc.2000.0438
- Cotton, K. (1991). Computer-assisted instruction. *School Improvement Research Series*. URL: <http://www.nwrel.org/scpd/sirs/5/cu10.html>
- Farooq, U., Isenhour, P. L., Carroll, J. M., & Rosson, M. B. (2003). MOOsYangtze++: Moving towards a wireless virtual community. *Proceedings of the International Conference on Wireless Networks*, Las Vegas, 10 June 2002.
- Fjuk, A., & Smørðal, O. (2001). Networked computers' incorporated role in collaborative learning. *European Perspectives on Computer-Supported Collaborative Learning*, Maastricht, 22-24 March 2001.
- Gay, G., Stefanone, M., Grace-Martin, M., & Hembrooke, H. (2001). The effects of wireless computing in collaborative learning environments. *International Journal of Human-Computer Interaction*, 13, 257-276. doi:10.1207/S15327590IJHC1302_10
- Goldman, P., & Kaufman, B. J. (2001). How to push an elephant through a straw: Using wireless technology in a web-enhanced skills program. *International Review of Law Computers & Technology*, 15, 281-299. doi:10.1080/13600860220108094
- Good, T. L., & Brophy, J. (1994). *Contemporary educational psychology* (5th ed.). Boston, MA: Allyn & Bacon.
- Gunter, M. A. et al. (1995). Cooperative learning models—Improving student achievement using small groups. In M. A. Gunter, T. H. Estes, & J. H. Schwab (Eds.), *Instruction: A models approach* (pp. 222-230). Boston, MA: Allyn & Bacon.
- Hewett (1996). Chapter 2: Human-computer interaction. In *ACM SIGCHI curricula for human-computer interaction* (pp. 5-27). New York, NY: ACM SIGCHI. URL: <http://www.acm.org/sigchi/cdg/cdg2.html>
- Hiltz, S. R., & Wellman, B. (1997). Asynchronous learning networks as a virtual classroom. *Communications of the ACM*, 40, 44-49. doi:10.1145/260750.260764

- Huang, C. W., Liang, J. K., & Wang, H. Y. (2001). EduClick: A computer-supported formative evaluation system with wireless devices in ordinary classroom. *Proceedings of the International Conference on Coastal Engineering*, Sydney, 16-21 July 2000, 1462-1469.
- Jaffe, D. (2003). Virtual transformation: Web-based technology and pedagogical change. URL. <http://it.coe.uga.edu/ITForum/paper58/paper58.htm>
- Jones, C., Connolly, M., Gear, A., & Read, M. (2001). Group interactive learning with group process support technology. *British Journal of Educational Technology*, 32, 571-586. [doi:10.1111/1467-8535.00226](https://doi.org/10.1111/1467-8535.00226)
- Leidner, D. E., & Fuller, M. (1997). Improving student learning of conceptual information: GSS supported collaborative learning vs. individual constructive learning. *Decision Support Systems*, 20, 149-163. [doi:10.1016/S0167-9236\(97\)00004-3](https://doi.org/10.1016/S0167-9236(97)00004-3)
- Liang, J. K., Wang, H. Y., Huang, C. W., Chang, S. B., & Chan, T. W. (2001). Highly interactive instruction environment for classroom-integration of wireless testing system and learning information management system. *Learning across the Ages—Looking Back and Looking Forwards*, 311.
- Luchini, K., Quintana, C., Curtis, M., Murphy, R., Krajcik, J., Soloway, E., & Suthers, D. (2002). Using handhelds to support collaborative learning. *Proceedings of the Conference on Computer Support for Collaborative Learning: Foundations for a CSCL Community*, Boulder, 2002, 704-705.
- Lundby, K., Smørdal, O., Larsen, A., & Fjuk, A. (2002). Networked PDAs in a community of learners. *Proceedings of the Conference on Computer Support for Collaborative Learning: Foundations for a CSCL Community*, Boulder, 2002, 548-549.
- Park, R., & Burris, R. (1978). Computer-aided instruction in law: Theories, techniques, and trepidations. *Journal of the American Bar Foundation*, 3, 1-50.
- Roschelle, J., & Pea, R. (2002). A walk on the WILD Side: How wireless handhelds may change CSCL. *Proceedings of the Conference on Computer Support for Collaborative Learning: Foundations for a CSCL Community*, Boulder, 2002, 51-60.
- Rosson, M. B., & Carroll, J. M. (2002). *Usability engineering: Scenario-based development of human-computer interaction*. San Francisco, CA: Morgan Kaufmann.
- Shotsberger, P. G., & Vetter, R. (2001). Teaching and learning in the wireless classroom. *Computer*, 34, 110-111. [doi:10.1109/2.910902](https://doi.org/10.1109/2.910902)
- Soloway, E., Norris, C., Blumenfeld, P., Fisherman, B., Krajcik, J., & Marx, R. (2001). Handheld devices are ready-at-hand. *Communications of the ACM*, 44, 15-20.
- Walther, J. B. (1992). Interpersonal effects in computer-mediated interaction. *Communication Research*, 19, 39. [doi:10.1177/009365092019001003](https://doi.org/10.1177/009365092019001003)