

HEISENBERG CATEGORIFICATION AND HILBERT SCHEMES

SABIN CAUTIS AND ANTHONY LICATA

ABSTRACT. Given a finite subgroup $\Gamma \subset SL_2(\mathbb{C})$ we define an additive 2-category \mathcal{H}_Γ whose Grothendieck group is isomorphic to an integral form \mathfrak{h}_Γ of the Heisenberg algebra. We construct an action of \mathcal{H}_Γ on derived categories of coherent sheaves on Hilbert schemes of points on the minimal resolutions $\widehat{\mathbb{C}^2/\Gamma}$.

CONTENTS

1. Introduction	2
1.1. Analogy with Kac-Moody Lie algebra actions	2
1.2. The 2-category \mathcal{H}_Γ	3
1.3. Actions of \mathcal{H}_Γ	3
1.4. Khovanov's Heisenberg categorification	3
1.5. Organization	4
1.6. Acknowledgements	4
2. Quantum Heisenberg algebras	4
2.1. The McKay correspondence	4
2.2. The quantum Heisenberg algebra associated to Γ	5
2.3. The Fock space	6
3. The category \mathcal{H}_Γ	6
3.1. The algebra B^Γ	6
3.2. The category \mathcal{H}'_Γ	7
3.3. The category \mathcal{H}_Γ	10
3.4. Main Theorem #1	10
3.5. Remarks on relations in \mathcal{H}'_Γ	11
4. Action of \mathcal{H}_Γ	13
4.1. Categories	13
4.2. Functors \mathbb{P} and \mathbb{Q}	13
4.3. Natural transformations	14
4.4. Main Theorem #2	19
5. Proof of Theorem 2	20
5.1. Composition of X 's	20
5.2. Adjoint relations	21
5.3. Dots and adjunctions	22
5.4. Pitchfork relations	25
5.5. Dots and crossings	27
5.6. Composition of crossings relations	28
5.7. Counter-clockwise circles and curls	29
6. Graphical calculus and \mathcal{H}^Γ	30
6.1. The 2-category \mathcal{H}^Γ	30
6.2. The functor $\eta : \mathcal{H}^\Gamma \rightarrow \mathcal{H}_\Gamma$	32

6.3. Proposition 2 for \mathcal{H}^Γ	33
6.4. Relation to Hilbert schemes	37
7. Proof of Main Theorem 1	39
8. An abelian 2-representation of \mathcal{H}_Γ	40
8.1. Superalgebras and supermodules	41
8.2. The algebras B_n^Γ	41
8.3. Functors \mathbf{P} and \mathbf{Q}	42
8.4. Natural Transformations	42
8.5. The main Theorem	43
8.6. Relation to wreath products $\mathbb{k}[\Gamma^n \times S_n]$	43
9. Open Problems	44
9.1. Relation to Kac-Moody 2-categories $\mathcal{U}(\mathfrak{g})$	44
9.2. Degenerate affine Hecke algebras	44
9.3. The structure of $\text{End}_{\mathcal{H}_\Gamma}(\text{id})$	46
9.4. Hochschild cohomology of Hilbert schemes	46
Appendix A. The case $\Gamma = \mathbb{Z}_2$	46
References	48

1. INTRODUCTION

The well-documented relationship between the Heisenberg algebra and Hilbert schemes of points on a surface S involves an action of the Heisenberg algebra on the cohomology $\oplus_n H^*(\text{Hilb}^n(S))$, [N1, G]. Inspired by other constructions from geometric representation theory, one expects this Heisenberg action on cohomology to lift to algebraic K_0 -theory, though in general lifting this action is not straightforward. In the special case when $S = \mathbb{C}^2$ one can use the natural \mathbb{C}^\times action together with localization techniques to define Heisenberg algebra actions on localized equivariant K-theory (see [FT, SV]).

After K-theory there is yet another level where one considers the derived categories of coherent sheaves $\oplus_n DCoh(\text{Hilb}^n(S))$. Then one should define a categorical object related to the Heisenberg algebra which acts on these triangulated categories.

More precisely, the Hilbert schemes $\{\text{Hilb}^n(S)\}_{n \in \mathbb{N}}$ naturally form a 2-category $\text{Hilb}(S)$:

- (1) The objects of $\text{Hilb}(S)$ are the natural numbers \mathbb{N} ;
- (2) The 1-morphisms from m to n are compactly supported objects in $DCoh(\text{Hilb}^m(S) \times \text{Hilb}^n(S))$. Composition of 1-morphisms is given by convolution.
- (3) For $\mathcal{P}_1, \mathcal{P}_2 \in DCoh(\text{Hilb}^m(S) \times \text{Hilb}^n(S))$, the space of 2-morphisms from \mathcal{P}_1 to \mathcal{P}_2 is the space $\text{Ext}^*(\mathcal{P}_1, \mathcal{P}_2)$. The composition of 2-morphisms is the natural composition of Exts.

So to give a categorical Heisenberg action one should define a 2-category \mathcal{H}_S and a 2-functor $\mathcal{H}_S \rightarrow \text{Hilb}(S)$. The Grothendieck group of \mathcal{H}_S should be isomorphic to the Heisenberg algebra so that passing to K-theory one gets a Heisenberg action on $\oplus_n K_0(\text{Hilb}^n(S))$. In this paper we construct such a 2-category $\mathcal{H}_S = \mathcal{H}_\Gamma$ and a 2-functor $\mathcal{H}_\Gamma \rightarrow \text{Hilb}(S)$ when $S = \widehat{\mathbb{C}^2/\Gamma}$ is the minimal resolution of the quotient of \mathbb{C}^2 by a non-trivial finite subgroup $\Gamma \subset SL_2(\mathbb{C})$ (Theorems 1 and 2). In particular, we obtain a (quantum) Heisenberg algebra action on $\oplus_n K_0(\text{Hilb}^n(S))$.

1.1. Analogy with Kac-Moody Lie algebra actions. There are parallel stories for Heisenberg algebras \mathfrak{h}_Γ and for Kac-Moody Lie algebras $U(\mathfrak{g})$. In [N2] and [N3] Nakajima constructs actions of the enveloping algebra $U(\mathfrak{g})$ on the cohomology and K-theory of quiver varieties, generalizing earlier work of Ginzburg for $U(\mathfrak{sl}_n)$ [CG]. On the other hand, Khovanov-Lauda [KL] define a 2-category $\mathcal{U}(\mathfrak{g})$

whose Grothendieck group is isomorphic to (an integral version of) the quantized enveloping algebra. There is also independent and very similar work of Rouquier [R] in the same direction.

In [CKL] the authors, together with Joel Kamnitzer, construct a “geometric categorical \mathfrak{g} action” on the derived category of coherent sheaves on quiver varieties. This action (at least conjecturally) induces an action of the 2-categories $\mathcal{U}(\mathfrak{g})$ on the derived categories of quiver varieties. The 2-categories $\mathcal{U}(\mathfrak{g})$ and these actions on the derived categories of quiver varieties are analogous to our Heisenberg 2-categories \mathcal{H}_Γ and their action on the derived categories of Hilbert schemes.

1.2. The 2-category \mathcal{H}_Γ . By the McKay correspondence, isomorphism classes of finite subgroups $\Gamma \subset SL_2(\mathbb{C})$ are parametrized by simply-laced affine Dynkin diagrams (i.e. diagrams of type \widehat{A}_n , \widehat{D}_n , \widehat{E}_6 , \widehat{E}_7 and \widehat{E}_8). These diagrams also parametrize simple simply-laced affine Lie algebras \mathfrak{g} , each of which has a distinguished “homogeneous” Heisenberg subalgebra $\mathfrak{h}_\Gamma \subset \mathfrak{g}$.

The isomorphism class of the Heisenberg algebra \mathfrak{h}_Γ does not depend on Γ . However, the choice of Γ determines a presentation of \mathfrak{h}_Γ which we describe in section 2.2, and a 2-category \mathcal{H}_Γ , which we define in section 3. The 2-morphisms in \mathcal{H}_Γ are defined using a planar graphical calculus reminiscent of the graphical calculus used by Khovanov-Lauda [KL] in their categorification of quantum groups. Our first theorem (1) says that the Grothendieck group $K_0(\mathcal{H}_\Gamma)$ is isomorphic to the Heisenberg algebra \mathfrak{h}_Γ in its Γ -presentation.

Note that the Heisenberg algebras \mathfrak{h}_Γ are isomorphic to each other as abstract algebras, but the 2-categories \mathcal{H}_Γ for different Γ are not equivalent to one another. In this sense, different actions of the Heisenberg algebra are often shadows of essentially different categorical actions. This is in contrast to the case of Kac-Moody Lie algebras, where the categorifications in [KL] and [R] seem to be more rigid.

1.3. Actions of \mathcal{H}_Γ . A direct relationship between the finite group $\Gamma \subset SL_2(\mathbb{C})$ and the Heisenberg algebra \mathfrak{h}_Γ can be formulated in two closely related ways (one algebraic and the other geometric). In the algebraic setting (following [FJW]) one considers the wreath products $\Gamma^n \rtimes S_n$ of Γ with the symmetric group S_n . Then one constructs the basic representation of \mathfrak{h}_Γ on the Grothendieck groups of the module categories $\mathbb{C}[\Gamma^n \rtimes S_n]\text{-mod}$. Geometrically one considers the Hilbert schemes $\widehat{\text{Hilb}}^n(\mathbb{C}^2/\Gamma)$ and constructs the basic representation of \mathfrak{h}_Γ on their cohomology.

We will work in a setting that shares features with both the algebraic and geometric constructions above by considering directly the bounded derived categories $D(A_n^\Gamma\text{-gmod})$ of finitely generated graded A_n^Γ modules. Here A_n^Γ is the algebra

$$A_n^\Gamma := [(\text{Sym}^*(V^\vee) \rtimes \Gamma) \otimes (\text{Sym}^*(V^\vee) \rtimes \Gamma) \otimes \cdots \otimes (\text{Sym}^*(V^\vee) \rtimes \Gamma)] \rtimes S_n$$

which inherits the natural grading from $\text{Sym}^*(V^\vee)$ (here $V = \mathbb{C}^2$).

We recall why $D(A_n^\Gamma\text{-gmod})$ is equivalent to derived categories of Hilbert schemes in section 6.4 and explain the relationship to $\mathbb{C}[\Gamma^n \rtimes S_n]\text{-mod}$ in section 8.6. Our second main theorem (Theorem 2) constructs a natural action of the Heisenberg category \mathcal{H}_Γ on $\bigoplus_n D(A_n^\Gamma\text{-gmod})$.

The Grothendieck group $K_0(A_n^\Gamma\text{-mod})$ is isomorphic to $K_0(\mathbb{C}[\Gamma]^n \rtimes S_n\text{-mod})$. On the other hand, $K_0(A_n^\Gamma\text{-mod}) \cong K_0(\widehat{\text{Hilb}}^n(\mathbb{C}^2/\Gamma))$ is isomorphic to the cohomology of $\widehat{\text{Hilb}}^n(\mathbb{C}^2/\Gamma)$. Thus the category $\bigoplus_n D(A_n^\Gamma\text{-mod})$ gives a common categorification of the spaces used by Nakajima, Grojnowski and Frenkel-Jing-Wang.

1.4. Khovanov’s Heisenberg categorification. Our 2-category \mathcal{H}_Γ takes as its input data the embedded finite subgroup $\Gamma \subset SL_2(\mathbb{C})$, and the definition of \mathcal{H}_Γ can be generalized to an arbitrary embedded finite group $\Gamma \subset SL_n(\mathbb{C})$. The associated Heisenberg 2-category will then act naturally on $\bigoplus_n D(A_n^\Gamma\text{-mod})$ where A_n^Γ is defined as above except that now V is the standard representation of $SL_n(\mathbb{C})$. In fact, such a construction already makes sense when Γ is trivial and $\dim(V) = 0$. In this case the definition of the associated Heisenberg category is due to Khovanov [K].

Unsurprisingly, some of our constructions share many features with (and take a good deal of inspiration from) his construction. In Khovanov’s construction, like ours, the 1-morphisms are generated by two elements P and Q which are biadjoint up to shift. The difference appears in the structure of 2-morphisms. Here the rôles of Γ and V become apparent. In particular, our categories inherit a non-trivial \mathbb{Z} grading from the natural grading on the exterior algebra $\Lambda^*(V)$. This grading makes the Grothendieck group of \mathcal{H}_Γ into a $\mathbb{Z}[t, t^{-1}]$ module which categorifies a quantum deformation of the Heisenberg algebra.

1.5. Organization.

- Section 2 defines the (quantum) Heisenberg algebra \mathfrak{h}_Γ . Our choice of generators for \mathfrak{h}_Γ differs somewhat from the choices made elsewhere in the literature.
- Section 3 defines the 2-category \mathcal{H}_Γ which categorifies \mathfrak{h}_Γ . We also define a map from \mathfrak{h}_Γ to the Grothendieck group of \mathcal{H}_Γ . This map is shown to be an isomorphism in section 7 (Theorem 1).
- Sections 4 and 5 are concerned with defining an action of \mathcal{H}_Γ on $\oplus_n D(A_n^\Gamma\text{-mod})$.
- In Section 6 we study a slightly different 2-category \mathcal{H}^Γ using an alternative simplified graphical calculus. \mathcal{H}^Γ is “Morita equivalent” to \mathcal{H}_Γ in the sense that the spaces of 2-morphisms in \mathcal{H}^Γ and \mathcal{H}_Γ are Morita equivalent (subsequently the 2-representation theories of \mathcal{H}^Γ and \mathcal{H}_Γ are equivalent). We construct a natural functor $\eta : \mathcal{H}^\Gamma \rightarrow \mathcal{H}_\Gamma$ which induces an isomorphism at the level of Grothendieck groups (so both \mathcal{H}^Γ and \mathcal{H}_Γ categorify \mathfrak{h}_Γ). The 2-category \mathcal{H}^Γ is of independent interest but another motivation for introducing it is to facilitate the graphical computations needed to prove Theorem 1.
- In section 8 we sketch a second, simpler (non-derived) action of \mathcal{H}_Γ , related to the action of section 4 by Koszul duality.
- Section 9 contains a discussion of currently unanswered questions and further directions.
- The appendix: most of the paper assumes the Dynkin diagram associated to $\Gamma \subset SL_2(\mathbb{C})$ is simply-laced, which simplifies notation but fails to cover the case $\Gamma = \mathbb{Z}_2$. In section A we collect the required definitions for $\Gamma = \mathbb{Z}_2$ (with these modifications the main theorems of the paper hold for any nontrivial Γ). The definition of the Heisenberg category for the trivial subgroup of $SL_2(\mathbb{C})$ is of interest in its own right, but is not discussed directly in this paper.

1.6. Acknowledgements. The authors would like to thank Mikhail Khovanov for several useful conversations and for giving us an early version of his paper [K]. We would also like to thank Igor Frenkel for sharing with us his unpublished notes with Khovanov and Malkin on categorification and vertex operator algebras [FKM]. This project began when both authors were at the program “Homology Theory of Knots and Links” at MSRI in 2010. We thank MSRI for its hospitality and great working environment. S.C. was supported by National Science Foundation Grant 0801939/0964439.

2. QUANTUM HEISENBERG ALGEBRAS

2.1. The McKay correspondence. Fix an algebraically closed field \mathbb{k} of characteristic zero. Let $\Gamma \subset SL_2(\mathbb{k})$ denote a finite subgroup (in our discussion this can include $\Gamma = \mathbb{k}^\times$ the Cartan subgroup of diagonal matrices). For notational convenience, the body of the paper assumes that $\Gamma \neq \mathbb{Z}_2$. We deal with this extra case in appendix A.

Denote by V the standard two dimensional representation of Γ . Under the McKay correspondence the finite subgroup Γ corresponds to an affine Dynkin diagram with vertex set I_Γ and edge set E_Γ . By definition each vertex $i \in I_\Gamma$ is indexed by an irreducible representation V_i of Γ and two vertices $i, j \in I_\Gamma$ are joined by k edges where k is the number of times V_j appears as a direct summand of $V_i \otimes V$. Notice that since V is self dual this relation is symmetric in i and j .

For instance, when $G = \mathbb{Z}/n\mathbb{Z}$ then we get the affine Dynkin diagram \tilde{A}_{n-1} , which is an n cycle. When $\Gamma = \mathbb{k}^\times$ the associated diagram is the Dynkin diagram \tilde{A}_∞ of the Lie algebra \mathfrak{sl}_∞ .

Define the *quantum Cartan matrix* C_Γ to be the matrix with entries $\langle i, j \rangle$ indexed by $i, j \in I_\Gamma$ given by

$$\langle i, j \rangle = \begin{cases} t + t^{-1} & \text{if } i = j \\ -1 & \text{if } i \neq j \text{ are connected by an edge} \\ 0 & \text{if } i \neq j \text{ are not connected by an edge} \end{cases}$$

Note that at $t = 1$ the matrix C_Γ becomes the extended Cartan matrix of type ADE (this is the McKay correspondence between nontrivial finite subgroups $\Gamma \subset SL_2(\mathbb{C})$ and simply-laced affine Dynkin diagrams).

2.2. The quantum Heisenberg algebra associated to Γ . Fix an algebraically closed field \mathbb{k} of characteristic zero. We define the Heisenberg algebra \mathfrak{h}_Γ associated to Γ to be the unital $\mathbb{k}[t, t^{-1}]$ algebra with generators $p_i^{(n)}, q_i^{(n)}$ for $i \in I_\Gamma$ and integers $n \geq 0$ and relations

$$(1) \quad p_i^{(n)} p_j^{(m)} = p_j^{(m)} p_i^{(n)} \text{ for all } i, j \in I_\Gamma,$$

$$(2) \quad q_i^{(n)} q_j^{(m)} = q_j^{(m)} q_i^{(n)} \text{ for all } i, j \in I_\Gamma,$$

$$(3) \quad q_i^{(n)} p_i^{(m)} = \sum_{k \geq 0} [k+1] p_i^{(m-k)} q_i^{(n-k)} \text{ for all } i \in I_\Gamma,$$

$$(4) \quad q_i^{(n)} p_j^{(m)} = \sum_{k \geq 0} p_j^{(m-k)} q_i^{(n-k)} \text{ for all } i \neq j \in I_\Gamma \text{ with } \langle i, j \rangle = -1$$

$$(5) \quad q_i^{(n)} p_j^{(m)} = p_j^{(m)} q_i^{(n)} \text{ for all } i \neq j \in I_\Gamma \text{ with } \langle i, j \rangle = 0.$$

Here $[k+1] = t^{-k} + t^{-k+2} + \dots + t^{k-2} + t^k$ denotes the quantum integer, and in the above relations we have set $p_i^{(0)} = q_j^{(0)} = 1$ and $p_i^{(k)} = q_i^{(k)} = 0$ when $k < 0$ (thus the summations in the above relations are all finite.)

Most mathematical literature about the Heisenberg algebra uses a slightly different presentation than the one above. Typically, the (undeformed) Heisenberg algebra associated to Γ is presented as \mathbb{k} algebra generated by elements $a_i(m)$, $m \in \mathbb{Z}$ and $i \in I_\Gamma$, together with and a central element c ; the defining relations are

$$[a_i(m), a_j(n)] = m \delta_{m, -n} \langle i, j \rangle c,$$

where $\langle i, j \rangle$ is the (i, j) entry of the Cartan matrix. A different set of generators of the Heisenberg algebra is then obtained as the homogeneous components in z of the ‘‘halves of vertex operators’’

$$\exp\left(-\sum_{m \geq 1} \frac{1}{m} a_i(m) z^m\right) \text{ and } \exp\left(-\sum_{m \geq 1} \frac{1}{m} a_i(-m) z^m\right).$$

Our defining relations above are a t -deformation of the relations between these homogeneous components. Moreover, since the representations of \mathfrak{h}_Γ we consider in this paper are all of level 1, so that c acts by 1, we have also found it convenient to replace c by 1 in the definition of \mathfrak{h}_Γ .

The version of the Heisenberg algebra we use is actually an idempotent modification of \mathfrak{h}_Γ (this is similar to the appearance of idempotent versions of $U_q(\mathfrak{g})$ in the categorification of quantum groups [KL], [R]). In the idempotent modification, the unit 1 is replaced by a collection of orthogonal idempotents $\{1_m\}_{m \in \mathbb{Z}}$, with

$$1_{k+m} p_i^{(m)} = p_i^{(m)} 1_k = \delta_{k+m, n} 1_n p_i^{(m)} 1_k$$

and

$$1_{k-m}q_i^{(m)} = q_i^{(m)}1_k = \delta_{k-m,n}1_nq_i^{(m)}1_k.$$

The remaining defining relations in the unital algebra h_Γ give, for each $k \in \mathbb{Z}$, a defining relation of the idempotent modification. Namely, take the original relation and add the idempotent 1_k at the end of the left and right hand side, e.g.

$$q_i^{(n)}p_j^{(m)}1_k = p_j^{(m)}q_i^{(n)}1_k \text{ for all } i \neq j \in I_\Gamma \text{ with } \langle i, j \rangle = 0 \text{ and all } k \in \mathbb{Z}.$$

Note that these relations do not depend essentially on the particular idempotent 1_k . As a result, we abuse notation slightly and also denote both the unital algebra and its idempotent modification by \mathfrak{h}_Γ . One feature of the idempotent-modified \mathfrak{h}_Γ is that it can be considered as a $\mathbb{k}[t, t^{-1}]$ -linear category (just as any \mathbb{k} -algebra with a collection of idempotents can be considered as a \mathbb{k} -linear category.) The objects of this category are then the integers, while the space of morphisms from n to m is the $\mathbb{k}[t, t^{-1}]$ module $1_n\mathfrak{h}_\Gamma 1_m$. Since \mathfrak{h}_Γ is already a category, its categorification \mathcal{H}_Γ defined in section 3 will be a 2-category.

2.3. The Fock space. Let $\mathfrak{h}_\Gamma^- \subset \mathfrak{h}_\Gamma$ denote the subalgebra generated by the $q_i^{(n)}1_k$ for all $i \in I_\Gamma$, $k \leq 0$ and $n \geq 0$. Let triv_0 denote the trivial representation of \mathfrak{h}_Γ^- , where 1_0 acts by the identity and 1_k acts by 0 for $k < 0$. The \mathfrak{h}_Γ^- module $\mathcal{F}_\Gamma = \text{Ind}_{\mathfrak{h}_\Gamma^-}^{\mathfrak{h}_\Gamma}(\text{triv}_0)$ given by inducing the trivial representation from \mathfrak{h}_Γ^- to \mathfrak{h}_Γ is called the Fock space representation of \mathfrak{h}_Γ .

The Fock space \mathcal{F}_Γ is naturally isomorphic to the space of polynomials in the commuting variables $\{p_j^{(m)}\}_{j \in I_\Gamma, m \geq 0}$. If we grade the Fock space by declaring $\deg(p_j^{(m)}) = m$ then the idempotent $1_l \in \mathfrak{h}_\Gamma$ acts by projecting onto the degree l subspace inside $\mathcal{F}_\Gamma \cong \mathbb{k}[\{p_j^{(m)}\}_{j,m}]$ (in particular, when $l < 0$ the idempotent 1_l acts by 0.) We will construct categorifications of this representation in sections 4 and 8.

3. THE CATEGORY \mathcal{H}_Γ

3.1. The algebra B^Γ . To define the 2-category \mathcal{H}_Γ which categorifies \mathfrak{h}_Γ we first need to define the algebra B^Γ and fix notation involving idempotents in this algebra.

Since Γ acts on V it also acts on the exterior algebra $\Lambda^*(V)$. Let $B^\Gamma := \Lambda^*(V) \rtimes \Gamma$ be their semi-direct product, which contains both $\Lambda^*(V)$ and $\mathbb{k}[\Gamma]$ as subalgebras. This semi-direct product is also called the smash product of $\mathbb{k}[\Gamma]$ and $\Lambda^*(V)$, and is sometimes denoted $\Lambda^*(V) \# \mathbb{k}[\Gamma]$ in Hopf algebra literature, though we prefer the term semi-direct product and avoid the $\#$ notation.

Explicitly, an element in B^Γ is a linear combination of terms (v, γ) where $v \in \Lambda^*(V)$ and $\gamma \in \Gamma$. The multiplication in B^Γ is given by

$$(v, \gamma) \cdot (v', \gamma') = (v \wedge (\gamma \cdot v'), \gamma\gamma').$$

The natural \mathbb{Z} grading on $\Lambda^*(V)$ extends to a grading of B^Γ by putting $\mathbb{k}[\Gamma] \subset B^\Gamma$ in degree zero. This makes B^Γ into a superalgebra. We denote the degree of an element $b \in B^\Gamma$ by $|b|$.

If we fix a basis $\{v_1, v_2\}$ of V and let $\omega := v_1 \wedge v_2 \in \Lambda^2(V)$ then B^Γ has a homogeneous basis over \mathbb{k} given by $\{(1, \gamma), (v_1, \gamma), (v_2, \gamma), (\omega, \gamma)\}_{\gamma \in \Gamma}$.

Define a \mathbb{k} -linear trace $\text{tr} : B^\Gamma \rightarrow \mathbb{k}$ by setting

$$\text{tr}((\omega, \gamma)) = \delta_{\gamma, 1} \text{ and } \text{tr}((1, \gamma)) = \text{tr}((v_1, \gamma)) = \text{tr}((v_2, \gamma)) = 0.$$

The trace tr is supersymmetric (for any $a, b \in B^\Gamma$ we have $\text{tr}(ab) = (-1)^{|a||b|}\text{tr}(ba)$) and non-degenerate. This also induces a trace on $\mathbb{k}[\Gamma]$ via $\text{tr}(\gamma) := \text{tr}((\omega, \gamma))$. This corresponds to the usual trace on $\mathbb{k}[\Gamma]$ divided by $|\Gamma|$ (in this way $\text{tr}(1) = 1$).

For a fixed \mathbb{k} -basis \mathcal{B} of B^Γ , let \mathcal{B}^\vee denote the basis of B^Γ dual to \mathcal{B} with respect to the associated non-degenerate bilinear form $\langle a, b \rangle := \text{tr}(ab)$. We denote the dual vector of $b \in \mathcal{B}$ by $b^\vee \in \mathcal{B}$.

Remark 3.1. We may think of elements of B^Γ as $\mathbb{k}[\Gamma]$ -module homomorphisms,

$$B^\Gamma \cong \text{Hom}_{\mathbb{k}[\Gamma]}(\mathbb{k}[\Gamma], \Lambda^*(V) \otimes \mathbb{k}[\Gamma]).$$

The above isomorphism is given by the following composition

$$\begin{aligned} B^\Gamma &\cong \text{Hom}_{B^\Gamma}(B^\Gamma, B^\Gamma) \cong \text{Hom}_{B^\Gamma}(\text{Ind}_{\mathbb{k}[\Gamma]}^{B^\Gamma} \mathbb{k}[\Gamma], B^\Gamma) \cong \text{Hom}_{\mathbb{k}[\Gamma]}(\mathbb{k}[\Gamma], \text{Res}_{B^\Gamma}^{\mathbb{k}[\Gamma]} B^\Gamma) \\ &\cong \text{Hom}_{\mathbb{k}[\Gamma]}(\mathbb{k}[\Gamma], \Lambda^*(V) \otimes \mathbb{k}[\Gamma]). \end{aligned}$$

3.1.1. *Idempotents.* Let V_1, \dots, V_m denote the distinct irreducible representations of Γ . By Maschke's theorem, the group algebra $\mathbb{k}[\Gamma]$ decomposes as a direct product of matrix algebras

$$\mathbb{k}[\Gamma] = M_{n_1}(\mathbb{k}) \times \dots \times M_{n_m}(\mathbb{k})$$

where the distinct irreducible representations V_1, \dots, V_m are each realized as an irreducible representation of one of the matrix algebras $M_{n_i}(\mathbb{k})$. Let f_1, \dots, f_m denote the distinct pairwise orthogonal central idempotents of $\mathbb{k}[\Gamma]$; each f_i is the identity matrix in the matrix algebra $M_{n_i}(\mathbb{k})$, and

$$1 = \sum_i f_i \in \mathbb{k}[\Gamma].$$

The above is not, in general, a minimal decomposition of 1 as a sum of orthogonal idempotents, since the idempotents f_i themselves are not minimal if $\dim(V_i) > 1$. For each i and $s = 1, \dots, n_i$, let $e_{i,s}$ denote the matrix unit of $M_{n_i}(\mathbb{k})$ whose (s, s) entry is equal to 1 and whose other entries are 0. Then the $e_{i,s}$ are minimal orthogonal idempotents in $\mathbb{k}[\Gamma]$, with

$$f_i = \sum_{s=1}^{n_i} e_{i,s}.$$

An important role will be played by the (super)algebra

$$B_n^\Gamma := (B^\Gamma \otimes \dots \otimes B^\Gamma) \rtimes S_n.$$

The above tensor product is understood in the super sense, and the action of S_n is by superpermutations: if $s_k \in S_n$ is the simple transposition $(k, k+1)$, then

$$s_k \cdot (b_1 \otimes \dots \otimes b_k \otimes b_{k+1} \otimes \dots \otimes b_n) = (-1)^{|b_k||b_{k+1}|} b_1 \otimes \dots \otimes b_{k+1} \otimes b_k \otimes \dots \otimes b_n.$$

The degree zero subalgebra $\mathbb{k}[\Gamma^n \rtimes S_n] \subset B_n^\Gamma$ contains all the idempotents of B_n^Γ . This subalgebra is isomorphic to a direct product of matrix algebras

$$\mathbb{k}[\Gamma^n \rtimes S_n] = M_{l_1}(\mathbb{k}) \times \dots \times M_{l_s}(\mathbb{k})$$

with one matrix algebra for each isomorphism class of irreducible $\mathbb{k}[\Gamma^n \rtimes S_n]$ -module. Just as the isomorphism classes of irreducible $\mathbb{k}[S_n]$ -modules are parametrized by partitions of n the isomorphism classes of irreducible $\mathbb{k}[\Gamma^n \rtimes S_n]$ -modules are parametrized by partition-valued functions of I_Γ (i.e. $|I_\Gamma|$ -tuples of partitions of n).

3.2. **The category \mathcal{H}'_Γ .** We define an additive, \mathbb{k} -linear, \mathbb{Z} -graded 2-category \mathcal{H}'_Γ as follows. The objects of \mathcal{H}'_Γ are indexed by the integers \mathbb{Z} . The 1-morphisms are generated by P and Q , where for each n , P denotes a 1-morphism from n to $n+1$ and Q is a 1-morphism from $n+1$ to n . Thus a 1-morphism of \mathcal{H}'_Γ is a finite composition (sequence) of P 's and Q 's. The identity 1-morphism of n is denoted $\mathbf{1}$ (the empty sequence).

Remark 3.2. Technically we should write $P(n)$ and $(n)Q$ to identify the domain and range of P and Q . However, the properties of P and Q do not depend on n so we usually omit this extra parameter in order to simplify notation. We could have chosen to define \mathcal{H}'_Γ as a monoidal 1-category instead of as a 2-category, but we prefer to consider \mathcal{H}'_Γ as a 2-category because this better parallels the story for Kac-Moody Lie algebras in [KL, R].

The space of 2-morphisms between two 1-morphisms is a \mathbb{Z} -graded \mathbb{k} -algebra generated by suitable planar diagrams modulo local relations. The diagrams consist of oriented compact one-manifolds immersed into the plane strip $\mathbb{R} \times [0, 1]$ modulo isotopies fixing the boundary.

A single upward oriented strand denotes the identity 2-morphism $\text{id} : P \rightarrow P$ while a downward oriented strand denotes the identity 2-morphism $\text{id} : Q \rightarrow Q$.



An upward-oriented line is allowed to carry dots labeled by elements $b \in B^\Gamma$. For example,



is an element of $\text{Hom}_{\mathcal{H}_\Gamma}(P, P)$, while



is an element of $\text{Hom}_{\mathcal{H}_\Gamma}(PQ, QP)$. Note that the domain of a 2-morphism is specified at the bottom of the diagram and the codomain is specified at the top, and compositions of 2-morphisms are read from bottom to top.

The local relations we impose are the following. First we have relations involving the movement of dots along the carrier strand. We allow dots to move freely along strands and through intersections:

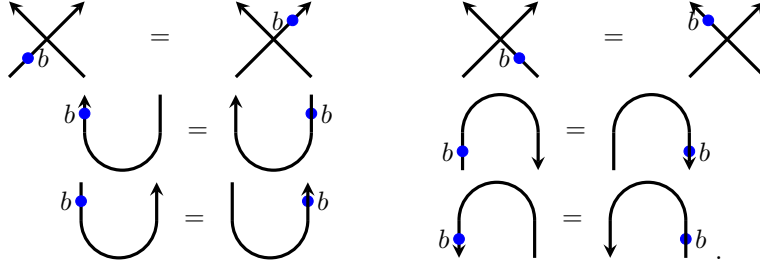

The U-turn 2-morphisms are adjunctions making P and Q biadjoint up to a grading shift that will be defined later in this section. Collision of dots is controlled by multiplication in the algebra B^Γ :



Note that dots compose, so to speak, in the direction of the arrow.

Dots on distinct strands supercommute when they move past one another:

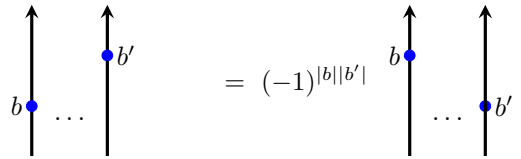

In addition to specifying how dots collide and slide we impose the following local relations in the Γ graphical calculus:

$$(6) \quad \begin{array}{ccc} \begin{array}{c} \nearrow \searrow \\ \searrow \nearrow \end{array} & = & \begin{array}{c} \nearrow \nearrow \\ \searrow \searrow \end{array} \end{array} \quad \begin{array}{ccc} \begin{array}{c} \nearrow \searrow \\ \searrow \nearrow \end{array} & = & \begin{array}{c} \uparrow \uparrow \\ \uparrow \uparrow \end{array} \end{array}$$

$$(7) \quad \begin{array}{ccc} \begin{array}{c} \nearrow \searrow \\ \searrow \nearrow \end{array} & = & \begin{array}{c} \uparrow \\ \uparrow \end{array} \end{array} \quad \begin{array}{ccc} \begin{array}{c} \uparrow \\ \uparrow \end{array} & - \sum_{b \in \mathcal{B}} \begin{array}{c} \begin{array}{c} \curvearrowright \\ \bullet \\ \curvearrowleft \end{array} \\ \begin{array}{c} \bullet \\ \curvearrowleft \\ \curvearrowright \end{array} \end{array} & & \begin{array}{ccc} \begin{array}{c} \nearrow \searrow \\ \searrow \nearrow \end{array} & = & \begin{array}{c} \uparrow \\ \downarrow \end{array} \end{array}$$

$$(8) \quad \begin{array}{ccc} \begin{array}{c} \curvearrowright \\ \bullet \end{array} & = & \text{tr}(b). \end{array} \quad \begin{array}{ccc} \begin{array}{c} \curvearrowright \\ \uparrow \end{array} & = & 0. \end{array}$$

In the first equation on line 7 above, the summation is taken over a basis \mathcal{B} of B^Γ — this morphism is easily seen to be independent of the choice of basis. We assign a \mathbb{Z} -grading on the space of planar diagrams by defining

$$\begin{array}{ccc} \text{deg} \begin{array}{c} \nearrow \searrow \\ \searrow \nearrow \end{array} & = & 0 \\ \text{deg} \begin{array}{c} \curvearrowright \\ \uparrow \end{array} & = & \text{deg} \begin{array}{c} \curvearrowleft \\ \downarrow \end{array} = -1 \\ \text{deg} \begin{array}{c} \curvearrowleft \\ \uparrow \end{array} & = & \text{deg} \begin{array}{c} \curvearrowright \\ \downarrow \end{array} = 1 \end{array}$$

and by defining the degree of a dot labeled by b to be the degree of b in the graded algebra B^Γ . When equipped with these assignments all of the graphical relations are graded. Thus $\text{Hom}_{\mathcal{H}_T^\Gamma}(\cdot, \cdot)$ is a \mathbb{Z} -graded vector space and composition of morphisms is compatible with the grading.

Because of the relation dictating how dots slide through crossings, there is a natural map from the semidirect product

$$B_n^\Gamma := (B^\Gamma \otimes \cdots \otimes B^\Gamma) \rtimes S_n$$

to the endomorphism algebra $\text{Hom}_{\mathcal{H}_T^\Gamma}(P^n, P^n)$ whose image is the subalgebra spanned by braid-like diagrams (i.e. diagrams with no local maxima or local minima). Notice that, if we denote by T_k upward crossings of the k and $(k+1)$ st adjacent strands and by $X_k(b)$ dots labeled $b \in B^\Gamma$ on the k th strand then this subalgebra is generated by T_1, \dots, T_{n-1} and $X_1(b), \dots, X_n(b)$ for $b \in B^\Gamma$. The T s and X s are subject to the following relations:

$$\begin{aligned} T_k^2 &= 1 \text{ and } T_k T_l = T_l T_k \text{ for } |k-l| > 1, \\ T_k T_{k+1} T_k &= T_{k+1} T_k T_{k+1} \text{ for all } k = 1, \dots, n-2 \\ T_k X_k(b) &= X_{k+1}(b) T_k \text{ for all } k = 1, \dots, n-1. \\ X_k(b) X_k(b') &= X_k(bb') \text{ and } X_k(b) X_l(b') = (-1)^{|b||b'|} X_l(b') X_k(b) \text{ if } k \neq l. \end{aligned}$$

We will write T and $X(b)$ instead of T_k and $X_k(b)$ when the subscript is understood. In fact, it will follow from the construction of section 8 that the map $B_n^\Gamma \rightarrow \text{End}_{\mathcal{H}'_\Gamma}(P^n)$ is injective, so that the subspace of endomorphisms spanned by braid-like diagrams is isomorphic B_n^Γ (see Remark 9.1).

3.3. The category \mathcal{H}_Γ . We define \mathcal{H}_Γ to be the Karoubi envelope (also known as the idempotent completion) of \mathcal{H}'_Γ . By definition, the objects of \mathcal{H}_Γ are also indexed by \mathbb{Z} while a 1-morphism consists of a pair (R, e) where R is a 1-morphism of \mathcal{H}'_Γ and $e : R \rightarrow R$ is an idempotent endomorphism $e^2 = e$. Morphisms from (R, e) to (R', e') are morphisms $g : R \rightarrow R'$ such that $ge = g$ and $e'g = g$. The idempotent e defines the identity morphism of (R, e) .

Since \mathcal{H}_Γ is a graded 2-category, the (split) Grothendieck group $K_0(\mathcal{H}_\Gamma)$ of \mathcal{H}_Γ is a $\mathbb{k}[q, q^{-1}]$ -linear category where multiplication by q corresponds to the shift $\langle 1 \rangle$ (we will assume Grothendieck groups are tensored with the base field \mathbb{k}). The objects of $K_0(\mathcal{H}_\Gamma)$ are the same as the objects of \mathcal{H}_Γ , namely the integers. The space of morphisms $\text{Hom}_{K_0(\mathcal{H}_\Gamma)}(n, m)$ is the split Grothendieck group of the additive category $\text{Hom}_{\mathcal{H}_\Gamma}(n, m)$. Composition of 1-morphisms in \mathcal{H}_Γ gives the Grothendieck group $K_0(\mathcal{H}_\Gamma)$ the structure of a \mathbb{k} -algebra.

3.4. Main Theorem #1. The first main theorem of this paper is that \mathcal{H}_Γ categorifies \mathfrak{h}_Γ :

Theorem 1. *There is a canonical isomorphism of algebras*

$$\pi : \mathfrak{h}_\Gamma \xrightarrow{\sim} K_0(\mathcal{H}_\Gamma).$$

This theorem will be proven in Section 7. In the rest of this section we want to sketch how the morphism π comes about.

To do this consider various idempotent 2-morphisms in the category \mathcal{H}'_Γ . Since $M_{n_i}(\mathbb{k}) \subset \mathbb{k}[\Gamma] \subset B^\Gamma \subset \text{End}_{\mathcal{H}'_\Gamma}(P)$, any idempotent $e \in M_{n_i}(\mathbb{k})$ gives rise (for any $n \in \mathbb{Z}$) to a 1-morphism (P, e) in $\text{Hom}_{\mathcal{H}_\Gamma}(n, n+1)$. Let $\tilde{P}_i = (P, f_i) \in \mathcal{H}_\Gamma$, where the f_i are the pairwise orthogonal central idempotents of $\mathbb{C}[\Gamma]$ described in section 3.1.1.

Lemma 1. *There is an isomorphism of 1-morphisms in the category \mathcal{H}_Γ*

$$P \cong \bigoplus_{i=1}^m \tilde{P}_i$$

Proof. The idempotents f_i define a 2-morphism from $\bigoplus_{i=1}^m \tilde{P}_i$ to P in \mathcal{H}_Γ . Since $1 = \sum_{i=1}^m f_i$ and $f_i f_j = \delta_{i,j} f_i$, this 2-morphism is an isomorphism. \square

The 1-morphisms \tilde{P}_i can be further decomposed in \mathcal{H}_Γ whenever the idempotents f_i are not minimal. Recall the minimal idempotents $e_{i,1}, \dots, e_{i,n_i}$ from section 3.1.1. Note that for fixed i the $e_{i,j}$, which are distinct idempotents in $M_{n_i}(\mathbb{k})$, define isomorphic representations $\mathbb{C}[\Gamma]e_{i,1} \cong \mathbb{C}[\Gamma]e_{i,l}$ of $\mathbb{C}[\Gamma]$. In particular, the objects $(P, e_{i,j})$ for distinct j are all isomorphic in \mathcal{H}_Γ . Let P_i denote the 1-morphism $(P, e_{i,1}) \in \mathcal{H}_\Gamma$. Then we have the following

Lemma 2. *There is an isomorphism in \mathcal{H}_Γ*

$$\tilde{P}_i \cong \bigoplus_{j=1}^{n_i} P_i^{\oplus n_i}$$

where n_i is the dimension (as a \mathbb{k} vector space) of the $\mathbb{k}[\Gamma]$ -module V_i .

Proof. The proof is just as in Lemma 1 using the fact that $f_i = \sum_{j=1}^{n_i} e_{i,j}$. \square

We will prove later in section 7 that the objects $P_i \in \mathcal{H}_\Gamma$ are indecomposable.

The canonical adjunctions in \mathcal{H}'_Γ involving P and Q (the cups and caps) also allow us to decompose Q , since any idempotent $e \in \text{End}_{\mathcal{H}'_\Gamma}(P)$ gives rise to an idempotent $e \in \text{End}_{\mathcal{H}'_\Gamma}(Q)$. We define 1-morphisms $Q_i \in \mathcal{H}_\Gamma$ by $Q_i = (Q, e_{i,1})$. It follows immediately by adjunction that Q_i is indecomposable too.

A basic consequence of the relations between 2-morphisms in \mathcal{H}_Γ is the following result proved in section 6.

Proposition 1. *For $i, j \in I_\Gamma$, we have*

$$Q_j P_i \cong \begin{cases} P_i Q_j \oplus \text{id}\langle -1 \rangle \oplus \text{id}\langle 1 \rangle & \text{if } i = j, \\ P_i Q_j \oplus \text{id}^{\oplus k} & \text{if } i \neq j \text{ are connected by } k \geq 0 \text{ edges} \end{cases}$$

where $\langle \cdot \rangle$ denotes the grading shift in \mathcal{H}_Γ .

More generally, we define 1-morphisms $P_i^{(n)}$ and $Q_i^{(n)}$ by

$$P_i^{(n)} = (P^n, e_{\text{triv},i,1}) \text{ and } Q_i^{(n)} = (Q^n, e_{\text{triv},i,1})$$

where the idempotent $e_{\text{triv},i,1}$ is a minimal idempotent in $M_{n_i}(\mathbb{k})^n \rtimes S_n \subset \mathbb{k}[\Gamma^n \rtimes S_n]$ corresponding to the trivial representation of S_n . In section 6 we prove the following proposition.

Proposition 2. *For $i, j \in I_\Gamma$ we have isomorphisms in \mathcal{H}_Γ :*

$$\begin{aligned} P_i^{(n)} P_j^{(m)} &\cong P_j^{(m)} P_i^{(n)} \text{ for all } i, j \in I_\Gamma, \\ Q_i^{(n)} Q_j^{(m)} &\cong Q_j^{(m)} Q_i^{(n)} \text{ for all } i, j \in I_\Gamma, \\ Q_i^{(n)} P_i^{(m)} &\cong \bigoplus_{k \geq 0} P_i^{(m-k)} Q_i^{(n-k)} \otimes H^*(\mathbb{P}^k) \text{ for all } i \in I_\Gamma, \\ Q_i^{(n)} P_j^{(m)} &\cong \bigoplus_{k \geq 0} P_j^{(m-k)} Q_i^{(n-k)} \text{ for all } i \neq j \in I_\Gamma \text{ with } \langle i, j \rangle = -1, \\ Q_i^{(n)} P_j^{(m)} &\cong P_j^{(m)} Q_i^{(n)} \text{ for all } i \neq j \in I_\Gamma \text{ with } \langle i, j \rangle = 0 \end{aligned}$$

where $H^*(\mathbb{P}^k)$ denotes the graded cohomology of projective spaces \mathbb{P}^k shifted so that it lies in in degrees $-k, -k+2, \dots, k-2, k$.

Notice that in the third equation above the graded dimension of $H^*(\mathbb{P}^k)$ is the quantum integer $[k+1]$. By convention $H^*(\mathbb{P}^k) = 0$ if $k < 0$. Also, $P_i^{(l)} = Q_i^{(l)} = 0$ when $l < 0$ so the summand corresponding to a $k > \min(n, m)$ is zero (so the direct sum on the right is finite).

It follows immediately from Proposition 2 that there is a well-defined morphism

$$\pi : \mathfrak{h}_\Gamma \longrightarrow K_0(\mathcal{H}_\Gamma)$$

given by sending $p_i^{(n)}$ to the class $[P_i^{(n)}]$ and sending $q_j^{(m)}$ to the class $[Q_j^{(m)}]$. That the map π is an isomorphism is a rigorous formulation of the informal statement “ \mathcal{H}_Γ categorifies the Heisenberg algebra.”

3.5. Remarks on relations in \mathcal{H}'_Γ . We end this section with some remarks on the relations from lines (6) - (8). The second relation in (8) is natural for degree reasons; in fact imposing this relation is equivalent to declaring that the object P does not have negative degree endomorphisms.

Moreover, if we believe that the identity should not have negative degree endomorphisms then the left relation in (8) is immediate unless a has degree 2, that is, unless a is a linear combination of elements of the form $(v_1 \wedge v_2, \gamma)$. Since

$$(v_1 \wedge v_2, \gamma) = (v_1, \gamma) \cdot (\gamma^{-1} v_2, 1),$$

from moving $\gamma^{-1}v_2$ around the circle we get

$$(v_1 \wedge v_2, \gamma) \cdot \text{circle} = (-\gamma^{-1}v_2 \wedge v_1, \gamma) \cdot \text{circle}$$

where the minus sign is a consequence of passing the dot labeled (v_1, γ) by the dot labeled $(\gamma^{-1}v_2, 1)$. Since γ acts nontrivially on V , it follows that the counterclockwise circle with a solid dot labeled by $(v_1 \wedge v_2, \gamma)$ is zero unless $\gamma = 1$.

To understand the relation imposed when $\gamma = 1$, we add a cup at the bottom of the first relation in (7). Simplifying, we obtain

$$\uparrow = v_1 \wedge v_2 \cdot \text{circle} \uparrow$$

It follows that if the closed diagram which appears above is a scalar then it must be equal to one. Alternatively, if we multiply the upward strand by $v_1 \wedge v_2$ and close off we get that the counterclockwise circle with a solid dot labeled by $v_1 \wedge v_2$ is an idempotent. So, if this idempotent were not equal to one, then the identity map would break up into a direct sum of multiple 1-morphisms in the idempotent completion. This would result in extra unwanted 1-morphisms in our Heisenberg category \mathcal{H}_Γ .

3.5.1. *Further relations.* Although left-twist curls on an upward pointing strand are zero right-twist curls (which have degree 2) and are not necessarily zero. As shorthand, we will draw right twist curls as hollow dots:

$$\uparrow \text{ (hollow dot) } := \uparrow \text{ (right twist curl) }$$

To pass a solid dot past a hollow dot involves sliding the solid dot along the right-twist curl. Thus solid dots transform commute with hollow dots

$$\uparrow \text{ (solid dot) } \text{ (hollow dot) } = \uparrow \text{ (hollow dot) } \text{ (solid dot) }$$

Hollow dots have an interesting ‘‘affine Hecke’’ type relation with crossings which involves the creation of labeled solid dots,

$$\begin{aligned} \text{crossing (hollow dot on left)} &= \text{crossing (hollow dot on right)} + \sum_{b \in \mathcal{B}} \uparrow \text{ (solid dot } b) \uparrow \text{ (solid dot } b^\vee) \\ \text{crossing (hollow dot on right)} &= \text{crossing (hollow dot on left)} + \sum_{b \in \mathcal{B}} \uparrow \text{ (solid dot } b) \uparrow \text{ (solid dot } b^\vee) \end{aligned}$$

where again the summations are over the basis \mathcal{B} . These relations are reminiscent of relations in the degenerate affine Hecke algebra associated to the symmetric group and its wreath products, see for instance [RS, W, WW]. The proof of these relations is an easy calculation using the defining relations for 2-morphisms in \mathcal{H}'_Γ .

Finally, it also follows directly from the graphical relations that the triple point move,

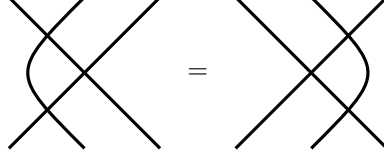

which was defined to hold when all three strands are oriented up, in fact holds in all possible orientations.

4. ACTION OF \mathcal{H}_Γ

In this section we construct an action of \mathcal{H}_Γ on the derived categories of finite dimensional graded modules over certain algebras A_n^Γ . This induces an action on derived categories of coherent sheaves on Hilbert schemes and allows us to show in the next section that our categories \mathcal{H}_Γ are non-degenerate (subsequently proving Theorem 1).

4.1. Categories. Since $\Gamma \subset SL_2(\mathbb{k})$ acts on $V \cong \mathbb{k}^2$ it acts naturally on $\text{Sym}^*(V^\vee)$ and we denote by $\text{Sym}^*(V^\vee) \rtimes \Gamma$ their semi-direct product (also known as the smash product $\text{Sym}^*(V^\vee) \# \mathbb{k}[\Gamma]$). For instance, if $\Gamma = \mathbb{Z}/n\mathbb{Z}$ then we can identify $\text{Sym}^*(V^\vee)$ with $\mathbb{k}[x, y]$ and the action is $\zeta \cdot (x, y) = (\zeta x, \zeta^{-1}y)$. $\text{Sym}^*(V^\vee) \rtimes \Gamma$ is a \mathbb{k} -algebra, and an element of $\text{Sym}^*(V^\vee) \rtimes \Gamma$ is a linear combination of elements of the form (f, γ) where $f \in \text{Sym}^*(V^\vee)$ and $\gamma \in \Gamma$ with multiplication given by

$$(f, \gamma) \cdot (f', \gamma') = (f\gamma \cdot f', \gamma\gamma').$$

For each non-negative integer n define

$$A_n^\Gamma := [(\text{Sym}^*(V^\vee) \rtimes \Gamma) \otimes (\text{Sym}^*(V^\vee) \rtimes \Gamma) \otimes \cdots \otimes (\text{Sym}^*(V^\vee) \rtimes \Gamma)] \rtimes S_n$$

where S_n is the symmetric group acting by permuting the n terms in the product. Notice that here we use the ordinary tensor product and not the super tensor product used to define B_n^Γ . These algebras inherit the natural grading from $\text{Sym}^*(V^\vee)$. We denote by $D(A_n^\Gamma\text{-gmod})$ the bounded derived category of finite dimensional, graded (left) A_n^Γ -modules.

We have maps

$$\mathbb{k}[\Gamma] \xrightarrow{i} A_1^\Gamma \xrightarrow{p} \mathbb{k}[\Gamma]$$

where the first denotes the natural inclusion of the group algebra $\mathbb{k}[\Gamma]$ and the second is the projection which takes $\text{Sym}^{>0}(V)$ to zero. Thus any $\mathbb{k}[\Gamma]$ -module is also an A_1^Γ -module and vice versa.

4.2. Functors P and Q. Consider the natural inclusion $A_n^\Gamma \otimes A_1^\Gamma \rightarrow A_{n+1}^\Gamma$ making use of the embedding $S_n = S_n \times S_1 \hookrightarrow S_{n+1}$. This gives A_{n+1}^Γ and $A_n^\Gamma \otimes \mathbb{k}[\Gamma]$ the structure of a module over $A_n^\Gamma \otimes A_1^\Gamma$.

Define the $(A_{n+1}^\Gamma, A_n^\Gamma)$ bimodule

$$P^\Gamma(n) := A_{n+1}^\Gamma \otimes_{A_n^\Gamma \otimes A_1^\Gamma} (A_n^\Gamma \otimes \mathbb{k}[\Gamma])$$

and the $(A_n^\Gamma, A_{n+1}^\Gamma)$ bimodule

$$(n)Q^\Gamma := (A_n^\Gamma \otimes \mathbb{k}[\Gamma]) \otimes_{A_n^\Gamma \otimes A_1^\Gamma} A_{n+1}^\Gamma.$$

Define the functor $P(n) : D(A_n^\Gamma\text{-gmod}) \rightarrow D(A_{n+1}^\Gamma\text{-gmod})$ by

$$P(n)(\cdot) := P^\Gamma(n) \otimes_{A_n^\Gamma} (\cdot).$$

Similarly, we define $(n)Q : D(A_{n+1}^\Gamma\text{-gmod}) \rightarrow D(A_n^\Gamma\text{-gmod})$ by

$$(n)Q(\cdot) := (n)Q^\Gamma \otimes_{A_{n+1}^\Gamma} (\cdot)[-1]\{1\}$$

where $[\cdot]$ denotes the cohomological shift while $\{\cdot\}$ the grading shift. Note that the relation between these shifts and the shift $\langle \cdot \rangle$ in \mathcal{H}_Γ is that $\langle 1 \rangle = [1]\{-1\}$. We will usually omit the (n) and just write P or Q .

4.3. Natural transformations. In order to define an \mathcal{H}_Γ action on $\oplus_n D(A_n^\Gamma\text{-gmod})$ we also need to define the following natural transformations:

- (1) $X(v) : P \rightarrow P[1]\{-1\}$ and $X(v) : Q \rightarrow Q[1]\{-1\}$ for any $v \in V$
- (2) $X(\gamma) : P \rightarrow P$ and $X(\gamma) : Q \rightarrow Q$ for any $\gamma \in \Gamma$
- (3) $T : PP \rightarrow PP$, $T : QQ \rightarrow QQ$, $T : QP \rightarrow PQ$ and $T : PQ \rightarrow QP$
- (4) $\text{adj} : QP \rightarrow \text{id}[-1]\{1\}$ and $\text{adj} : PQ \rightarrow \text{id}[1]\{-1\}$
- (5) $\text{adj} : \text{id} \rightarrow QP[-1]\{1\}$ and $\text{adj} : \text{id} \rightarrow PQ[1]\{-1\}$.

These natural transformations define the action of the following 2-morphisms in \mathcal{H}'_Γ (as usual we read the diagrams from the bottom up):

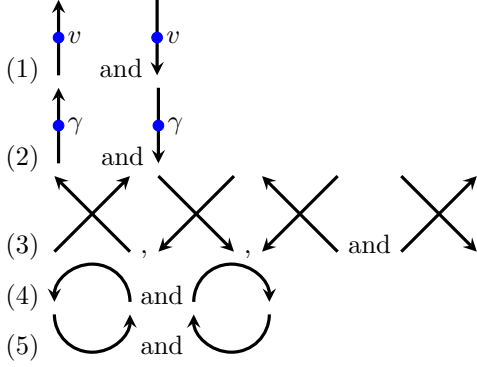

4.3.1. Preliminaries. Since we will deal with tensor products of complexes we briefly review some standard conventions. Given two complexes

$$A_\bullet = \cdots \rightarrow A_i \xrightarrow{d} A_{i+1} \rightarrow \cdots \text{ and } B_\bullet = \cdots \rightarrow B_i \xrightarrow{d} B_{i+1} \rightarrow \cdots$$

the tensor product $A_\bullet \otimes B_\bullet$ is the complex with terms $A_i \otimes B_j$ and differential

$$A_i \otimes B_j \xrightarrow{d \otimes 1 + (-1)^i 1 \otimes d} A_{i+1} \otimes B_j \oplus A_i \otimes B_{j+1}.$$

Given a map $f : A_\bullet \rightarrow A_\bullet[k]$ of complexes induced by $f_i : A_i \rightarrow A_{i+k}$ we get a map $f \otimes 1 : A_\bullet \otimes B_\bullet \rightarrow A_\bullet \otimes B_\bullet[k]$ induced by

$$(f \otimes 1)_i = f_i \otimes 1 : A_i \otimes B_j \rightarrow A_{i+k} \otimes B_j.$$

Similarly, given a map $g : B_\bullet \rightarrow B_\bullet[k]$ induced by $g_i : B_i \rightarrow B_{i+k}$ we get a map $1 \otimes g$ induced by

$$(1 \otimes g)_i = (-1)^{ik} g_i \otimes 1 : A_i \otimes B_j \rightarrow A_i \otimes B_{j+k}.$$

Notice that if $k = 1$ then $(f \otimes 1)$ and $(1 \otimes g)$ anti-commute.

4.3.2. Definition of $X \in \text{End}(P)$. We define a map $X(\gamma) : \mathbb{k}[\Gamma] \rightarrow \mathbb{k}[\Gamma]$ of left A_1^Γ -modules via multiplication on the right $\gamma' \mapsto \gamma' \cdot \gamma$. This induces a map $X(\gamma) : P^\Gamma(n) \rightarrow P^\Gamma(n)$ of $(A_{n+1}^\Gamma, A_n^\Gamma)$ -bimodules.

To define $X(v)$ we have to work harder. Consider $A_1^\Gamma \otimes V^\vee$ where the tensor product is over \mathbb{k} (so A_1^Γ only acts on the left factor by multiplication on the left). Then the multiplication map $\text{Sym}^*(V^\vee) \otimes V^\vee \rightarrow \text{Sym}^*(V^\vee)$ induces a map $d : A_1^\Gamma \otimes V^\vee \rightarrow A_1^\Gamma$ of left A_1^Γ -modules via

$$(f, \gamma) \otimes w \mapsto (f\gamma \cdot w, \gamma)$$

where $f \in \text{Sym}^*(V)$, $\gamma \in \Gamma$ and $w \in V^\vee$. Similarly, we have a map $d : A_1^\Gamma \otimes \wedge^2 V^\vee \rightarrow A_1^\Gamma \otimes V^\vee$ given by

$$(f, \gamma) \otimes (w_1 \wedge w_2) \mapsto (f(\gamma w_1), \gamma) \otimes w_2 - (f(\gamma w_2), \gamma) \otimes w_1.$$

Using these maps we can define the following free resolution of the left A_1^Γ -module $\mathbb{k}[\Gamma]$:

$$(9) \quad 0 \rightarrow A_1^\Gamma \otimes \wedge^2 V^\vee \xrightarrow{d} A_1^\Gamma \otimes V^\vee \xrightarrow{d} A_1^\Gamma \rightarrow \mathbb{k}[\Gamma].$$

Suppose $v \in V$. We need to define a map $X(v) : \mathbb{k}[\Gamma] \rightarrow \mathbb{k}[\Gamma][1]\{-1\}$ inside $D(A_1^\Gamma\text{-gmod})$. To do this define

$$\phi_v : A_1^\Gamma \otimes V^\vee \rightarrow A_1^\Gamma\{-1\}$$

to be the map induced by $(f, \gamma) \otimes w \mapsto \langle w, v \rangle (f, \gamma)$, where $\langle \cdot, \cdot \rangle : V^\vee \otimes V \rightarrow \mathbb{k}$ is the natural pairing. It is easy to check this map is a map of graded left A_1^Γ -modules.

Similarly, define

$$\phi'_v : A_1^\Gamma \otimes \wedge^2 V^\vee \rightarrow A_1^\Gamma \otimes V^\vee\{-1\}$$

to be the map induced by

$$(f, \gamma) \otimes (w_1 \wedge w_2) \mapsto \langle w_1, v \rangle (f, \gamma) \otimes w_2 - \langle w_2, v \rangle (f, \gamma) \otimes w_1.$$

Using these maps we can write down the following commutative diagram

$$(10) \quad \begin{array}{ccccccc} 0 & \longrightarrow & A_1^\Gamma \otimes \wedge^2 V^\vee & \xrightarrow{d} & A_1^\Gamma \otimes V^\vee & \xrightarrow{d} & A_1^\Gamma \\ \downarrow & & \downarrow \phi'_v & & \downarrow \phi_v & & \downarrow \\ A_1^\Gamma \otimes \wedge^2 V^\vee\{-1\} & \xrightarrow{-d} & A_1^\Gamma \otimes V^\vee\{-1\} & \xrightarrow{-d} & A_1^\Gamma\{-1\} & \longrightarrow & 0 \end{array}$$

The commutativity of the middle square is an easy exercise (note that the differential is $-d$ in the second row since shifting the complex by one negates the differential).

The map from (10) induces a map $X(v) : \mathbb{k}[\Gamma] \rightarrow \mathbb{k}[\Gamma][1]\{-1\}$ and subsequently a map $X(v) : P^\Gamma(n) \rightarrow P^\Gamma(n)[1]\{-1\}$ (in the derived category) of graded $(A_{n+1}^\Gamma, A_n^\Gamma)$ -bimodules.

4.3.3. Definition of $X \in \text{End}(Q)$. If $\gamma \in \Gamma$ then multiplication on the left induces a map $X(\gamma) : \mathbb{k}[\Gamma] \rightarrow \mathbb{k}[\Gamma]$ of right A_1^Γ -modules via $\gamma' \mapsto \gamma \cdot \gamma'$ and subsequently a map $X(\gamma) : (n)Q^\Gamma \rightarrow (n)Q^\Gamma$ of $(A_n^\Gamma, A_{n+1}^\Gamma)$ -bimodules.

The map $X(v) : (n)Q^\Gamma \rightarrow (n)Q^\Gamma[1]\{-1\}$ is defined by using a resolution of Q^Γ as above. We consider $V^\vee \otimes A_1^\Gamma$ where A_1^Γ only acts on the second factor from the right. We have the maps

$$d : V^\vee \otimes A_1^\Gamma \rightarrow A_1^\Gamma \text{ and } d : \wedge^2 V^\vee \otimes A_1^\Gamma \rightarrow V^\vee \otimes A_1^\Gamma$$

of right A_1^Γ -modules via

$$w \otimes (f, \gamma) \mapsto (wf, \gamma) \text{ and } (w_1 \wedge w_2) \otimes (f, \gamma) \mapsto w_1 \otimes (w_2 f, \gamma) - w_2 \otimes (w_1 f, \gamma).$$

Using these maps we have a free resolution of the right A_1^Γ -module $\mathbb{k}[\Gamma]$ as in (9)

$$(11) \quad 0 \rightarrow \wedge^2 V^\vee \otimes A_1^\Gamma \xrightarrow{d} V^\vee \otimes A_1^\Gamma \xrightarrow{d} A_1^\Gamma \rightarrow \mathbb{k}[\Gamma].$$

Then we can write a map $X(v) : \mathbb{k}[\Gamma] \rightarrow \mathbb{k}[\Gamma][1]\{-1\}$ of graded right A_1^Γ -modules as in equation (10) except that we use the maps

$$\psi_v : V^\vee \otimes A_1^\Gamma \rightarrow A_1^\Gamma\{-1\} \text{ and } \psi'_v : \wedge^2 V^\vee \otimes A_1^\Gamma \rightarrow V^\vee \otimes A_1^\Gamma\{-1\}$$

given by

$$w \otimes (f, \gamma) \mapsto -\langle v, w \rangle (f, \gamma) \text{ and } (w_1 \wedge w_2) \otimes (f, \gamma) \mapsto \langle v, w_1 \rangle w_2 \otimes (f, \gamma) - \langle v, w_2 \rangle w_1 \otimes (f, \gamma).$$

Using these maps we can again write down the following commutative diagram

$$(12) \quad \begin{array}{ccccccc} 0 & \longrightarrow & \wedge^2 V^\vee \otimes A_1^\Gamma & \xrightarrow{d} & V^\vee \otimes A_1^\Gamma & \xrightarrow{d} & A_1^\Gamma \\ \downarrow & & \downarrow \psi'_v & & \downarrow \psi_v & & \downarrow \\ \wedge^2 V^\vee \otimes A_1^\Gamma\{-1\} & \xrightarrow{-d} & V^\vee \otimes A_1^\Gamma\{-1\} & \xrightarrow{-d} & A_1^\Gamma\{-1\} & \longrightarrow & 0. \end{array}$$

This induces a map $X(v) : \mathbb{k}[\Gamma] \rightarrow \mathbb{k}[\Gamma][1]\{-1\}$ and subsequently a map $X(v) : (n)Q^\Gamma \rightarrow (n)Q^\Gamma[1]\{-1\}$ (in the derived category) of graded $(A_n^\Gamma, A_{n+1}^\Gamma)$ -bimodules.

4.3.4. *Definition of $T \in \text{End}(P^2)$.* To define T we need a map

$$P^\Gamma(n+1) \otimes_{A_{n+1}^\Gamma} P^\Gamma(n) \rightarrow P^\Gamma(n+1) \otimes_{A_{n+1}^\Gamma} P^\Gamma(n).$$

Now

$$\begin{aligned} P^\Gamma(n+1) \otimes_{A_{n+1}^\Gamma} P^\Gamma(n) &\cong A_{n+2}^\Gamma \otimes_{A_{n+1}^\Gamma \otimes A_1^\Gamma} (A_{n+1}^\Gamma \otimes \mathbb{k}[\Gamma]) \otimes_{A_n^\Gamma \otimes A_1^\Gamma} (A_n^\Gamma \otimes \mathbb{k}[\Gamma]) \\ &\cong A_{n+2}^\Gamma \otimes_{A_n^\Gamma \otimes A_1^\Gamma \otimes A_1^\Gamma} (A_n^\Gamma \otimes \mathbb{k}[\Gamma] \otimes \mathbb{k}[\Gamma]) \\ &\cong A_{n+2}^\Gamma \otimes_{A_n^\Gamma \otimes A_2^\Gamma} A_n^\Gamma \otimes \left(A_2^\Gamma \otimes_{A_1^\Gamma \otimes A_1^\Gamma} \mathbb{k}[\Gamma] \otimes \mathbb{k}[\Gamma] \right). \end{aligned}$$

Now define a map $T : A_2^\Gamma \otimes_{A_1^\Gamma \otimes A_1^\Gamma} (\mathbb{k}[\Gamma] \otimes \mathbb{k}[\Gamma]) \rightarrow A_2^\Gamma \otimes_{A_1^\Gamma \otimes A_1^\Gamma} (\mathbb{k}[\Gamma] \otimes \mathbb{k}[\Gamma])$ by

$$(13) \quad a \otimes (\gamma \otimes \gamma') \mapsto a s_1 \otimes (\gamma' \otimes \gamma)$$

where $a \in A_2^\Gamma$ and $s_1 \in S_2$ is the transposition $(1, 2)$.

Let us check that this induces a well defined map. Suppose $a = (a', a'')$ where $a', a'' \in A_1^\Gamma$. Then

$$(14) \quad T(a \otimes (\gamma \otimes \gamma')) = T(1 \otimes (a' \cdot \gamma \otimes a'' \cdot \gamma')) = s_1 \otimes (a'' \gamma' \otimes a' \gamma).$$

On the other hand

$$(a', a'') s_1 \otimes (\gamma' \otimes \gamma) = s_1(a'', a') \otimes (\gamma' \otimes \gamma) = s_1 \otimes (a'' \gamma', a' \gamma)$$

which agrees with (14). This shows that T is well defined.

Notice that the induced map

$$T : A_{n+2}^\Gamma \otimes_{A_n^\Gamma \otimes A_1^\Gamma \otimes A_1^\Gamma} (A_n^\Gamma \otimes \mathbb{k}[\Gamma] \otimes \mathbb{k}[\Gamma]) \rightarrow A_{n+2}^\Gamma \otimes_{A_n^\Gamma \otimes A_1^\Gamma \otimes A_1^\Gamma} (A_n^\Gamma \otimes \mathbb{k}[\Gamma] \otimes \mathbb{k}[\Gamma])$$

is given by

$$1 \otimes (1 \otimes \gamma \otimes \gamma') \mapsto s_{n+1} \otimes (1 \otimes \gamma' \otimes \gamma)$$

where $s_{n+1} = (n+1, n+2)$.

The map $T : \mathbb{Q}\mathbb{Q} \rightarrow \mathbb{Q}\mathbb{Q}$ is defined in exactly the same way.

To define $T : \mathbb{Q}\mathbb{P} \rightarrow \mathbb{P}\mathbb{Q}$ we need a map

$$(A_n^\Gamma \otimes \mathbb{k}[\Gamma]) \otimes_{A_n^\Gamma \otimes A_1^\Gamma} A_{n+1}^\Gamma \otimes_{A_n^\Gamma \otimes A_1^\Gamma} (A_n^\Gamma \otimes \mathbb{k}[\Gamma]) \rightarrow A_n^\Gamma \otimes_{A_{n-1}^\Gamma \otimes A_1^\Gamma} (A_{n-1}^\Gamma \otimes \mathbb{k}[\Gamma] \otimes \mathbb{k}[\Gamma]) \otimes_{A_{n-1}^\Gamma \otimes A_1^\Gamma} A_n^\Gamma$$

of (A_n^Γ, A_n^Γ) -bimodules. To define this map it suffices to say where to take $(1 \otimes \gamma) \otimes a \otimes (1 \otimes \gamma')$ where $a \in A_{n+1}^\Gamma$ equals 1 or $s_n = (n, n+1)$. If $a = 1$ then we map it to zero while

$$(1 \otimes \gamma) \otimes s_n \otimes (1 \otimes \gamma') \mapsto 1 \otimes (1 \otimes \gamma' \otimes \gamma) \otimes 1.$$

Finally, to define $T : \mathbb{P}\mathbb{Q} \rightarrow \mathbb{Q}\mathbb{P}$ we need a map

$$A_n^\Gamma \otimes_{A_{n-1}^\Gamma \otimes A_1^\Gamma} (A_{n-1}^\Gamma \otimes \mathbb{k}[\Gamma] \otimes \mathbb{k}[\Gamma]) \otimes_{A_{n-1}^\Gamma \otimes A_1^\Gamma} A_n^\Gamma \rightarrow (A_n^\Gamma \otimes \mathbb{k}[\Gamma]) \otimes_{A_n^\Gamma \otimes A_1^\Gamma} A_{n+1}^\Gamma \otimes_{A_n^\Gamma \otimes A_1^\Gamma} (A_n^\Gamma \otimes \mathbb{k}[\Gamma])$$

of (A_n^Γ, A_n^Γ) -bimodules. This map is uniquely defined by

$$1 \otimes (1 \otimes 1 \otimes 1) \otimes 1 \mapsto (1 \otimes 1) \otimes s_n \otimes (1 \otimes 1).$$

4.3.5. *Definition of adj : QP* → id[-1]{1}. We need a map of (A_n^Γ, A_n^Γ) -bimodules

$$\text{adj} : (n)Q^\Gamma \otimes_{A_{n+1}^\Gamma} P^\Gamma(n) \rightarrow A_n^\Gamma.$$

Now

$$(n)Q^\Gamma \otimes_{A_{n+1}^\Gamma} P^\Gamma(n) = (A_n^\Gamma \otimes \mathbb{k}[\Gamma]) \otimes_{A_n^\Gamma \otimes A_1^\Gamma} A_{n+1}^\Gamma \otimes_{A_n^\Gamma \otimes A_1^\Gamma} (A_n^\Gamma \otimes \mathbb{k}[\Gamma]).$$

Notice that $\mathbb{k}[S_{n+1}]$ as a $\mathbb{k}[S_n]$ -bimodule is free and generated by 1 and $s_n = (n, n+1)$. So the map $\mathbb{k}[S_{n+1}] \rightarrow \mathbb{k}[S_n]$ of $\mathbb{k}[S_n]$ -bimodules given by $1 \mapsto 1$ and $s_n \mapsto 0$ induces a map $A_{n+1}^\Gamma \rightarrow A_n^\Gamma \otimes A_1^\Gamma$ of $A_n^\Gamma \otimes A_1^\Gamma$ -bimodules. Subsequently we obtain a map

$$(15) \quad (n)Q^\Gamma \otimes_{A_{n+1}^\Gamma} P^\Gamma(n) \rightarrow (A_n^\Gamma \otimes \mathbb{k}[\Gamma]) \otimes_{A_n^\Gamma \otimes A_1^\Gamma} (A_n^\Gamma \otimes A_1^\Gamma) \otimes_{A_n^\Gamma \otimes A_1^\Gamma} (A_n^\Gamma \otimes \mathbb{k}[\Gamma])$$

$$(16) \quad \cong (A_n^\Gamma \otimes \mathbb{k}[\Gamma]) \otimes_{A_n^\Gamma \otimes A_1^\Gamma} (A_n^\Gamma \otimes \mathbb{k}[\Gamma]).$$

Using the composition $\mathbb{k}[\Gamma] \otimes_{A_1^\Gamma} \mathbb{k}[\Gamma] \rightarrow \mathbb{k}[\Gamma] \xrightarrow{\text{tr}} \mathbb{k}$ where the first map is multiplication and the second is the trace map (normalized so that $\text{tr}(1) = 1$) we get a morphism

$$(A_n^\Gamma \otimes \mathbb{k}[\Gamma]) \otimes_{A_n^\Gamma \otimes A_1^\Gamma} (A_n^\Gamma \otimes \mathbb{k}[\Gamma]) \rightarrow A_n^\Gamma \otimes_{A_n^\Gamma} A_n^\Gamma = A_n^\Gamma.$$

Composing with (15) defines $\text{adj} : (n)Q^\Gamma \otimes_{A_{n+1}^\Gamma} P^\Gamma(n) \rightarrow A_n^\Gamma$.

4.3.6. *Definition of adj : PQ* → id[1]{-1}. We need a map of $(A_{n+1}^\Gamma, A_{n+1}^\Gamma)$ -bimodules

$$P^\Gamma(n) \otimes_{A_n^\Gamma} (n)Q^\Gamma \rightarrow A_{n+1}^\Gamma[2]\{-2\}.$$

Now

$$P^\Gamma(n) \otimes_{A_n^\Gamma} (n)Q^\Gamma = A_{n+1}^\Gamma \otimes_{A_n^\Gamma \otimes A_1^\Gamma} (A_n^\Gamma \otimes \mathbb{k}[\Gamma] \otimes \mathbb{k}[\Gamma]) \otimes_{A_n^\Gamma \otimes A_1^\Gamma} A_{n+1}^\Gamma$$

so we basically need a map $h : \mathbb{k}[\Gamma] \otimes \mathbb{k}[\Gamma] \rightarrow A_1^\Gamma[2]\{-2\}$ of graded (A_1^Γ, A_1^Γ) -bimodules. Then we define adj as the composition

$$\text{adj} : A_{n+1}^\Gamma \otimes_{A_n^\Gamma \otimes A_1^\Gamma} (A_n^\Gamma \otimes \mathbb{k}[\Gamma] \otimes \mathbb{k}[\Gamma]) \otimes_{A_n^\Gamma \otimes A_1^\Gamma} A_{n+1}^\Gamma \xrightarrow{h} A_{n+1}^\Gamma \otimes_{A_n^\Gamma \otimes A_1^\Gamma} A_{n+1}^\Gamma[2]\{-2\} \rightarrow A_{n+1}^\Gamma[2]\{-2\}$$

where the second map is multiplication.

To define h we use the resolutions (9) and (11) of $\mathbb{k}[\Gamma]$. Tensoring the two resolutions we see that h is defined by a map

$$(A_1^\Gamma \otimes \wedge^2 V^\vee) \otimes A_1^\Gamma \oplus (A_1^\Gamma \otimes V^\vee) \otimes (V^\vee \otimes A_1^\Gamma) \oplus A_1^\Gamma \otimes (\wedge^2 V^\vee \otimes A_1^\Gamma) \rightarrow A_1^\Gamma\{-2\}.$$

We define the map from each summand as

- (1) $((f, \gamma) \otimes (w \wedge w')) \otimes (f', \gamma') \mapsto (f, \gamma)(f', \gamma')\omega(w \wedge w')$
- (2) $((f, \gamma) \otimes w) \otimes (w' \otimes (f', \gamma')) \mapsto (f, \gamma)(f', \gamma')\omega(w \wedge w')$
- (3) $(f, \gamma) \otimes ((w \wedge w') \otimes (f', \gamma')) \mapsto -(f, \gamma)(f', \gamma')\omega(w \wedge w')$

where $\omega : \wedge^2 V^\vee \rightarrow \mathbb{k}$ is our fixed isomorphism.

In order for this map to be well defined (*i.e.* a map of complexes) we need the composition

$$\begin{array}{c} (A_1^\Gamma \otimes \wedge^2 V^\vee) \otimes A_1^\Gamma \oplus (A_1^\Gamma \otimes V^\vee) \otimes (V^\vee \otimes A_1^\Gamma) \oplus A_1^\Gamma \otimes (\wedge^2 V^\vee \otimes A_1^\Gamma) \longrightarrow A_1^\Gamma\{-2\} \\ \uparrow \\ (A_1^\Gamma \otimes \wedge^2 V^\vee) \otimes (V^\vee \otimes A_1^\Gamma) \oplus (A_1^\Gamma \otimes V^\vee) \otimes (\wedge^2 V^\vee \otimes A_1^\Gamma) \end{array}$$

to be zero.

Let us check that the composition $(A_1^\Gamma \otimes \wedge^2 V^\vee) \otimes (V^\vee \otimes A_1^\Gamma) \rightarrow A_1^\Gamma\{-2\}$ is zero. The first map is

$$(f, \gamma) \otimes (w \wedge w') \otimes (w'' \otimes (f', \gamma')) \mapsto ((f, \gamma) \otimes (w \wedge w')) \otimes (f'w'', \gamma') + \\ ((f\gamma \cdot w, \gamma) \otimes w') \otimes (w'' \otimes (f', \gamma')) - \\ ((f\gamma \cdot w', \gamma) \otimes w) \otimes (w'' \otimes (f', \gamma')).$$

Composing with the second map we get

$$(f(\gamma f')(\gamma w''), \gamma \gamma') \omega(w \wedge w') + (f(\gamma f')(\gamma w), \gamma \gamma') \omega(w' \wedge w'') - (f(\gamma f')(\gamma w'), \gamma \gamma') \omega(w \wedge w'').$$

Since the maps are linear in the w 's it suffices to check this is zero when $w = w'$, when $w = w''$ and when $w' = w''$. In all cases one of the three terms is immediately zero and the other two cancel out.

Similarly, the other composition maps $((f, \gamma) \otimes w) \otimes ((w' \wedge w'') \otimes (f', \gamma'))$ to

$$-(f(\gamma w)(\gamma f'), \gamma \gamma') \omega(w' \wedge w'') - (f(\gamma w'')(\gamma f'), \gamma \gamma') \omega(w \wedge w') + (f(\gamma w')(\gamma f'), \gamma \gamma') \omega(w \wedge w'')$$

which also equals zero.

4.3.7. *Definition of $\text{adj} : \text{id} \rightarrow \text{QP}[-1]\{1\}$.* We need a map of (A_n^Γ, A_n^Γ) -bimodules

$$A_n^\Gamma \rightarrow (n)Q^\Gamma \otimes_{A_{n+1}^\Gamma} P^\Gamma(n)[-2]\{2\}$$

which translates to a map

$$(17) \quad A_n^\Gamma[2]\{-2\} \rightarrow (A_n^\Gamma \otimes \mathbb{k}[\Gamma]) \otimes_{A_n^\Gamma \otimes A_1^\Gamma} A_{n+1}^\Gamma \otimes_{A_1^\Gamma \otimes A_n^\Gamma} (\mathbb{k}[\Gamma] \otimes A_n^\Gamma).$$

We first replace each $\mathbb{k}[\Gamma]$ with its resolution using (9) and (11). Then to define the map in (17) we just need to define a map

$$A_n^\Gamma\{-2\} \rightarrow \bigoplus_{k+l=2} (A_n^\Gamma \otimes (\wedge^k V^\vee \otimes A_1^\Gamma)) \otimes_{A_n^\Gamma \otimes A_1^\Gamma} A_{n+1}^\Gamma \otimes_{A_1^\Gamma \otimes A_n^\Gamma} ((A_1^\Gamma \otimes \wedge^l V^\vee) \otimes A_n^\Gamma)$$

of graded (A_n^Γ, A_n^Γ) -bimodules. We send

$$1 \mapsto (1 \otimes 1) \otimes 1 \otimes ((1 \otimes w_1 \wedge w_2) \otimes 1) \\ -(1 \otimes (w_1 \otimes 1)) \otimes 1 \otimes ((1 \otimes w_2) \otimes 1) + (1 \otimes (w_2 \otimes 1)) \otimes 1 \otimes ((1 \otimes w_1) \otimes 1) \\ -(1 \otimes (w_1 \wedge w_2 \otimes 1)) \otimes 1 \otimes (1 \otimes 1)$$

where w_1, w_2 is our chosen basis of V^\vee . This uniquely determines the map.

To see this is well defined (*i.e.* a map of complexes) we need to check that the composition

$$\bigoplus_{k+l=1} (A_n^\Gamma \otimes (\wedge^k V^\vee \otimes A_1^\Gamma)) \otimes_{A_n^\Gamma \otimes A_1^\Gamma} A_{n+1}^\Gamma \otimes_{A_1^\Gamma \otimes A_n^\Gamma} ((A_1^\Gamma \otimes \wedge^l V^\vee) \otimes A_n^\Gamma) \\ \uparrow \\ A_n^\Gamma\{-2\} \longrightarrow \bigoplus_{k+l=2} (A_n^\Gamma \otimes (\wedge^k V^\vee \otimes A_1^\Gamma)) \otimes_{A_n^\Gamma \otimes A_1^\Gamma} A_{n+1}^\Gamma \otimes_{A_1^\Gamma \otimes A_n^\Gamma} ((A_1^\Gamma \otimes \wedge^l V^\vee) \otimes A_n^\Gamma)$$

is zero. The check of this fact is a straight-forward exercise.

4.3.8. *Definition of $\text{adj} : \text{id} \rightarrow \text{PQ}[1]\{-1\}$.* We need a map of graded $(A_{n+1}^\Gamma, A_{n+1}^\Gamma)$ -bimodules $A_{n+1}^\Gamma \rightarrow P^\Gamma(n) \otimes_{A_n^\Gamma} (n)Q^\Gamma$ or equivalently a map

$$A_{n+1}^\Gamma \rightarrow A_{n+1}^\Gamma \otimes_{A_n^\Gamma \otimes A_1^\Gamma} (A_n^\Gamma \otimes \mathbb{k}[\Gamma] \otimes \mathbb{k}[\Gamma]) \otimes_{A_n^\Gamma \otimes A_1^\Gamma} A_{n+1}^\Gamma.$$

We send

$$(18) \quad 1 \mapsto \sum_{i=0}^n \sum_{\gamma \in \Gamma} s_i \dots s_n \otimes (1 \otimes \gamma \otimes \gamma^{-1}) \otimes s_n \dots s_i$$

where $s_i = (i, i+1) \in S_{n+1}$. Here $s_i \dots s_n = 1$ if $i = 0$ by convention.

To check this bimodule map is well defined we need to show that

$$\sum_{i=0}^n \sum_{\gamma \in \Gamma} a s_i \dots s_n \otimes (1 \otimes \gamma \otimes \gamma^{-1}) \otimes s_n \dots s_i = \sum_{i=0}^n \sum_{\gamma \in \Gamma} s_i \dots s_n \otimes (1 \otimes \gamma \otimes \gamma^{-1}) \otimes s_n \dots s_i a$$

for any $a \in A_{n+1}^\Gamma$. If $a \in (A_1^\Gamma)^{\otimes n+1} \subset A_{n+1}^\Gamma$ then

$$\begin{aligned} \sum_{i=0}^n \sum_{\gamma \in \Gamma} a s_i \dots s_n \otimes (1 \otimes \gamma \otimes \gamma^{-1}) \otimes s_n \dots s_i &= \sum_{i=0}^n \sum_{\gamma \in \Gamma} s_i \dots s_n b_i \otimes (1 \otimes \gamma \otimes \gamma^{-1}) \otimes s_n \dots s_i \\ &= \sum_{i=0}^n \sum_{\gamma \in \Gamma} s_i \dots s_n \otimes (1 \otimes \gamma \otimes \gamma^{-1}) \otimes b_i s_n \dots s_i \\ &= \sum_{i=0}^n \sum_{\gamma \in \Gamma} s_i \dots s_n \otimes (1 \otimes \gamma \otimes \gamma^{-1}) \otimes s_n \dots s_i a \end{aligned}$$

where $b_i = (s_n \dots s_i) \cdot a$. The second equality follows since $\sum_{\gamma \in \Gamma} \gamma \otimes \gamma^{-1}$ lies in the centre of $\mathbb{k}[\Gamma] \otimes_{\mathbb{k}} \mathbb{k}[\Gamma]$.

Since A_{n+1}^Γ is generated by $\mathbb{k}[S_{n+1}]$ as an $((A_1^\Gamma)^{\otimes n+1}, (A_1^\Gamma)^{\otimes n+1})$ -bimodule it remains to show that

$$\sum_{i=0}^n \sum_{\gamma \in \Gamma} s_k s_i \dots s_n \otimes (1 \otimes \gamma \otimes \gamma^{-1}) \otimes s_n \dots s_i = \sum_{i=0}^n \sum_{\gamma \in \Gamma} s_i \dots s_n \otimes (1 \otimes \gamma \otimes \gamma^{-1}) \otimes s_n \dots s_i s_k$$

for $k = 1, \dots, n$. The left hand side is the sum over $\gamma \in \Gamma$ of

$$\begin{aligned} &\sum_{i=0}^{k-1} s_i \dots s_n s_{k-1} \otimes (1 \otimes \gamma \otimes \gamma^{-1}) \otimes s_n \dots s_i + s_k s_{k+1} \dots s_n \otimes (1 \otimes \gamma \otimes \gamma^{-1}) \otimes s_n \dots s_{k+1} \\ &+ s_{k+1} \dots s_n \otimes (1 \otimes \gamma \otimes \gamma^{-1}) \otimes s_n \dots s_k + \sum_{i=k+2}^n s_i \dots s_n s_k \otimes (1 \otimes \gamma \otimes \gamma^{-1}) \otimes s_n \dots s_i \end{aligned}$$

because $s_k s_i \dots s_n = s_i \dots s_n s_{k-1}$ if $i \leq k-1$ and $s_k s_i \dots s_n = s_i \dots s_n s_k$ if $i \geq k+2$. A similar calculation of the right side yields the same expression so adj is well defined.

4.4. Main Theorem #2. The second main theorem of this paper is the following:

Theorem 2. *The natural transformations X , T and adj satisfy the Heisenberg 2-relations and give a categorical Heisenberg action of \mathcal{H}_Γ on $\oplus_{n \geq 0} D(A_n^\Gamma\text{-gmod})$.*

We shall check all the Heisenberg relations required for the proof of Theorem 2 in the next section.

Remark 4.1. In type A (when Γ is a cyclic group) one can define everything \mathbb{k}^\times -equivariantly where the $\mathbb{k}^\times \subset SL(V)$ is the torus which commutes with Γ . More precisely, the action of \mathbb{k}^\times on V induces an action on $\text{Sym}^*(V^\vee)$ and instead of A_n^Γ one uses

$$\hat{A}_n^\Gamma := [(\text{Sym}^*(V^\vee) \rtimes (\Gamma \times \mathbb{k}^\times)) \otimes (\text{Sym}^*(V^\vee) \rtimes (\Gamma \times \mathbb{k}^\times)) \otimes \dots \otimes (\text{Sym}^*(V^\vee) \rtimes (\Gamma \times \mathbb{k}^\times))] \rtimes S_n.$$

It is easy to check that all the 1-morphisms and 2-morphisms defined above are compatible with this extra \mathbb{k}^\times -structure. This means Theorem 2 still holds so we get an action of \mathcal{H}_Γ on $\oplus_{n \geq 0} D(\hat{A}_n^\Gamma\text{-gmod})$ (see also [FJW2]).

5. PROOF OF THEOREM 2

5.1. Composition of X 's. We can define $X(b) : \mathbb{P} \rightarrow \mathbb{P}[[b]]\{-|b|\}$ for any homogeneous $b \in B^\Gamma$ by composing a sequence of $X(\gamma)$ and $X(v)$ where $\gamma \in \Gamma$ and $v \in V$. In order for this to be well defined we need to check that

- (1) $X(\gamma)X(\gamma') = X(\gamma\gamma')$ for any $\gamma, \gamma' \in \Gamma$
- (2) $X(\gamma)X(v) = X(\gamma \cdot v)X(\gamma)$ for any $\gamma \in \Gamma$ and $v \in V$
- (3) $X(v')X(v) = -X(v)X(v')$.

(1) The first assertion is clear since Γ acts on $P^\Gamma(n) = A_{n+1} \otimes_{A_n \otimes A_1} (A_n \otimes \mathbb{k}[\Gamma])$ by right multiplication on $\mathbb{k}[\Gamma]$.

(2) To see the second assertion we replace $\mathbb{k}[\Gamma]$ by its free resolution (9). In the free resolution Γ acts on the right only on the first factor of $A_1^\Gamma \otimes \wedge^i V^\vee$. Writing out the composition we see that two pairs of compositions should agree:

- $A_1^\Gamma \otimes V^\vee \xrightarrow{\gamma} A_1^\Gamma \otimes V^\vee \xrightarrow{\phi_v} A_1^\Gamma\{-1\}$ and
 $A_1^\Gamma \otimes V^\vee \xrightarrow{\phi_{\gamma v}} A_1^\Gamma\{-1\} \xrightarrow{\gamma} A_1^\Gamma\{-1\}$
- $A_1^\Gamma \otimes \wedge^2 V^\vee \xrightarrow{\gamma} A_1^\Gamma \otimes \wedge^2 V^\vee \xrightarrow{\phi'_v} A_1^\Gamma \otimes V^\vee\{-1\}$ and
 $A_1^\Gamma \otimes \wedge^2 V^\vee \xrightarrow{\phi'_{\gamma v}} A_1^\Gamma \otimes V^\vee\{-1\} \xrightarrow{\gamma} A_1^\Gamma \otimes V^\vee\{-1\}$.

In the first pair the first composition is equal to

$$(f, \gamma') \otimes w \mapsto (f, \gamma'\gamma) \otimes (\gamma^{-1}w) \mapsto \langle \gamma^{-1}w, v \rangle (f, \gamma'\gamma)$$

while the second composition is equal to

$$(f, \gamma') \otimes w \mapsto \langle w, \gamma v \rangle (f, \gamma') \mapsto \langle w, \gamma v \rangle (f, \gamma'\gamma)$$

and these are the same since $\langle \cdot, \cdot \rangle$ is invariant under the action of Γ .

Similarly, in the second pair the first composition is equal to

$$\begin{aligned} (f, \gamma') \otimes (w_1 \wedge w_2) &\mapsto (f, \gamma'\gamma) \otimes (\gamma^{-1}w_1 \wedge \gamma^{-1}w_2) \\ &\mapsto -\langle \gamma^{-1}w_2, v \rangle (f, \gamma'\gamma) \otimes (\gamma^{-1}w_1) + \langle \gamma^{-1}w_1, v \rangle (f, \gamma'\gamma) \otimes (\gamma^{-1}w_2) \end{aligned}$$

while the second composition is

$$\begin{aligned} (f, \gamma') \otimes (w_1 \wedge w_2) &\mapsto -\langle w_2, \gamma v \rangle (f, \gamma') \otimes w_1 + \langle w_1, \gamma v \rangle (f, \gamma') \otimes w_2 \\ &\mapsto -\langle w_2, \gamma v \rangle (f, \gamma'\gamma) \otimes (\gamma^{-1}w_1) + \langle w_1, \gamma v \rangle (f, \gamma'\gamma) \otimes (\gamma^{-1}w_2) \end{aligned}$$

which is clearly the same as the first composition.

(3) To see the third assertion we again replace $\mathbb{k}[\Gamma]$ by its free resolution (9) and then we need to show that the compositions

$$A_1^\Gamma \otimes \wedge^2 V^\vee \xrightarrow{\phi'_{v'}} A_1^\Gamma \otimes V^\vee\{-1\} \xrightarrow{\phi_v} A_1^\Gamma\{-2\} \text{ and } A_1^\Gamma \otimes \wedge^2 V^\vee \xrightarrow{\phi'_v} A_1^\Gamma \otimes V^\vee\{-1\} \xrightarrow{\phi_{v'}} A_1^\Gamma\{-2\}$$

differ precisely by a minus sign. The first composition is

$$\begin{aligned} (f, \gamma) \otimes (w_1 \wedge w_2) &\mapsto -\langle w_2, v' \rangle (f, \gamma) \otimes w_1 + \langle w_1, v' \rangle (f, \gamma) \otimes w_2 \\ &\mapsto -\langle w_1, v \rangle \langle w_2, v' \rangle (f, \gamma) + \langle w_2, v \rangle \langle w_1, v' \rangle (f, \gamma) \end{aligned}$$

and similarly the second composition is

$$(f, \gamma) \otimes (w_1 \wedge w_2) \mapsto -\langle w_1, v' \rangle \langle w_2, v \rangle (f, \gamma) + \langle w_2, v' \rangle \langle w_1, v \rangle (f, \gamma).$$

These two compositions clearly differ by multiplication by -1 .

This shows that $B^\Gamma = \Lambda^*(V) \rtimes \Gamma$ acts on \mathbb{P} and a similar proof shows that it also acts on \mathbb{Q} .

5.1.1. *X's on different strands.* We also need to check that elements of B^Γ on different strands supercommute, namely

$$(IX(b))(X(b')I) = (-1)^{|b||b'|}(X(b')I)(IX(b)) \text{ for any homogeneous } b, b' \in B^\Gamma.$$

This follows from the discussion at the beginning of this section. $X(b)$ is a map of degree $|b|$ of complexes and that such maps supercommute. In other words, we are using that whenever $f : A_\bullet \rightarrow A_{\bullet+|f|}$ and $g : A'_\bullet \rightarrow A'_{\bullet+|g|}$ are maps of complexes then $(f \otimes 1)(1 \otimes g) = (-1)^{|f||g|}(1 \otimes g)(f \otimes 1)$ as maps of complexes $A_\bullet \otimes B_\bullet \rightarrow A_{\bullet+|f|} \otimes B_{\bullet+|g|}$.

5.2. **Adjoint relations.** We now check that the following compositions involving adjunctions are all equal to the identity:

$$\begin{aligned} (1) \quad & \mathbb{P} \xrightarrow{I\text{adj}} \mathbb{P}\mathbb{Q}\mathbb{P}[-1]\{1\} \xrightarrow{\text{adj}I} \mathbb{P} \text{ and } \mathbb{Q} \xrightarrow{\text{adj}I} \mathbb{Q}\mathbb{P}\mathbb{Q}[-1]\{1\} \xrightarrow{I\text{adj}} \mathbb{Q} \\ (2) \quad & \mathbb{P} \xrightarrow{\text{adj}I} \mathbb{P}\mathbb{Q}\mathbb{P}[1]\{-1\} \xrightarrow{I\text{adj}} \mathbb{P} \text{ and } \mathbb{Q} \xrightarrow{I\text{adj}} \mathbb{Q}\mathbb{P}\mathbb{Q}[1]\{-1\} \xrightarrow{\text{adj}I} \mathbb{Q}. \end{aligned}$$

This will prove the graphical relations

The diagram shows three graphical representations of the identity. On the left, a strand starts from the bottom, forms a cup shape, and then continues upwards. This is equal to a single vertical strand. This is also equal to a strand that starts from the top, forms a cap shape, and then continues downwards.

in both possible orientations.

5.2.1. *The composition $\mathbb{P} \xrightarrow{I\text{adj}} \mathbb{P}\mathbb{Q}\mathbb{P}[-1]\{1\} \xrightarrow{\text{adj}I} \mathbb{P}$.* To show this is the identity it suffices to check that the composition $C_i \rightarrow D_i\{2\} \rightarrow C_i$ is the identity for $i = 0, 1, 2$ where

$$C_i := A_{n+1}^\Gamma \otimes_{A_n^\Gamma \otimes A_1^\Gamma} (A_n^\Gamma \otimes (A_1^\Gamma \otimes \wedge^i V^\vee))$$

$$\begin{aligned} D_i := & A_{n+1}^\Gamma \otimes_{A_n^\Gamma \otimes A_1^\Gamma} (A_n^\Gamma \otimes (A_1^\Gamma \otimes \wedge^i V^\vee)) \otimes_{A_n^\Gamma} \\ & \bigoplus_{k+l=2} (A_n^\Gamma \otimes (\wedge^k V^\vee \otimes A_1^\Gamma)) \otimes_{A_n^\Gamma \otimes A_1^\Gamma} A_{n+1}^\Gamma \otimes_{A_1^\Gamma \otimes A_n^\Gamma} ((A_1^\Gamma \otimes \wedge^l V^\vee) \otimes A_n^\Gamma). \end{aligned}$$

We will prove the case $n = 0$ which is the same as the general case but simplifies the notation. In this case the composition is

$$(A_1^\Gamma \otimes \wedge^i V^\vee) \xrightarrow{f} (A_1^\Gamma \otimes \wedge^i V^\vee) \otimes_{A_0^\Gamma} \left(\bigoplus_{k+l=2} (\wedge^k V^\vee \otimes A_1^\Gamma) \otimes_{A_1^\Gamma} (A_1^\Gamma \otimes \wedge^l V^\vee) \right) \{2\} \xrightarrow{g} (A_1^\Gamma \otimes \wedge^i V^\vee).$$

The image of any element under f consists of three terms. The only term that will be non-zero after applying g will be the term

$$(A_1^\Gamma \otimes \wedge^i V^\vee) \otimes_{A_0^\Gamma} (\wedge^{2-i} V^\vee \otimes A_1^\Gamma) \otimes_{A_1^\Gamma} (A_1^\Gamma \otimes \wedge^i V^\vee).$$

If $i = 0$ and $a \in A_1^\Gamma$ then

$$a \mapsto -a \otimes ((w_1 \wedge w_2 \otimes 1) \otimes 1) \mapsto (a \otimes 1) \cdot \omega(w_1 \wedge w_2) = a$$

which proves that the composition is the identity when $i = 0$.

If $i = 1$ then

$$\begin{aligned} (f, \gamma) \otimes w & \mapsto ((f, \gamma) \otimes w) \otimes (-(w_1 \otimes 1) \otimes (1 \otimes w_2) + (w_2 \otimes 1) \otimes (1 \otimes w_1)) \\ & \mapsto -((f, \gamma) \otimes w_2) \omega(w \wedge w_1) + ((f, \gamma) \otimes w_1) \omega(w \wedge w_2) \end{aligned}$$

where $a = (f, \gamma)$. Since all maps are linear in the w 's it suffices to check the two cases $w = w_1$ and $w = w_2$. In the first case the first term is zero and we get

$$(f, \gamma) \otimes w_1 \mapsto ((f, \gamma) \otimes w_1) \omega(w_1 \wedge w_2) = (f, \gamma) \otimes w_1$$

while in the second case

$$(f, \gamma) \otimes w_2 \mapsto -((f, \gamma) \otimes w_2) \otimes \omega(w_2 \wedge w_1) = (f, \gamma) \otimes w_2.$$

If $i = 2$ and $a \in A_1^\Gamma$ then

$$a \otimes (w \wedge w') \mapsto (a \otimes (w \wedge w')) \otimes 1 \otimes (1 \otimes (w_1 \wedge w_2)) \mapsto a \otimes (w_1 \wedge w_2) \omega(w \wedge w')$$

and it is easy to check this equals $a \otimes (w \wedge w')$ so that the composition is the identity.

This concludes the proof of the first relation in (1). The fact that the composition $\mathbb{Q} \xrightarrow{\text{adj}I} \text{QPQ}[-1]\{1\} \xrightarrow{I\text{adj}} \mathbb{Q}$ is also the identity follows similarly.

5.2.2. *The composition* $\mathbb{P} \xrightarrow{\text{adj}I} \text{PQP}[1]\{-1\} \xrightarrow{I\text{adj}} \mathbb{P}$. This is the same as the composition

$$\begin{aligned} A_{n+1}^\Gamma \otimes_{A_n^\Gamma \otimes A_1^\Gamma} (A_n^\Gamma \otimes \mathbb{k}[\Gamma]) &\longrightarrow A_{n+1}^\Gamma \otimes_{A_n^\Gamma \otimes A_1^\Gamma} (A_n^\Gamma \otimes \mathbb{k}[\Gamma] \otimes \mathbb{k}[\Gamma]) \otimes_{A_n^\Gamma \otimes A_1^\Gamma} A_{n+1}^\Gamma \otimes_{A_n^\Gamma \otimes A_1^\Gamma} (A_n^\Gamma \otimes \mathbb{k}[\Gamma]) \\ &\qquad\qquad\qquad \downarrow \\ &A_{n+1}^\Gamma \otimes_{A_n^\Gamma \otimes A_1^\Gamma} (A_n^\Gamma \otimes \mathbb{k}[\Gamma]). \end{aligned}$$

Using (18) the first map is given by

$$1 \otimes (1 \otimes 1) \mapsto \sum_{i=0}^n \sum_{\gamma \in \Gamma} s_i \dots s_n \otimes (1 \otimes \gamma \otimes \gamma^{-1}) \otimes s_n \dots s_i \otimes (1 \otimes 1).$$

Composing with the second map all terms are zero unless $i = 0$ (recall that $s_i \dots s_n = 1$ if $i = 0$) in which case we get the composition

$$\begin{aligned} 1 \otimes (1 \otimes 1) &\mapsto \sum_{\gamma \in \Gamma} 1 \otimes (1 \otimes \gamma \otimes \gamma^{-1}) \otimes 1 \otimes (1 \otimes 1) \\ &\mapsto \sum_{\gamma \in \Gamma} 1 \otimes_{A_n^\Gamma \otimes A_1^\Gamma} (1 \otimes \gamma) \otimes_{A_n^\Gamma} (\text{tr}(\gamma^{-1})) \\ &= 1 \otimes_{A_n^\Gamma \otimes A_1^\Gamma} (1 \otimes 1) \otimes_{A_n^\Gamma} \text{tr}(1) \\ &= 1 \otimes (1 \otimes 1) \end{aligned}$$

where to get the last two equalities we use that $\text{tr}(\gamma^{-1}) = 0$ unless $\gamma = 1$ in which case $\text{tr}(1) = 1$. This proves that the composition $\mathbb{P} \xrightarrow{\text{adj}I} \text{PQP}[1] \xrightarrow{I\text{adj}} \mathbb{P}$ is the identity. The fact that $\mathbb{Q} \xrightarrow{I\text{adj}} \text{QPQ}[1] \xrightarrow{\text{adj}I} \mathbb{Q}$ is the identity follows similarly.

5.3. Dots and adjunctions. Next we study how natural transformations of \mathbb{P} and \mathbb{Q} interact with the adjunctions. We will show that the following pairs of maps are equal for any $b \in B^\Gamma$ (for simplicity we omit shifts in this section)

- (1) $\text{QP} \xrightarrow{IX(b)} \text{QP} \xrightarrow{\text{adj}} \text{id}$ and $\text{QP} \xrightarrow{X(b)I} \text{QP} \xrightarrow{\text{adj}} \text{id}$
- (2) $\text{PQ} \xrightarrow{X(b)I} \text{PQ} \xrightarrow{\text{adj}} \text{id}$ and $\text{PQ} \xrightarrow{IX(b)} \text{PQ} \xrightarrow{\text{adj}} \text{id}$
- (3) $\text{id} \xrightarrow{\text{adj}} \text{PQ} \xrightarrow{X(b)I} \text{PQ}$ and $\text{id} \xrightarrow{\text{adj}} \text{PQ} \xrightarrow{IX(b)} \text{PQ}$
- (4) $\text{id} \xrightarrow{\text{adj}} \text{QP} \xrightarrow{IX(b)} \text{QP}$ and $\text{id} \xrightarrow{\text{adj}} \text{QP} \xrightarrow{X(b)I} \text{QP}$.

Although these two compositions are not equal as maps of complexes, they are homotopic to each other. To see this we need to define a map h_v of (A_n^Γ, A_n^Γ) bimodules such that the following diagram commutes

$$(22) \quad \begin{array}{ccc} (A_n^\Gamma \otimes A_1^\Gamma) \otimes_{A_n^\Gamma \otimes A_1^\Gamma} A_{n+1}^\Gamma \otimes_{A_n^\Gamma \otimes A_1^\Gamma} (A_n^\Gamma \otimes A_1^\Gamma) & & \\ \uparrow & \dashrightarrow^{h_v} & \\ C_1 & \xrightarrow{\text{adj} \circ (I\phi_v \oplus 0) - \text{adj} \circ (0 \oplus \psi_v I)} & A_n^\Gamma. \end{array}$$

The map h_v is determined by where it takes elements of the form

$$(1 \otimes a) \otimes a' \otimes (1 \otimes a'')$$

where $a, a'' \in A_1^\Gamma$ and either $a' = 1$ or $a' = (n, n+1)$. If $a' = (n, n+1)$ then h_v sends $(1 \otimes a) \otimes a' \otimes (1 \otimes a'')$ to zero. If $a' = 1$ then h_v maps it to $\langle aa'', v \rangle 1$, where $\langle aa'', v \rangle$ is zero unless aa'' is of degree one, in which case $\langle aa'', v \rangle = \langle w, v \rangle \text{tr}(\gamma)$ for $aa'' = (w, \gamma) \in A_1^\Gamma$.

We now show that the diagram (22) commutes. Consider first the term where $k = 0$ in C_1 . We see that

$$C_1 \ni (1 \otimes \gamma) \otimes 1 \otimes (1 \otimes (\gamma'' \otimes w)) \mapsto (1 \otimes \gamma) \otimes 1 \otimes (1 \otimes (\gamma'' w, \gamma'')) \xrightarrow{h_v} 1 \langle \gamma \gamma'' w, v \rangle \text{tr}(\gamma \gamma'').$$

This composition is zero if $\gamma \gamma'' \neq 1$ and equal to $1 \langle w, v \rangle \text{tr}(1)$ otherwise.

Now $\text{adj} \circ (0 \oplus \psi_v I)$ kills this term so, using (20), we see this is the same as

$$(\text{adj} \circ (I\phi_v \oplus 0) - \text{adj} \circ (0 \oplus \psi_v I)) ((1 \otimes \gamma) \otimes 1 \otimes (1 \otimes (\gamma'' \otimes w))).$$

So diagram (22) commutes when $k = 0$.

For the $k = 1$ term in C_1 we have

$$C_1 \ni (1 \otimes (w \otimes \gamma)) \otimes 1 \otimes (1 \otimes \gamma'') \mapsto (1 \otimes (w, \gamma)) \otimes 1 \otimes (1 \otimes \gamma'') \xrightarrow{h_v} 1 \langle w, v \rangle \text{tr}(\gamma \gamma'').$$

Also, $\text{adj} \circ (I\phi_v \oplus 0)$ acts by zero so using (21) we see that

$$(\text{adj} \circ (I\phi_v \oplus 0) - \text{adj} \circ (0 \oplus \psi_v I)) (1 \otimes (w \otimes \gamma)) \otimes 1 \otimes (1 \otimes \gamma'') = 1 \langle w, v \rangle \text{tr}(\gamma \gamma'').$$

So diagram (22) also commutes when $k = 1$.

5.3.3. *Relation (2) when $b = v$.* After resolving both copies of $\mathbb{k}[\Gamma]$ in

$$P^\Gamma(n) \otimes_{A_n^\Gamma} (n) Q^\Gamma = A_{n+1}^\Gamma \otimes_{A_n^\Gamma \otimes A_1^\Gamma} (A_n^\Gamma \otimes \mathbb{k}[\Gamma] \otimes \mathbb{k}[\Gamma]) \otimes_{A_n^\Gamma \otimes A_1^\Gamma} A_{n+1}^\Gamma$$

the composition $PQ \xrightarrow{X(v)I} PQ \xrightarrow{\text{adj}} \text{id}$ is induced by the map

$$\oplus_{k+l=3} (A_1^\Gamma \otimes \wedge^k V^\vee) \otimes (\wedge^l V^\vee \otimes A_1^\Gamma) \xrightarrow{\phi_v I \oplus \phi'_v I} \oplus_{k+l=2} (A_1^\Gamma \otimes \wedge^k V^\vee) \otimes (\wedge^l V^\vee \otimes A_1^\Gamma) \rightarrow A_1^\Gamma$$

given by

$$\begin{aligned} (1 \otimes (w \wedge w')) \otimes (w'' \otimes 1) &\mapsto (-\langle w', v \rangle 1 \otimes w) + \langle w, v \rangle 1 \otimes w' \otimes (w'' \otimes 1) \\ &\mapsto 1(-\langle w', v \rangle \omega(w \wedge w'') + \langle w, v \rangle \omega(w' \wedge w'')) \end{aligned}$$

on one summand and similarly

$$\begin{aligned} (1 \otimes w) \otimes ((w' \wedge w'') \otimes 1) &\mapsto 1 \langle w, v \rangle \otimes ((w' \wedge w'') \otimes 1) \\ &\mapsto -1 \langle w, v \rangle \omega(w' \wedge w'') \end{aligned}$$

on the second summand.

On the other hand, the composition $PQ \xrightarrow{IX(v)} PQ \xrightarrow{\text{adj}} \text{id}$ is given by

$$\begin{aligned} (1 \otimes (w \wedge w')) \otimes (w'' \otimes 1) &\mapsto (1 \otimes (w \wedge w')) \otimes -\langle v, w'' \rangle 1 \\ &\mapsto -1 \langle v, w'' \rangle \omega(w \wedge w') \end{aligned}$$

on one summand and similarly

$$\begin{aligned} (1 \otimes w) \otimes ((w' \wedge w'') \otimes 1) &\mapsto (1 \otimes w) \otimes (-\langle v, w' \rangle w'' \otimes 1 + \langle v, w'' \rangle w' \otimes 1) \\ &\mapsto 1 (-\langle v, w' \rangle \omega(w \wedge w'') + \langle v, w'' \rangle \omega(w \wedge w')) \end{aligned}$$

on the other summand. It is now easy to check that these maps are equal (by the linearity in w it suffices to check the three cases $w = w'$, $w = w''$ and $w' = w''$).

5.4. Pitchfork relations. Next we check that the following compositions are equal:

- (1) $P \xrightarrow{I\text{adj}} PPQ[1]\{-1\} \xrightarrow{TI} PPQ[1]\{-1\}$ and $P \xrightarrow{\text{adj}I} PQP[1]\{-1\} \xrightarrow{IT} PPQ[1]\{-1\}$
- (2) $Q \xrightarrow{I\text{adj}} QPQ[1]\{-1\} \xrightarrow{TI} PQQ[1]\{-1\}$ and $Q \xrightarrow{\text{adj}I} PQQ[1]\{-1\} \xrightarrow{IT} PQQ[1]\{-1\}$
- (3) $PPQ \xrightarrow{IT} PQP \xrightarrow{\text{adj}I} P[1]\{-1\}$ and $PPQ \xrightarrow{TI} PPQ \xrightarrow{I\text{adj}} P[1]\{-1\}$
- (4) $PQQ \xrightarrow{IT} PQQ \xrightarrow{\text{adj}I} Q[1]\{-1\}$ and $PQQ \xrightarrow{TI} PQQ \xrightarrow{I\text{adj}} Q[1]\{-1\}$

This will check the following defining isotopy relations for 2-morphisms in \mathcal{H}'_Γ :

Notice that one also has four more relations where one reverses the orientation of the cups or cups, but these all follow formally from the relations above and the adjointness relations from section 5.2. These pitchfork relations, together with the adjunction relations which allow the straightening of an S-shape, imply that any two diagrams without dots differing by a rel boundary planar isotopy define the same 2-morphism.

5.4.1. Pitchfork relations (1). The first composition is a map

$$A_{n+1}^\Gamma \otimes_{A_n^\Gamma \otimes A_1^\Gamma} (A_n^\Gamma \otimes \mathbb{k}[\Gamma]) \xrightarrow{I\text{adj}} C \xrightarrow{TI} C$$

where

$$C := A_{n+1}^\Gamma \otimes_{A_n^\Gamma \otimes A_1^\Gamma} (A_n^\Gamma \otimes \mathbb{k}[\Gamma]) \otimes_{A_n^\Gamma} A_n^\Gamma \otimes_{A_{n-1}^\Gamma \otimes A_1^\Gamma} (A_{n-1}^\Gamma \otimes \mathbb{k}[\Gamma] \otimes \mathbb{k}[\Gamma]) \otimes_{A_{n-1}^\Gamma \otimes A_1^\Gamma} A_n^\Gamma.$$

This composition is determined by

$$\begin{aligned} 1 \otimes (1 \otimes 1) &\mapsto \sum_{i=0}^{n-1} \sum_{\gamma \in \Gamma} 1 \otimes (1 \otimes 1) \otimes (s_i \dots s_{n-1}) \otimes (1 \otimes \gamma \otimes \gamma^{-1}) \otimes (s_{n-1} \dots s_i) \\ &= \sum_{i=0}^{n-1} \sum_{\gamma \in \Gamma} (s_i \dots s_{n-1}) \otimes (1 \otimes 1) \otimes 1 \otimes (1 \otimes \gamma \otimes \gamma^{-1}) \otimes (s_{n-1} \dots s_i) \\ &\mapsto \sum_{i=0}^{n-1} \sum_{\gamma \in \Gamma} (s_i \dots s_{n-1} s_n) \otimes (1 \otimes \gamma) \otimes 1 \otimes (1 \otimes 1 \otimes \gamma^{-1}) \otimes (s_{n-1} \dots s_i). \end{aligned}$$

On the other hand, the second composition in (1) is a map

$$A_{n+1}^\Gamma \otimes_{A_n^\Gamma \otimes A_1^\Gamma} (A_n^\Gamma \otimes \mathbb{k}[\Gamma]) \xrightarrow{\text{adj}^I} C_1 \xrightarrow{IT} C_2$$

where

$$\begin{aligned} C_1 &:= A_{n+1}^\Gamma \otimes_{A_n^\Gamma \otimes A_1^\Gamma} (A_n^\Gamma \otimes \mathbb{k}[\Gamma] \otimes \mathbb{k}[\Gamma]) \otimes_{A_n^\Gamma \otimes A_1^\Gamma} A_{n+1}^\Gamma \otimes_{A_n^\Gamma \otimes A_1^\Gamma} (A_n^\Gamma \otimes \mathbb{k}[\Gamma]) \\ C_2 &:= A_{n+1}^\Gamma \otimes_{A_n^\Gamma \otimes A_1^\Gamma} (A_n^\Gamma \otimes \mathbb{k}[\Gamma]) \otimes_{A_n^\Gamma} A_n^\Gamma \otimes_{A_{n-1}^\Gamma \otimes A_1^\Gamma} (A_{n-1}^\Gamma \otimes \mathbb{k}[\Gamma] \otimes \mathbb{k}[\Gamma]) \otimes_{A_{n-1}^\Gamma \otimes A_1^\Gamma} A_n^\Gamma. \end{aligned}$$

It is determined by

$$\begin{aligned} 1 \otimes (1 \otimes 1) &\mapsto \sum_{i=0}^n \sum_{\gamma \in \Gamma} (s_i \dots s_n) \otimes (1 \otimes \gamma \otimes \gamma^{-1}) \otimes (s_n \dots s_i) \otimes (1 \otimes 1) \\ &= \sum_{i=1}^n \sum_{\gamma \in \Gamma} (s_i \dots s_n) \otimes (1 \otimes \gamma \otimes \gamma^{-1}) \otimes s_n \otimes (s_{n-1} \dots s_i \otimes 1) \\ &\quad + \sum_{\gamma \in \Gamma} 1 \otimes (1 \otimes \gamma \otimes \gamma^{-1}) \otimes 1 \otimes (1 \otimes 1) \\ &\mapsto \sum_{i=1}^n \sum_{\gamma \in \Gamma} (s_i \dots s_n) \otimes (1 \otimes \gamma) \otimes 1 \otimes (1 \otimes 1 \otimes \gamma^{-1}) \otimes (s_{n-1} \dots s_i). \end{aligned}$$

The two compositions are equal, thus we see that both sides of the first pitchfork relation are equal.

The proof of relation (2) is very similar to the proof of relation (1), and we omit the details.

5.4.2. *Pitchfork relation (3)*. Resolving every copy of $\mathbb{k}[\Gamma]$ the first composition in (3) is

$$C_1[-1]\{1\} \xrightarrow{IT} C_2[-1]\{1\} \xrightarrow{\text{adj}^I} \bigoplus_l A_{n+1}^\Gamma \otimes_{A_n^\Gamma \otimes A_1^\Gamma} (A_n^\Gamma \otimes (A_1^\Gamma \otimes \wedge^l V^\vee))[1]\{-1\}$$

where

$$\begin{aligned} C_1 &:= \bigoplus_{k,l,m} A_{n+1}^\Gamma \otimes_{A_n^\Gamma \otimes A_1^\Gamma} (A_n^\Gamma \otimes (A_1^\Gamma \otimes \wedge^k V^\vee)) \otimes_{A_n^\Gamma} A_n^\Gamma \otimes_{A_{n-1}^\Gamma \otimes A_1^\Gamma} (A_{n-1}^\Gamma \otimes (A_1^\Gamma \otimes \wedge^l V^\vee)) \\ &\quad \otimes_{A_{n-1}^\Gamma} (A_{n-1}^\Gamma \otimes (A_1^\Gamma \otimes \wedge^m V^\vee)) \otimes_{A_{n-1}^\Gamma \otimes A_1^\Gamma} A_n^\Gamma \\ C_2 &:= \bigoplus_{k,l,m} A_{n+1}^\Gamma \otimes_{A_n^\Gamma \otimes A_1^\Gamma} (A_n^\Gamma \otimes (A_1^\Gamma \otimes \wedge^k V^\vee)) \\ &\quad \otimes_{A_n^\Gamma} (A_n^\Gamma \otimes (\wedge^m V^\vee \otimes A_1^\Gamma)) \otimes_{A_n^\Gamma \otimes A_1^\Gamma} A_{n+1}^\Gamma \otimes_{A_n^\Gamma \otimes A_1^\Gamma} (A_n^\Gamma \otimes (A_1^\Gamma \otimes \wedge^l V^\vee)). \end{aligned}$$

The maps are given by

$$\begin{aligned} &1 \otimes (1 \otimes (1 \otimes w)) \otimes 1 \otimes (1 \otimes (1 \otimes w')) \otimes (1 \otimes (1 \otimes w'')) \otimes 1 \\ &\mapsto (-1)^{lm} 1 \otimes (1 \otimes (1 \otimes w)) \otimes (1 \otimes (1 \otimes w'')) \otimes s_n \otimes (1 \otimes (1 \otimes w')) \\ &\mapsto (-1)^{lm} s_n \otimes (1 \otimes (1 \otimes w')) \omega(w \wedge w'') \end{aligned}$$

where $w \in \wedge^k V^\vee$, $w' \in \wedge^l V^\vee$, $w'' \in \wedge^m V^\vee$. Here we use the fact that the right crossing $T : \text{PQ} \rightarrow \text{QP}$ acts on the resolutions of P and Q just as before, that is, by switching factors and adding a copy of s_n in the middle.

On the other hand, the second composition in (3) is

$$C_1[-1]\{1\} \xrightarrow{TI} C_1[-1]\{1\} \xrightarrow{I\text{adj}} \bigoplus_l A_{n+1}^\Gamma \otimes_{A_n^\Gamma \otimes A_1^\Gamma} (A_n^\Gamma \otimes (A_1^\Gamma \otimes \wedge^l V^\vee))[1]\{-1\}.$$

The maps are given by

$$\begin{aligned} & 1 \otimes (1 \otimes (1 \otimes w)) \otimes 1 \otimes (1 \otimes (1 \otimes w')) \otimes (1 \otimes (1 \otimes w'')) \otimes 1 \\ \mapsto & (-1)^{kl} s_n \otimes (1 \otimes (1 \otimes w')) \otimes 1 \otimes (1 \otimes (1 \otimes w)) \otimes (1 \otimes (1 \otimes w'')) \otimes 1 \\ \mapsto & (-1)^{kl} s_n \otimes (1 \otimes (1 \otimes w')) \omega(w \wedge w''). \end{aligned}$$

As long as $kl \equiv lm \pmod{2}$, this is the same composition as before. The only other possibility is that $k + m \equiv 1 \pmod{2}$, in which case $\omega(w \wedge w'') = 0$ (and thus both sides of (3) vanish). Thus relation (3) holds. Relation (4) is proved similarly.

5.5. Dots and crossings. Next we check that dots move freely through crossings, namely that the following compositions are equal (for simplicity we omit shifts in this section):

- (1) $\text{PP} \xrightarrow{X(b)I} \text{PP} \xrightarrow{T} \text{PP}$ and $\text{PP} \xrightarrow{T} \text{PP} \xrightarrow{IX(b)} \text{PP}$ where $b \in B^\Gamma$
(2) $\text{PP} \xrightarrow{IX(b)} \text{PP} \xrightarrow{T} \text{PP}$ and $\text{PP} \xrightarrow{T} \text{PP} \xrightarrow{X(b)I} \text{PP}$ where $b \in B^\Gamma$.

Notice that the analogous relations involving the other three oriented crossings follow formally from the relations above and the adjunctions from the previous sections.

5.5.1. Relation (1) when $b = \gamma$. The first composition is $C \xrightarrow{X(\gamma)I} C \xrightarrow{T} C$ where $C := A_{n+2}^\Gamma \otimes A_n^\Gamma \otimes A_1^\Gamma \otimes A_1^\Gamma$ ($A_n^\Gamma \otimes \mathbb{k}[\Gamma] \otimes \mathbb{k}[\Gamma]$). The map is given by

$$1 \otimes (1 \otimes 1 \otimes 1) \mapsto 1 \otimes (1 \otimes \gamma \otimes 1) \mapsto s_{n+1} \otimes (1 \otimes 1 \otimes \gamma).$$

Similarly, the second composition $C \xrightarrow{T} C \xrightarrow{IX(\gamma)} C$ is given by

$$1 \otimes (1 \otimes 1 \otimes 1) \mapsto s_{n+1} \otimes (1 \otimes 1 \otimes 1) \mapsto s_{n+1} \otimes (1 \otimes 1 \otimes \gamma).$$

Clearly these two compositions are the same. Relation (2) is proved similarly.

5.5.2. Relation (2) when $b = v$. We first replace each $\mathbb{k}[\Gamma]$ by its resolution. Then T lifts to a map of complexes

$$A_n^\Gamma \otimes (A_1^\Gamma \otimes \wedge^k V^\vee) \otimes (A_1^\Gamma \otimes \wedge^l V^\vee) \rightarrow A_n^\Gamma \otimes (A_1^\Gamma \otimes \wedge^l V^\vee) \otimes (A_1^\Gamma \otimes \wedge^k V^\vee)$$

given by

$$a \otimes (a' \otimes w') \otimes (a'' \otimes w'') \mapsto (-1)^{kl} a \otimes (a'' \otimes w'') \otimes (a' \otimes w')$$

where $w' \in \wedge^k V^\vee$ and $w'' \in \wedge^l V^\vee$.

Now the composition $T \circ X(v)I$ is induced by

$$a \otimes (a' \otimes w') \otimes (a'' \otimes w'') \mapsto a \otimes \phi_v(a' \otimes w') \otimes (a'' \otimes w'') \mapsto (-1)^{(k-1)l} a \otimes (a'' \otimes w'') \otimes \phi_v(a' \otimes w')$$

while $IX(v) \circ T$ is induced by

$$a \otimes (a' \otimes w') \otimes (a'' \otimes w'') \mapsto (-1)^{kl} a \otimes (a'' \otimes w'') \otimes (a' \otimes w') \mapsto (-1)^{kl} a \otimes (a'' \otimes w'') \otimes (-1)^l \phi_v(a' \otimes w').$$

These two compositions are clearly equal which proves relation (1). Relation (2) is proved similarly.

5.6. Composition of crossings relations. First we have the symmetric group relations, namely that the following compositions are equal:

- (1) $PP \xrightarrow{T} PP \xrightarrow{T} PP$ and $PP \xrightarrow{II} PP$
- (2) $PPP \xrightarrow{IT} PPP \xrightarrow{TI} PPP \xrightarrow{IT} PPP$ and $PPP \xrightarrow{TI} PPP \xrightarrow{IT} PPP \xrightarrow{TI} PPP$.



These follow immediately from the definition of T on upward pointing strands, since the action of T is given by multiplication by a simple reflection in the symmetric group.

On the other hand we also have the following relations involving oppositely pointing strands (for simplicity we omit shifts in the rest of this section):

- (1) $PQ \xrightarrow{II} PQ$ and $PQ \xrightarrow{T} QP \xrightarrow{T} PQ$
- (2) the identity $QP \xrightarrow{II} QP$ can be decomposed as the composition $QP \xrightarrow{T} PQ \xrightarrow{T} QP$ plus the sum over a basis of elements $b \in B^\Gamma$ of the composition

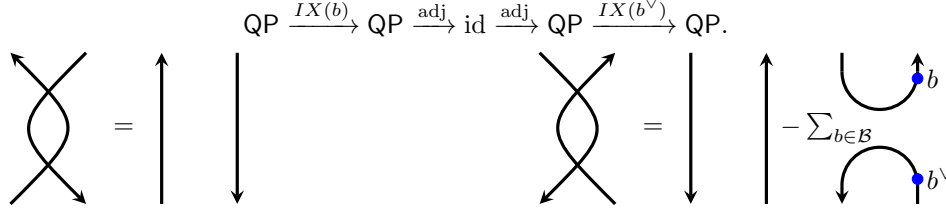

Relation (1) is straight-forward to check. The first composition is $C_1 \xrightarrow{T} C_2 \xrightarrow{T} C_1$ where

$$\begin{aligned} C_1 &:= A_n^\Gamma \otimes_{A_{n-1}^\Gamma \otimes A_1^\Gamma} (A_{n-1}^\Gamma \otimes \mathbb{k}[\Gamma] \otimes \mathbb{k}[\Gamma]) \otimes_{A_{n-1}^\Gamma \otimes A_1^\Gamma} A_n^\Gamma \\ C_2 &:= (A_n^\Gamma \otimes \mathbb{k}[\Gamma]) \otimes_{A_n^\Gamma \otimes A_1^\Gamma} A_{n+1}^\Gamma \otimes_{A_n^\Gamma \otimes A_1^\Gamma} (A_n^\Gamma \otimes \mathbb{k}[\Gamma]). \end{aligned}$$

This composition is given by

$$1 \otimes (1 \otimes 1 \otimes 1) \otimes 1 \mapsto (1 \otimes 1) \otimes s_n \otimes (1 \otimes 1) \mapsto 1 \otimes (1 \otimes 1 \otimes 1) \otimes 1$$

and is thus equal to the identity.

Relation (2) is more interesting. The composition QP is given by the (A_n^Γ, A_n^Γ) -bimodule

$$(A_n^\Gamma \otimes \mathbb{k}[\Gamma]) \otimes_{A_n^\Gamma \otimes A_1^\Gamma} A_{n+1}^\Gamma \otimes_{A_n^\Gamma \otimes A_1^\Gamma} (A_n^\Gamma \otimes \mathbb{k}[\Gamma]).$$

Since the tensor products are derived we need to resolve one copy of $\mathbb{k}[\Gamma]$. We resolve the second copy of $\mathbb{k}[\Gamma]$. We end with a complex where the terms are

$$\bigoplus_{k=0}^2 (A_n^\Gamma \otimes \mathbb{k}[\Gamma]) \otimes_{A_n^\Gamma \otimes A_1^\Gamma} A_{n+1}^\Gamma \otimes_{A_n^\Gamma \otimes A_1^\Gamma} (A_n^\Gamma \otimes (A_1^\Gamma \otimes \wedge^k V^\vee))[k].$$

Now, up to the (A_n^Γ, A_n^Γ) action any element is of the form

$$(1 \otimes \gamma') \otimes 1 \otimes (1 \otimes (1 \otimes w)) \text{ or } (1 \otimes \gamma') \otimes s_n \otimes (1 \otimes (1 \otimes w))$$

where $w \in \wedge^k V^\vee$.

If it is an element of the first form then the differential becomes zero and the map $T : QP \rightarrow PQ$ maps it to zero. On the other hand, suppose $w = w_1$, then the composition

$$QP \xrightarrow{IX(b)} QP \xrightarrow{\text{adj}} \text{id} \xrightarrow{\text{adj}} QP \xrightarrow{IX(b^\vee)} QP$$

where $b = (v, \gamma) \in B^\Gamma$ is zero unless $v \in V$ in which case we get

$$\begin{aligned}
& (1 \otimes \gamma') \otimes 1 \otimes (1 \otimes (1 \otimes w_1)) \\
\begin{array}{c} \xrightarrow{IX(v)} \\ \xrightarrow{IX(\gamma')} \\ \xrightarrow{\text{adj}} \\ \xrightarrow{\text{adj}} \\ \xrightarrow{IX(\gamma^{-1})} \\ \xrightarrow{IX(v^\vee)} \end{array} & (1 \otimes \gamma') \otimes 1 \otimes (1 \otimes (1 \langle v, w_1 \rangle)) \\
& (1 \otimes \gamma') \otimes 1 \otimes (1 \otimes (\gamma \langle v, w_1 \rangle)) \\
& \text{tr}(\gamma' \gamma) \langle v, w_1 \rangle \\
& \text{tr}(\gamma' \gamma) \langle v, w_1 \rangle (1 \otimes 1) \otimes 1 \otimes (1 \otimes (1 \otimes w_1 \wedge w_2)) \\
& \text{tr}(\gamma' \gamma) \langle v, w_1 \rangle (1 \otimes 1) \otimes 1 \otimes (1 \otimes (\gamma^{-1} \otimes w_1 \wedge w_2)) \\
& \text{tr}(\gamma' \gamma) \langle v, w_1 \rangle (1 \otimes 1) \otimes 1 \otimes (1 \otimes (\gamma^{-1} \otimes w_1 \langle w_2, v^\vee \rangle - \gamma^{-1} \otimes w_2 \langle w_1, v^\vee \rangle))
\end{aligned}$$

Now we sum over all $\gamma \in \Gamma$ and over $v = v_1, v_2$. Since $\langle w_i, v_j \rangle = \delta_{ij}$ and $\text{tr}(\gamma' \gamma) = 0$ unless $\gamma' = \gamma^{-1}$ we get

$$\langle v_1, w_1 \rangle (1 \otimes 1) \otimes 1 \otimes (1 \otimes (\gamma' \otimes w_1 \langle w_2, v_2 \rangle - \gamma' \otimes w_2 \langle w_1, v_2 \rangle)) = (1 \otimes \gamma') \otimes 1 \otimes (1 \otimes (1 \otimes w_1)).$$

Thus the composition acts by the identity if $w = w_1$ and similarly if $w = w_2$. Likewise, one can show that it also acts by the identity if $w = 1$ or $w = w_1 \wedge w_2$.

If we are dealing with an element of the second form then it is in the image of the differential unless $k = 0$. So we can assume $k = 0$ in which case we need to consider

$$(1 \otimes \gamma) \otimes s_n \otimes (1 \otimes 1) \in (A_n^\Gamma \otimes \mathbb{k}[\Gamma]) \otimes_{A_n^\Gamma \otimes A_1^\Gamma} A_{n+1}^\Gamma \otimes_{A_n^\Gamma \otimes A_1^\Gamma} (A_n^\Gamma \otimes A_1^\Gamma).$$

The composition involving cups and caps maps it to zero (because the cap takes it to zero). Meanwhile the composition $\text{QP} \xrightarrow{T} \text{PQ} \xrightarrow{T} \text{PQ}$ maps it as follows

$$(1 \otimes \gamma) \otimes s_n \otimes (1 \otimes 1) \mapsto 1 \otimes (1 \otimes 1 \otimes \gamma) \otimes 1 \mapsto (1 \otimes 1) \otimes s_n \otimes (\gamma \otimes 1) = (1 \otimes \gamma) \otimes s_n \otimes (1 \otimes 1).$$

Thus in both cases we see that the sum of the two compositions takes the element to itself. This proves relation (2).

5.7. Counter-clockwise circles and curls. Finally we show that

- (1) the composition $\text{P} \xrightarrow{\text{adj}I} \text{QPP}[-1]\{1\} \xrightarrow{IT} \text{QPP}[-1]\{1\} \xrightarrow{\text{adj}I} \text{P}[-2]\{2\}$ is zero
- (2) the composition

$$\text{id} \xrightarrow{\text{adj}} \text{QP}[-1]\{1\} \xrightarrow{IX(b)} \text{QP}[-1 + |b|]\{1 - |b|\} \xrightarrow{\text{adj}} \text{id}[-2 + |b|]\{2 - |b|\}$$

is equal to $\text{id} \xrightarrow{\text{tr}(b)I} \text{id}$ for any $b \in B^\Gamma$.

$$\begin{array}{c} \uparrow \\ \circlearrowleft \end{array} = 0, \quad \begin{array}{c} \circlearrowleft \\ \bullet \end{array} = \text{tr}(b).$$

The first composition is straight forward and follows for the same reason that the composition $\text{id} \rightarrow \text{QP}[-1]\{1\} \rightarrow \text{id}[-2]\{2\}$ is zero. Alternatively, the left-twist curl is a map $\text{P} \rightarrow \text{P}[-2]\{2\}$ and every such map is zero by degree considerations.

For the second composition we just need to check the case $b = v_1 \wedge v_2$ (see section 3.5). In that case one may note that working \mathbb{k}^\times -equivariantly the only degree zero maps $\text{id} \rightarrow \text{id}$ are given by scalars. The result follows by the remark in the first part of section 3.5.

Alternatively, one can prove the second relation above directly. We must show that the composition

$$\mathrm{id} \xrightarrow{\mathrm{adj}} \mathrm{QP}[-1]\{1\} \xrightarrow{IX(v_1)} \mathrm{QP} \xrightarrow{IX(v_2)} \mathrm{QP}[1]\{-1\} \xrightarrow{\mathrm{adj}} \mathrm{id}$$

is equal to the identity.

The first map is given by

$$\begin{aligned} 1 &\mapsto (1 \otimes 1) \otimes 1 \otimes ((1 \otimes w_1 \wedge w_2) \otimes 1) \\ &\quad - (1 \otimes (w_1 \otimes 1)) \otimes 1 \otimes ((1 \otimes w_2) \otimes 1) + (1 \otimes (w_2 \otimes 1)) \otimes 1 \otimes ((1 \otimes w_1) \otimes 1) \\ &\quad - (1 \otimes (w_1 \wedge w_2 \otimes 1)) \otimes 1 \otimes (1 \otimes 1) \end{aligned}$$

where the right hand terms lie in $\oplus_{k+l=2}(A_n^\Gamma \otimes (\wedge^k V^\vee \otimes A_1^\Gamma)) \otimes_{A_n^\Gamma \otimes A_1^\Gamma} A_{n+1}^\Gamma \otimes_{A_1^\Gamma \otimes A_n^\Gamma} ((A_1^\Gamma \otimes \wedge^l V^\vee) \otimes A_n^\Gamma)$. The only term that survives after acting by $IX(v_1)$ and $IX(v_2)$ is the first one, which is then mapped

$$\begin{aligned} (1 \otimes 1) \otimes 1 \otimes ((1 \otimes w_1 \wedge w_2) \otimes 1) &\xrightarrow{IX(v_1)} (1 \otimes 1) \otimes 1 \otimes ((\langle w_1, v_1 \rangle 1 \otimes w_2 - \langle w_2, v_1 \rangle 1 \otimes w_2) \otimes 1) \\ &\xrightarrow{IX(v_2)} (1 \otimes 1) \otimes 1 \otimes (\langle w_2, v_2 \rangle \langle w_1, v_1 \rangle 1 \otimes 1) \\ &\xrightarrow{\mathrm{adj}} \mathrm{tr}(1)1 = 1. \end{aligned}$$

Here we have used the fact that $\langle w_i, v_j \rangle = \delta_{ij}$.

6. GRAPHICAL CALCULUS AND \mathcal{H}^Γ

6.1. The 2-category \mathcal{H}^Γ . In order to describe the structure of our main object of interest, the 2-category \mathcal{H}_Γ , it is convenient to introduce yet another 2-category \mathcal{H}^Γ .

If Γ is not of type A then $\mathbb{k}[\Gamma]$ will contain blocks of dimension greater than one. However, if one is interested in the representation theory of $\mathbb{k}[\Gamma]$ one can replace each such block with a one dimensional block since any two blocks are Morita equivalent. The advantage is that all blocks are now isomorphic to \mathbb{k} . Informally this is what we do by going from \mathcal{H}_Γ to \mathcal{H}^Γ . Thus \mathcal{H}^Γ will be ‘‘Morita equivalent’’ to \mathcal{H}_Γ but its graphical calculus for 2-morphisms is easier to describe because there are fewer idempotents. Moreover, there is a canonical isomorphism of algebras $K_0(\mathcal{H}^\Gamma) \cong K_0(\mathcal{H}_\Gamma)$ (Proposition 4) and so \mathcal{H}^Γ is also a categorification of \mathfrak{h}_Γ which is of independent interest.

Fix an orientation ϵ of the Dynkin diagram. If vertices i and j are connected by an edge in the diagram, we set $\epsilon_{ij} = 1$ if oriented edge with tail i and head j agrees with the orientation ϵ , and $\epsilon_{ij} = -1$ if the oriented edge with tail i and head j disagrees with ϵ . We also set $\epsilon_{ij} = 0$ if i and j are not connected by an edge. Thus $\epsilon_{ij} = -\epsilon_{ji}$.

We define an additive \mathbb{k} -linear 2-category \mathcal{H}'^Γ as follows. As before, the objects of \mathcal{H}'^Γ are indexed by the integers \mathbb{Z} . The 1-morphisms are generated by objects P_i and Q_i , one for each $i \in I_\Gamma$. Thus a 1-morphism of \mathcal{H}'^Γ is a finite composition (sequence) of P_i 's and Q_j 's.

The space 2-morphisms between two 1-morphisms is the \mathbb{k} -algebra generated by suitable planar diagrams modulo local relations. The diagrams consist of oriented compact one-manifolds (possibly carrying dots and crossings) immersed into the plane strip $\mathbb{R} \times [0, 1]$ modulo isotopies fixing the boundary. Each such strand is labeled by some $i \in I_\Gamma$.

Corresponding to the edge in the Dynkin diagram connecting vertex i to vertex j there is a 2-morphism $X : P_i \rightarrow P_j(1)$ denoted by a solid dot:



These ij dots are allowed to move freely along the one-manifold, including along the cups and caps and through crossings. However, as was the case with degree one dots in \mathcal{H}'_Γ , ij dots (which have degree one) on far away strands anticommute when they move past one another.

For each $i \in I_\Gamma$ we also include as a defining 2-morphism a solid dot on a strand on a strand whose endpoints are both labeled i



and denote this map $X : P_i \rightarrow P_i\langle 2 \rangle$. These ii dots also move freely on strands

There is a relation which governs the composition of dots:

(23)
$$\begin{array}{c} k \\ \uparrow \\ \bullet \\ | \\ j \\ \bullet \\ | \\ i \end{array} = \delta_{ik} \epsilon_{ij} \begin{array}{c} i \\ \uparrow \\ \bullet \\ | \\ i \end{array}$$

Next, we have the following relations analogous to relations (6) - (8). For all $i, j, k \in I_\Gamma$ we have

(24)
$$\begin{array}{c} \diagup \diagdown \\ | \quad | \\ i \quad j \end{array} = \begin{array}{c} \uparrow \\ | \\ i \end{array} \begin{array}{c} \uparrow \\ | \\ j \end{array} \quad \begin{array}{c} \diagup \diagdown \\ \diagdown \diagup \\ | \quad | \quad | \\ i \quad j \quad k \end{array} = \begin{array}{c} \diagup \diagdown \\ \diagdown \diagup \\ | \quad | \quad | \\ i \quad j \quad k \end{array}$$

(25)
$$\begin{array}{c} i \\ \circlearrowleft \\ | \\ i \end{array} = 1 \quad \begin{array}{c} \circlearrowright \\ | \\ i \end{array} = 0.$$

If $i \neq j$ then

(26)
$$\begin{array}{c} \diagup \diagdown \\ | \quad | \\ i \quad j \end{array} = \begin{array}{c} \downarrow \\ | \\ i \end{array} \begin{array}{c} \uparrow \\ | \\ j \end{array} - \epsilon_{ij} \begin{array}{c} i \\ \cup \\ \bullet \\ \cap \\ j \end{array} - \epsilon_{ij} \begin{array}{c} \bullet \\ \cup \\ i \quad j \end{array}$$

while

$$(27) \quad \begin{array}{c} \begin{array}{c} \diagup \quad \diagdown \\ \diagdown \quad \diagup \\ \diagup \quad \diagdown \\ \diagdown \quad \diagup \\ i \quad i \end{array} = \begin{array}{c} \downarrow \\ i \end{array} \begin{array}{c} \uparrow \\ i \end{array} - \begin{array}{c} i \quad i \\ \text{---} \quad \text{---} \\ \diagdown \quad \diagup \\ \text{---} \quad \text{---} \\ i \quad i \end{array} - \begin{array}{c} i \quad i \\ \text{---} \quad \text{---} \\ \diagup \quad \diagdown \\ \text{---} \quad \text{---} \\ i \quad i \end{array} \end{array}$$

We assign a \mathbb{Z} -grading on the space of planar diagrams by defining

$$\begin{array}{c} \text{deg} \begin{array}{c} \diagup \quad \diagdown \\ \diagdown \quad \diagup \end{array} = 0 \\ \text{deg} \begin{array}{c} \text{---} \quad \text{---} \\ \diagdown \quad \diagup \end{array} = \text{deg} \begin{array}{c} \text{---} \quad \text{---} \\ \diagup \quad \diagdown \end{array} = -1 \\ \text{deg} \begin{array}{c} \diagdown \quad \diagup \\ \text{---} \quad \text{---} \end{array} = \text{deg} \begin{array}{c} \diagup \quad \diagdown \\ \text{---} \quad \text{---} \end{array} = 1 \end{array}$$

We define the degree of an ij dot to be one (if $i \neq j$ are joined by an edge) and consequently the degree of an ii dot to be two. Equipped with these assignments all the graphical relations are graded. This provides a \mathbb{Z} -grading on \mathcal{H}'^Γ .

Define \mathcal{H}^Γ to be the Karoubi envelope of \mathcal{H}'^Γ . Since $\mathbb{k}[S_n] \subset \text{End}(P_i^n)$ we let $P_i^\lambda := (P_i^n, e_\lambda)$ where e_λ is the minimal idempotent of $\mathbb{k}[S_n]$ associated to the partition λ of n . We define Q_i^λ similarly.

6.2. The functor $\eta : \mathcal{H}^\Gamma \rightarrow \mathcal{H}_\Gamma$. We will define a functor $\mathcal{H}'^\Gamma \rightarrow \mathcal{H}_\Gamma$ (this induces the functor $\eta : \mathcal{H}^\Gamma \rightarrow \mathcal{H}_\Gamma$ on the idempotent completion of both sides).

To define this functor we map P_i to $(P, e_{i,1})$ and by adjunction Q_i to $(Q, e_{i,1})$. Now the 2-morphism $X : P_i \rightarrow P_i \langle 2 \rangle$ is mapped to the 2-morphism

$$\frac{|\Gamma|}{\dim(V_i)} e_{i,1} \cdot \omega \cdot e_{i,1} : (P, e_{i,1}) \rightarrow (P, e_{i,1}) \langle 2 \rangle$$

(the factor $\frac{|\Gamma|}{\dim(V_i)}$ is there to ensure that the left relation in (25) holds).

Now suppose $i, j \in I_\Gamma$ are joined by an oriented edge $i \rightarrow j$. Then $\text{Hom}_{\mathcal{H}_\Gamma}((P, e_{i,1}), (P, e_{j,1}))$ is one-dimensional, spanned by some map α_{ij} . So we map the dot $X : P_i \rightarrow P_j \langle 1 \rangle$ to some multiple of α_{ij} . To determine this multiple consider the composition

$$\alpha_{ji} \circ \alpha_{ij} : (P, e_{i,1}) \rightarrow (P, e_{i,1}) \langle 2 \rangle$$

which is non-zero because of the structure of B^Γ . Since $\text{Hom}_{\mathcal{H}_\Gamma}((P, e_{i,1}), (P, e_{i,1}))$ is spanned by $e_{i,1} \cdot \omega \cdot e_{i,1}$ this means that $\alpha_{ji} \circ \alpha_{ij}$ equals $e_{i,1} \cdot \omega \cdot e_{i,1}$ up to some non-zero multiple. We rescale α_{ij} so that $\alpha_{ji} \circ \alpha_{ij} = \frac{|\Gamma|}{\dim(V_i)} e_{i,1} \cdot \omega \cdot e_{i,1}$.

Finally, we map crossings $T : P_i P_j \rightarrow P_j P_i$ to crossings $T : (P, e_{i,1})(P, e_{j,1}) \rightarrow (P, e_{j,1})(P, e_{i,1})$.

Proposition 3. *The above morphisms define a functor $\eta : \mathcal{H}^\Gamma \rightarrow \mathcal{H}_\Gamma$.*

Proof. We need to check relations (23) - (27). Relations (24) and the right hand relation in (25) are clear. The left hand relation in (25) holds since

$$\text{tr}(\omega \cdot e_{i,1}) = \frac{\dim(V_i)}{|\Gamma|}$$

and we mapped $X : P_i \rightarrow P_i \langle 2 \rangle$ to $\frac{|\Gamma|}{\dim(V_i)} e_{i,1} \cdot \omega \cdot e_{i,1}$.

Relation (23) holds by definition if $\epsilon_{ij} = 1$. If $\epsilon_{ij} = -1$ then $\epsilon_{ji} = 1$ and so we have

$$\mathbf{1} = \begin{array}{c} i \\ \circlearrowleft \\ i \end{array} = \begin{array}{c} i \\ \circlearrowleft \quad \bullet \\ \bullet \\ i \end{array} j = - \begin{array}{c} j \\ \circlearrowleft \quad \bullet \\ \bullet \\ j \end{array} i$$

where we use relation (23) to obtain the second equality and the minus sign appears when one passes the two degree one dots past each other. It follows that

$$\alpha_{ij} \circ \alpha_{ji} = -\alpha_{ji} \circ \alpha_{ij} = -\frac{|\Gamma|}{\dim(V_i)} e_{i,1} \cdot \omega \cdot e_{i,1}$$

which proves relation (23) when $\epsilon_{ij} = -1$.

Next we prove relation (27). This follows from the left relation in (7) in the definition of \mathcal{H}'_Γ . More precisely, multiply endpoints of all strands of the left relation in (7) by the idempotent $e_{i,1}$. Now $e_{i,1} b e_{i,1} = 0$ unless b has degree zero or two. Now if b has degree zero then it belongs to $\mathbb{k}[\Gamma]$. We use the basis of $\mathbb{k}[\Gamma]$ consisting of matrix units b which are zero everywhere except in one entry. Then $e_{i,1} b e_{i,1} = 0$ unless $b = e_{i,1}$. Thus the sum in (7) collapses and we get only one term corresponding to $b = e_{i,1}$.

Similarly, if b has degree two then the sum collapses and we get the term $b = (\omega, e_{i,1})$. Now

$$e_{i,1}^\vee = \frac{|\Gamma|}{\dim(V_i)} e_{i,1} \cdot \omega \cdot e_{i,1}$$

since $\text{tr}(\omega \cdot e_{i,1}) = \frac{\dim(V_i)}{|\Gamma|}$. This is precisely the image of $X : P_i \rightarrow P_i \langle 2 \rangle$ under η . Thus we get relation (27).

Finally, relation (26) is similar. In this case only one of the terms in the sum in (7) survives. To compute the coefficient $-\epsilon_{ij}$, cap off everything with a cap containing an ij dot and use relations (23) and (25). \square

We will prove in section 7 that η induces an isomorphism on Grothendieck groups:

Proposition 4. *The functor η induces an isomorphism*

$$K_0(\eta) : K_0(\mathcal{H}^\Gamma) \longrightarrow K_0(\mathcal{H}_\Gamma).$$

Remark 6.1. Proposition 4 says that both \mathcal{H}^Γ and \mathcal{H}_Γ categorify the Heisenberg algebra \mathfrak{h}_Γ . However, the 2-categories \mathcal{H}^Γ and \mathcal{H}_Γ are not equivalent, but are rather ‘‘Morita equivalent’’, meaning that the endomorphism rings appearing in \mathcal{H}_Γ and \mathcal{H}^Γ are Morita equivalent. This means that the 2-representation theory of \mathcal{H}^Γ and \mathcal{H}_Γ are equivalent.

6.3. Proposition 2 for \mathcal{H}^Γ . In this section we prove that relations from Proposition 2 hold in $K_0(\mathcal{H}^\Gamma)$.

Recall the idempotent corresponding to the trivial representation in $\mathbb{k}[S_n]$

$$e_{triv} = \frac{1}{n!} \sum_{g \in S_n} g.$$

The idempotent e_{triv} defines the summand $P_i^{(n)} = (P_i^n, e_{triv})$ of P_i^n in the category \mathcal{H}^Γ . These idempotents also define $Q_i^{(n)}$ by adjunction. We will draw e_{triv} as a white rectangle labeled by i^n . We will also write a single line connecting two such rectangles instead of n lines, for simplicity. Thus the

identity 2-morphism of $P_i^{(n)}$ is drawn as one of the pictures

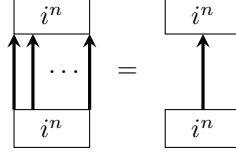

depending on whether or not we wish to emphasize the fact that there are multiple lines entering and exiting the rectangle.

We first prove that

$$P_i^{(n)} P_j^{(m)} \cong P_j^{(m)} P_i^{(n)} \text{ for all } i, j \in I_\Gamma.$$

The isomorphism is given by the 2-morphism

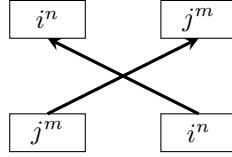

with inverse given by

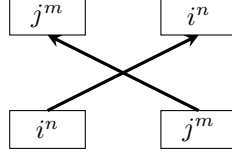

Since we can pull strands apart using the left hand relation in (24) it is easy to see that these two 2-morphisms are inverse of each other. The proof that

$$Q_i^{(n)} Q_j^{(m)} \cong Q_j^{(m)} Q_i^{(n)} \text{ for all } i, j \in I_\Gamma$$

is the same except that all strands now point downwards.

The proof that $Q_i^{(n)} P_j^{(m)} \cong P_j^{(m)} Q_i^{(n)}$ when i and j are not connected by an edge also follows via the same computation using relation (26).

Next we show the more interesting relation

$$Q_i^{(n)} P_i^{(m)} \cong \bigoplus_{k \geq 0} P_i^{(m-k)} Q_i^{(n-k)} \otimes H^*(\mathbb{P}^k) \text{ for all } i \in I_\Gamma.$$

To define maps $Q_i^{(n)} P_i^{(m)} \rightarrow P_i^{(m-k)} Q_i^{(n-k)}$ consider the 2-morphisms

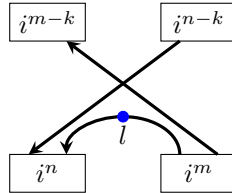

where $0 \leq l \leq k$. In this picture k of the strands coming out from the bottom are involved in the k caps while the other strands are involved in crossings. The l tells us that we put a single ii dot on the first l of the k caps (because we have the idempotents it does not matter on which l strands we place the dots).

Taking the direct sum as l ranges from 0 to k , defines a 2-morphism from

$$Q_i^{(n)} P_i^{(m)} \rightarrow P_i^{(m-k)} Q_i^{(n-k)} \otimes H^*(\mathbb{P}^k).$$

Taking the direct sum over k we obtain a 2-morphism

$$f : Q_i^{(n)} P_i^{(m)} \longrightarrow \oplus_{k \geq 0} P_i^{(m-k)} Q_i^{(n-k)} \otimes H^*(\mathbb{P}^k).$$

We claim this morphism is invertible and we explicitly construct its inverse as a linear combinations of diagrams of the form

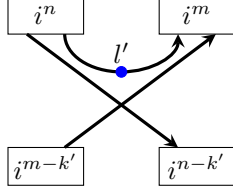

where we put l' dots on l' of the k' cup-like strands.

To do this we first compute the following graphical relation in $\text{End}(Q_i^{(n)} P_i^{(m)})$:

$$\sum_{0 \leq l \leq k} c_{m,n}^{k,l} \begin{array}{c} \begin{array}{cc} \boxed{i^n} & \boxed{i^m} \\ \swarrow & \searrow \\ \boxed{i^{m-k}} & \boxed{i^{n-k}} \\ \swarrow & \searrow \\ \boxed{i^n} & \boxed{i^m} \end{array} \\ \begin{array}{c} \text{cup with } l \text{ dots} \end{array} \end{array} = \begin{array}{cc} \boxed{i^n} & \boxed{i^m} \\ \downarrow & \uparrow \\ \boxed{i^n} & \boxed{i^m} \end{array}$$

(28)

where $c_{m,n}^{k,l} = k! \binom{m}{k} \binom{n}{k} \binom{k}{l}$.

To see where this relation comes from consider the $k = 0$ term in the left hand side (it has no cups, caps, or dots in it). Expanding the idempotents $\boxed{i^n}$ and $\boxed{i^m}$ explicitly as a sum of permutations we rewrite the $k = 0$ term as a linear combination of diagrams with many crossings. Then crossings involving two upward pointing strands or two downward pointing strands can be absorbed into the idempotents at the top or bottom of the diagram (notice that this is a consequence of using the idempotent e_{triv} , which satisfies $\sigma e_{triv} = e_{triv} \sigma = e_{triv}$ for any permutation σ). Thus we write the $k = 0$ term as a diagram with no idempotents in the middle:

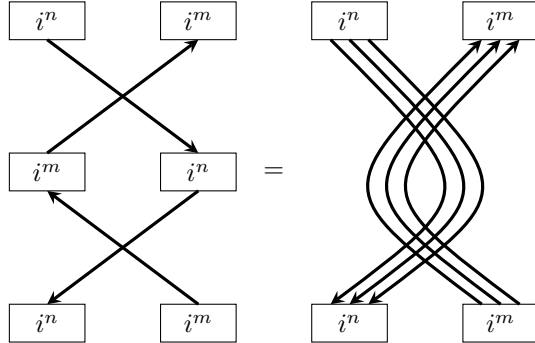

In both sides of the above picture there are n strands emanating from an idempotent $\boxed{i^n}$ and in the right hand side we have drawn more than one of these strands to emphasize the fact that there are many crossings.

More generally we use the relation

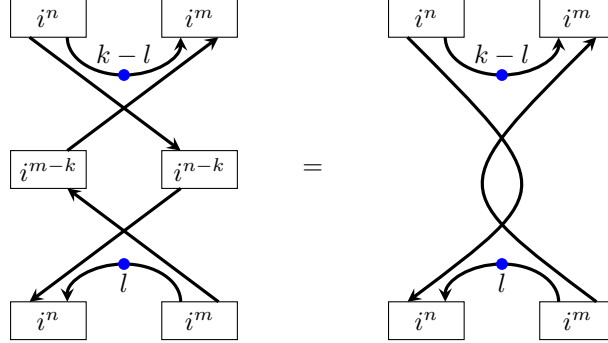

to write the entire left hand side of equation (28) as a linear combination of diagrams without up-up or down-down crossings.

Now we start pulling apart the inner double crossings in each term one at a time using the relation (27). At every stage we absorb newly created upward (or downward) pointing crossings in to the top (or bottom) idempotents. The result is a linear combination of diagrams of the form

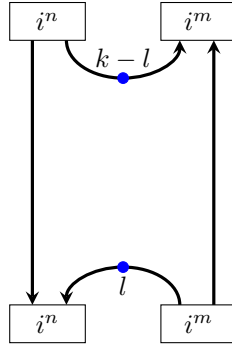

Keeping track of the constants carefully one arrives at equation (28). The particular values of the constants $c_{m,n}^{k,l}$ are not really important apart from the fact that they are non-zero. The key observation which follows from equation (28) is that the identity 2-morphism of $Q_i^{(n)}P_i^{(m)}$ factors through $P_i^{(m-k)}Q_i^{(n-k)} \otimes H^*(\mathbb{P}^k)$ as a composition of 2-morphisms

$$\text{id} : Q_i^{(n)}P_i^{(m)} \xrightarrow{f} P_i^{(m-k)}Q_i^{(n-k)} \otimes H^*(\mathbb{P}^k) \xrightarrow{g} Q_i^{(n)}P_i^{(m)}$$

where

$$f = \sum_{0 \leq l \leq k} \text{diagram}$$

and

$$g = \sum_{0 \leq l \leq k} c_{m,n}^{k,l}$$

In addition, a similar graphical manipulation shows that

$$(29) \quad \begin{array}{ccc} \begin{array}{cc} i^{m-k} & i^{n-k} \\ \swarrow & \searrow \\ i^n & i^m \\ \swarrow & \searrow \\ i^{m-k'} & i^{n-k'} \end{array} & = & \frac{\delta_{k,k'} \delta_{l,l'}}{c_{k,l}^{m,n}} \begin{array}{cc} i^{m-k} & i^{n-k} \\ \uparrow & \downarrow \\ i^{m-k} & i^{n-k} \end{array} \end{array}$$

The fact that the left hand side is zero when $l \neq l'$ follows from the fact that when the middle idempotents are expanded as a linear combination of permutations, each term contains either a left twist curl (which is zero) or a strand with two ii dots on it (which is also zero).

It follows from equation (29) that the identity 2-morphism of $\oplus_{k \geq 0} P_i^{(m-k)} Q_i^{(n-k)} \otimes H^*(\mathbb{P}^k)$ factors as

$$\text{id} : \oplus_{k \geq 0} P_i^{(m-k)} Q_i^{(n-k)} \otimes H^*(\mathbb{P}^k) \xrightarrow{g} Q_i^{(n)} P_i^{(m)} \xrightarrow{f} \oplus_{k \geq 0} P_i^{(m-k)} Q_i^{(n-k)} \otimes H^*(\mathbb{P}^k),$$

while the identity 2-morphism of $Q_i^{(n)} P_i^{(m)}$ factors as $f \circ g$. Thus f and g are inverse isomorphisms, as desired.

The proof that $Q_j^{(n)} P_i^{(m)} \cong \oplus_{k \geq 0} P_i^{(m-k)} Q_j^{(n-k)}$ when $i, j \in I_\Gamma$ are connected by an edge is very similar to the above. In particular, the isomorphism from the left hand side to the right hand side is given by

$$f' = \sum_{k \geq 0}$$

In the above picture each of the k caps carries an ij dot. \square

The above proof of Proposition 2 was carried out in the category \mathcal{H}^Γ . By applying the functor η , however, it follows immediately that the same proposition holds in the category \mathcal{H}_Γ , since any isomorphisms and direct sum decompositions which hold for 1-morphisms in \mathcal{H}^Γ also hold in the image.

6.4. Relation to Hilbert schemes. We end this section by explaining how \mathcal{H}^Γ acts on the derived categories of coherent sheaves on Hilbert schemes of points on the corresponding ALE space.

We take $\mathbb{k} = \mathbb{C}$. If $\Gamma \subset SL_2(\mathbb{C})$ is finite then by the McKay correspondence the derived category of finite dimensional left $\text{Sym}^* V^\vee \rtimes \Gamma$ -modules is isomorphic to the derived category $DCoh(Y_\Gamma)$ of coherent sheaves on the resolution $Y_\Gamma := \widehat{\mathbb{C}^2/\Gamma}$ of the quotient \mathbb{C}^2/Γ .

Now by the results of Bridgeland, King and Reid [BKR] the derived category \mathcal{C}_n^Γ of $A_n^\Gamma = (\text{Sym}^* V^\vee \times \Gamma)^{\otimes n} \times S_n$ modules is isomorphic to the derived category of coherent sheaves on the S_n -equivariant Hilbert scheme $\text{Hilb}^{S_n}(Y_\Gamma^n)$. This Hilbert schemes parametrizes S_n -equivariant subschemes of Y_Γ^n whose global sections are isomorphic to the regular representation of S_n . By work of Haiman [H] $\text{Hilb}^{S_n}(Y_\Gamma^n)$ is isomorphic to the usual Hilbert scheme of points $\text{Hilb}^n(Y_\Gamma)$.

Hence Theorem 2 gives a categorical Heisenberg action of \mathcal{H}^Γ on $\bigoplus_n DCoh(\text{Hilb}^n(Y_\Gamma))$. If $\Gamma = \mathbb{C}^\times$ then we should think of \mathcal{C}_n^Γ as the derived category of coherent sheaves on the Hilbert scheme of the quotient stack $[\mathbb{C}^2/\mathbb{C}^\times]$.

We would like to sketch what this action of \mathcal{H}^Γ on $\bigoplus_n DCoh(\text{Hilb}^n(Y_\Gamma))$ looks like geometrically. Inside $\text{Hilb}^n(Y_\Gamma) \times \text{Hilb}^{n+1}(Y_\Gamma)$ we have the natural subvariety consisting of ideal sheaves (J_1, J_2) where $J_2 \subset J_1$. This subvariety also maps to Y_Γ by taking the quotient J_1/J_2 and subsequently induces a functor $DCoh(\text{Hilb}^n(Y_\Gamma) \times Y_\Gamma) \rightarrow DCoh(\text{Hilb}^{n+1}(Y_\Gamma))$. Under the correspondence above this functor is induced by the $(A_{n+1}^\Gamma, A_n^\Gamma \times A_1^\Gamma)$ -bimodule A_{n+1}^Γ (where we use the usual inclusion of $A_n^\Gamma \otimes A_1^\Gamma$ into A_{n+1}^Γ).

On the other hand, the exceptional fibre of Y_Γ contains one copy E_i of \mathbb{P}^1 for each $i \in I_\Gamma$ except for the node which corresponds to the trivial Γ -representation (we label this node 0 and the corresponding minimal idempotent e_0). Under the McKay correspondence each A_1^Γ -module $\mathbb{k}[\Gamma]e_i$ corresponds to the sheaf $\mathcal{O}_{E_i}(-1)$ while $\mathbb{k}[\Gamma]e_0$ corresponds to the structure sheaf $\mathcal{O}_{\cup_i E_i}[-1]$ shifted into cohomological degree one. We will use the notation $E_0 := \cup_i E_i$.

Now the functor $P_i : \mathcal{C}_n^\Gamma \rightarrow \mathcal{C}_{n+1}^\Gamma$ in \mathcal{H}^Γ is induced by $A_{n+1}^\Gamma \otimes_{A_n^\Gamma \otimes A_1^\Gamma} (A_n^\Gamma \otimes \mathbb{k}[\Gamma]e_i)$. It follows that the corresponding functor $P_i : \text{Hilb}^n(Y_\Gamma) \rightarrow \text{Hilb}^{n+1}(Y_\Gamma)$ is induced by the kernels

$$\mathcal{O}_{P_i(n, n+1)} \otimes \pi^* \mathcal{O}_{\mathbb{P}^1}(-1) \text{ if } i \neq 0 \text{ and } \mathcal{O}_{P_0(n, n+1)}[-1] \text{ if } i = 0.$$

Here $P_i(n, n+1)$ denotes the variety

$$\{(J_1, J_2) : \text{supp}(J_1/J_2) \in E_i\} \subset \text{Hilb}^n(Y_\Gamma) \times \text{Hilb}^{n+1}(Y_\Gamma)$$

and if $i \neq 0$ we have the natural projection map $\pi : P_i(n, n+1) \rightarrow E_i \cong \mathbb{P}^1$ which remembers the support point $\text{supp}(J_1/J_2)$. The functors $Q_i : \text{Hilb}^{n+1}(Y_\Gamma) \rightarrow \text{Hilb}^n(Y_\Gamma)$ are given by the adjoint of P_i (up to a shift).

The fundamental class of the variety $P_i(n, n+1)$ induces one of Nakajima's Heisenberg operators on the cohomology of Hilbert schemes. The other Nakajima operators are given by fundamental classes of the varieties

$$P_i(n, n+k) = \{(J_1, J_2) : \text{supp}(J_1/J_2) \text{ is supported at a single point of } E_i\} \subset \text{Hilb}^n(Y_\Gamma) \times \text{Hilb}^{n+k}(Y_\Gamma).$$

Nakajima's theorem [N1] is that fundamental classes of the $P_i(n, n+k)$ (and their Poincaré duals) satisfy the defining relations of the "standard" Heisenberg generators $a_i(k)$ from section 2. However, when $k > 1$ the varieties $P_i(n, n+k)$ are singular, a fact which perhaps accounts for some of the difficulty of lifting the Nakajima action on cohomology to K-theory. In our categorical approach, the Heisenberg generators which are most easily categorified are not the standard generators $a_i(k)$ but rather the generators $p_i^{(k)}$ which are categorified by the direct summands $P_i^{(k)}$ of P_i^k .

Remark 6.2. The graded version of the story above is given by the equivalence

$$D(A_n^\Gamma\text{-gmod}) \cong DCoh^{\mathbb{C}^\times}(\text{Hilb}^n(Y_\Gamma))$$

where the right side is the derived category of \mathbb{C}^\times equivariant sheaves. Here the action of \mathbb{C}^\times on $\text{Hilb}^n(Y_\Gamma)$ is induced from the diagonal action of \mathbb{C}^\times on \mathbb{C}^2 .

7. PROOF OF MAIN THEOREM 1

In this section we study the sequence of maps

$$\mathfrak{h}_\Gamma \xrightarrow{\pi} K_0(\mathcal{H}^\Gamma) \xrightarrow{K_0(\eta)} K_0(\mathcal{H}_\Gamma) \rightarrow \text{End}(\bigoplus_{n \geq 0} K_0(\mathcal{C}_n^\Gamma)) \simeq \text{End}(\mathcal{F})$$

where \mathcal{F} is isomorphic to the Fock space representation of \mathfrak{h}_Γ . We will show that both π and $K_0(\eta)$ are isomorphisms, thus proving Proposition 4 and Theorem 1. In particular, this shows that both \mathcal{H}_Γ and \mathcal{H}^Γ categorify \mathfrak{h}_Γ .

We begin with some preliminary results.

Lemma 3. *There are no negative degree endomorphisms of $\prod_i P_i^{m_i} \prod_i Q_i^{n_i}$ while the algebra of degree zero endomorphisms is isomorphic to $\otimes_i \mathbb{k}[S_{m_i}] \otimes_i \mathbb{k}[S_{n_i}]$.*

Proof. Any negative degree endomorphism must contain a left-oriented cap or right oriented cup (since these are the only generating 2-morphisms of negative degree). Such a cup or cap is either part of a left-twist curl (which makes the entire picture equal to zero) or part of a counter-clockwise circle. However, by the defining relations, the only non-zero counter-clockwise circles are those of non-negative degree (i.e. those carrying dots of degree two). Thus any negative degree endomorphism must be zero.

Note that this argument would not apply to endomorphisms of a 1-morphism which contains a P to the right of a Q . For example, a left-oriented cap followed by a right oriented cap is a non-zero degree -2 endomorphism of $Q_i P_i$.

By the same argument any degree zero diagram describing an endomorphism of $\prod_i P_i^{m_i} \prod_i Q_i^{n_i}$ cannot have any right-twist curls or dots thus must be isotopic to a sum of braid-like diagrams (i.e. diagrams with no local minima or maxima and no dots) connecting a P_i to a P_i or a Q_i to Q_i . The result now follows. \square

Proposition 5. *Any 1-morphism in \mathcal{H}^Γ decomposes uniquely into a finite direct sum of indecomposables. The indecomposable 1-morphisms in \mathcal{H}^Γ are of the form $\prod_i P_i^{\lambda_i} \prod_i Q_i^{\mu_i}$ for some partitions $\{\lambda_i, \mu_i\}$.*

Proof. Lemma 3 implies that the space of endomorphisms (of a fixed degree) of any 1-morphism is finite dimensional. This means that \mathcal{H}^Γ satisfies the Krull-Schmidt property and hence any 1-morphism decomposes uniquely into a finite direct sum of indecomposables.

Now any 1-morphism in \mathcal{H}^Γ is a direct summand of a sequence of P_i 's and Q_i 's. Using relations from Proposition 1 (which were shown to hold for \mathcal{H}^Γ in section 6.3) it follows that any 1-morphism is a direct sum of (shifts of) 1-morphisms of the form $\prod_i P_i^{\lambda_i} \prod_i Q_i^{\mu_i}$. It remains to show that such endomorphisms are indecomposable.

But this follows from Lemma 3 since $\prod_i P_i^{\lambda_i} \prod_i Q_i^{\mu_i}$ is a direct summand of $\prod_i P_i^{|\lambda_i|} \prod_i Q_i^{|\mu_i|}$ corresponding to the minimal idempotent $\prod_i e_{\lambda_i, 1} \prod_i e_{\mu_i, 1} \in \otimes_i \mathbb{k}[S_{|\lambda_i|}] \otimes_i \mathbb{k}[S_{|\mu_i|}]$. \square

Remark 7.1. Arguing as above it is straightforward to check that the 1-morphisms $P^\lambda Q^\mu$ for all I_Γ -colored partitions λ and μ form a complete set of indecomposable 1-morphisms in \mathcal{H}_Γ .

Lemma 4. *In \mathcal{H}^Γ we have $P_i^\lambda \cdot P_i \cong \bigoplus_\mu P_i^\mu$ where the sum is over all μ such that $|\mu| = |\lambda| + 1$ and $\lambda \subset \mu$.*

Proof. The key is the following well-known fact about representations of the symmetric group: the irreducible representation V_λ of S_n , when induced to S_{n+1} , decomposes as a direct sum of irreducible representations V_μ , where $|\mu| = |\lambda| + 1$ and $\lambda \subset \mu$; moreover, each such irreducible V_μ occurs with multiplicity one.

This fact can be restated in the language of idempotents. Let $e_\lambda \in \mathbb{k}[S_n]$ denote a minimal idempotent corresponding to the irreducible representation V_λ . Consider $1 \otimes e_\lambda \in \mathbb{k}[S_{n+1}] \otimes_{\mathbb{k}[S_n]} \mathbb{k}[S_n] \cong$

$\mathbb{k}[S_{n+1}]$. This idempotent corresponds to the induced module $\text{Ind}_{S_n}^{S_{n+1}}(V_\lambda)$. Then we have an equality

$$1 \otimes e_\lambda = \sum_{\mu \vdash n+1: \lambda \subset \mu} e_\mu,$$

where $e_\mu \in \mathbb{k}[S_{n+1}]$ is an idempotent corresponding to the irreducible representation V_μ of S_{n+1} . Under the embeddings

$$\mathbb{k}[S_n] \hookrightarrow \text{End}_{\mathcal{H}\Gamma}(P_i^n), \quad \mathbb{k}[S_{n+1}] \hookrightarrow \text{End}_{\mathcal{H}\Gamma}(P_i^{n+1})$$

this implies the decomposition in the Lemma. \square

Corollary 1. *The classes $\{[P_i^{(m)}], [Q_j^{(n)}] : i, j \in I_\Gamma, n, m \geq 0\}$ generate $K_0(\mathcal{H}^\Gamma)$ as an algebra.*

Proof. By Proposition 5 above $K_0(\mathcal{H}^\Gamma)$ is spanned by elements of the form $\prod [P_i^{\lambda_i}] \prod [Q_i^{\mu_i}]$. Thus it suffices to show that any $[P_i^\lambda]$ is generated by $\{[P_i^{(m)}] : m \geq 0\}$. This follows by induction using Lemma 4. For instance,

$$P_i^2 = P_i^{(2)} \oplus P_i^{(1^2)}$$

so that $P_i^{(1^2)}$ is generated by P_i and $P_i^{(2)}$. \square

Remark 7.2. The expression of $[P_i^\lambda]$ in terms of $[P_i^{(m)}]$'s is given by the Giambelli identity expressing the Schur polynomial in terms of products of elementary symmetric functions. Explicitly,

$$[P_i^\lambda] = \det_{kl} [P_i^{\lambda'_k + k - l}],$$

where $\lambda' = (\lambda'_1 \geq \lambda'_2 \geq \dots)$ is the transpose of the partition λ .

In order to prove Proposition 4 and Theorem 1, we now consider the sequence

$$\mathfrak{h}_\Gamma \xrightarrow{\pi} K_0(\mathcal{H}^\Gamma) \xrightarrow{K_0(\eta)} K_0(\mathcal{H}_\Gamma) \rightarrow \text{End}(\bigoplus_{n \geq 0} K_0(\mathcal{C}_n^\Gamma)) \simeq \text{End}(\mathcal{F})$$

and show that both π and $K_0(\eta)$ are isomorphisms.

First we check that π is injective. This follows since the Fock space representation of \mathfrak{h}_Γ is faithful, which in turn follows easily from its description as differential operators acting on a polynomial algebra, [FJW, FJW2]. Thus the composition of all maps in the above sequence is injective, which implies that π is injective.

Next we check that π is surjective. Note that by Lemma 1 $K_0(\mathcal{H}^\Gamma)$ is generated as an algebra by the classes $[P_i^{(m)}]$ and $[Q_j^{(n)}]$. Since $\pi(p_i^{(m)}) = [P_i^{(m)}]$ and $\pi(q_j^{(n)}) = [Q_j^{(n)}]$ these generators are in the image of π . Thus π is surjective.

Since π is surjective and the total composition injective it follows that $K_0(\eta)$ is injective. Finally it is easy to see $K_0(\eta)$ is surjective using Remark 7.1. \square

8. AN ABELIAN 2-REPRESENTATION OF \mathcal{H}_Γ

We now describe another 2-representation of \mathcal{H}_Γ which is closely related to the 2-representation of section 4 on $\bigoplus_n D(A_n^\Gamma\text{-gmod})$. More precisely we replace A_n^Γ with its Koszul dual

$$B_n^\Gamma := (B^\Gamma \otimes \dots \otimes B^\Gamma) \rtimes S_n.$$

(The algebra B_n^Γ can also be written in smash product notation as $(B^\Gamma)^{\otimes n} \# \mathbb{k}[S_n]$.) The algebras B_n^Γ are superalgebras, and it turns out that the Heisenberg category \mathcal{H}_Γ acts on the module category $\bigoplus_n B_n^\Gamma\text{-gmod}$. Moreover, this action is non-derived and is therefore, in some sense, simpler than the action from section 4. However, we have emphasized the action in 4 because of its closer relationship to geometry.

After recalling some basic definitions of superalgebras and modules over them, we will define all the generating 1 and 2-morphisms. The verification of relations, which is straightforward, will be left to the reader.

8.1. Superalgebras and supermodules. Let B be a superalgebra. A left module over B is a supervector space W which is a left B module in the usual sense. A right supermodule is a supervector space which is a right B module in the usual sense.

Given two superalgebras B_1 and B_2 , we form the tensor product superalgebra $B_1 \otimes B_2$ with multiplication

$$(a \otimes b)(a' \otimes b') = (-1)^{|b||a'|} (aa' \otimes bb').$$

There is an isomorphism of superalgebras

$$B_1 \otimes B_2 \cong B_2 \otimes B_1, \quad a \otimes b \mapsto (-1)^{|a||b|} b \otimes a.$$

If V and W are left supermodules for B_1 and B_2 respectively, then $W_1 \otimes W_2$ is a left supermodule for the superalgebra $B_1 \otimes B_2$. As a vector space, $W_1 \otimes W_2$ is the ordinary vector space tensor product. The action of $B_1 \otimes B_2$ on $W_1 \otimes W_2$ is

$$a \otimes b \cdot (v \otimes w) = (-1)^{|b||v|} (a \cdot v) \otimes (b \cdot w).$$

A morphism of left B supermodules $f : W_1 \rightarrow W_2$ is a map of vector spaces such that

$$f(a \cdot v) = (-1)^{|f||a|} f(v).$$

Here $|f|$ is the degree of f considered as a map of super vector spaces. In contrast, a morphism of right B supermodules $g : W_1 \rightarrow W_2$ is a map of vector spaces such that

$$g(v \cdot a) = g(v) \cdot a.$$

Note there is no sign here.

If $f : W_1 \rightarrow W_2$ is a morphism of left B_1 supermodules and $g : W'_1 \rightarrow W'_2$ is a morphism of left B_2 supermodules, then we write $f \otimes g$ as the induced morphism of left $B_1 \otimes B_2$ modules

$$(f \otimes g) : W_1 \otimes W'_1 \longrightarrow W_2 \otimes W'_2.$$

Explicitly, we have

$$(30) \quad (f \otimes g)(v \otimes w) = (-1)^{|g||v|} f(v) \otimes g(w).$$

A (B_1, B_2) superbimodule W is a left B_1 supermodule which is a right B_2 supermodule for the same grading, such that

$$a \cdot (v \cdot b) = (a \cdot v) \cdot b.$$

A morphism of superbimodules is a map which is a morphism of left and right supermodules. For the remainder of this section, all objects will be assumed super though we will often omit writing the prefix “super” from discussions of algebras, modules and bimodules.

8.2. The algebras B_n^Γ . Recall the algebra

$$B_n^\Gamma := (B^\Gamma \otimes \dots \otimes B^\Gamma) \rtimes S_n,$$

which is the Koszul dual of A_n^Γ . B_n^Γ contains both $\mathbb{k}[S_n]$ and $B^{\Gamma^{\otimes n}}$ as subalgebras, and the action of S_n on $B^{\Gamma^{\otimes n}}$ is by superpermutations: if $s_k \in S_n$ is the simple transposition $(k, k+1)$, then

$$s_k \cdot (b_1 \otimes \dots \otimes b_k \otimes b_{k+1} \otimes \dots \otimes b_n) = (-1)^{|b_k||b_{k+1}|} b_1 \otimes \dots \otimes b_{k+1} \otimes b_k \otimes \dots \otimes b_n.$$

8.3. Functors P and Q. Consider the natural inclusion $B_n^\Gamma \hookrightarrow B_{n+1}^\Gamma$. We let $P^\Gamma(n)$ and $(n)Q^\Gamma$ denote $B_{n+1}^\Gamma\{1\}$ and B_{n+1}^Γ thought of as a $(B_{n+1}^\Gamma, B_n^\Gamma)$ bimodule and $(B_n^\Gamma, B_{n+1}^\Gamma)$ bimodule respectively.

Now $\mathbb{k}[S_{n+1}]$ is a flat $\mathbb{k}[S_n]$ module where the module structure is defined via the natural inclusion $\mathbb{k}[S_n] \rightarrow \mathbb{k}[S_{n+1}]$. Subsequently B_{n+1}^Γ is a flat B_n^Γ module. It follows that we can define functors

$$P(n) : B_n^\Gamma\text{-gmod} \longrightarrow B_{n+1}^\Gamma\text{-gmod} \text{ and } (n)Q : B_{n+1}^\Gamma\text{-gmod} \longrightarrow B_n^\Gamma\text{-gmod}$$

between abelian categories (instead of derived categories) using

$$P(n)(\cdot) := P^\Gamma(n) \otimes_{B_n^\Gamma} (\cdot) \text{ and } (n)Q(\cdot) := (n)Q^\Gamma \otimes_{B_{n+1}^\Gamma} (\cdot).$$

As before we usually omit the (n) to simplify notation.

8.4. Natural Transformations.

8.4.1. Definition of X. For any $n \geq 1$ there is an inclusion $B_1^\Gamma \hookrightarrow B_n^\Gamma$ given by sending an element of B_1^Γ to the last factor of the product

$$a \mapsto (1 \otimes 1 \otimes \dots \otimes 1 \otimes a) \in B_n^\Gamma.$$

The image of this inclusion supercommutes with the subalgebra $B_{n-1}^\Gamma \subset B_n^\Gamma$. We henceforth consider B_1^Γ as a subalgebra of B_n^Γ via this embedding. For homogeneous $b \in B_1^\Gamma$ we define

$$X(b) : B_n^\Gamma \longrightarrow B_n^\Gamma \quad w \mapsto (-1)^{|w||b|} wb$$

using right multiplication by $b \in B_1^\Gamma \subset B_n^\Gamma$.

The map $X(b)$ is a map of $(B_n^\Gamma, B_{n-1}^\Gamma)$ bimodules. We thus get a well-defined natural transformation

$$X(b) : P \longrightarrow P\{\deg b\}.$$

8.4.2. Definition of T. Notice that $PP : B_n^\Gamma\text{-gmod} \rightarrow B_{n+2}^\Gamma\text{-gmod}$ is induced by the $(B_{n+2}^\Gamma, B_n^\Gamma)$ bimodule

$$B_{n+2}^\Gamma\{1\} \otimes_{B_{n+1}^\Gamma} B_{n+1}^\Gamma\{1\} \cong B_{n+2}^\Gamma\{2\}.$$

So to define a degree zero map $T : PP \rightarrow PP$ we need a map $B_{n+2}^\Gamma \rightarrow B_{n+2}^\Gamma$ of $(B_{n+2}^\Gamma, B_n^\Gamma)$ bimodules. For this we use $w \mapsto wt_{n+1}$ where t_{n+1} is the simple transposition $(n+1, n+2) \in S_{n+2}$. Since t_{n+1} commutes with the subalgebra $B_n^\Gamma \subset B_{n+2}^\Gamma$ this gives a well defined map of $(B_{n+2}^\Gamma, B_n^\Gamma)$ bimodules.

8.4.3. Definition of adj : QP \rightarrow id{-1}. The identity functor on $B_n^\Gamma\text{-gmod}$ is given by tensoring with the (B_n^Γ, B_n^Γ) bimodule B_n^Γ . On the other hand, QP is induced by the bimodule

$$B_{n+1}^\Gamma \otimes_{B_{n+1}^\Gamma} B_{n+1}^\Gamma\{1\}.$$

As a (B_n^Γ, B_n^Γ) bimodule, this is generated by the subalgebra B_1^Γ and the element s_n (so any (B_n^Γ, B_n^Γ) bimodule map is determined by where it sends B_1^Γ and s_n). We define a (B_n^Γ, B_n^Γ) bimodule map

$$B_{n+1}^\Gamma \otimes_{B_{n+1}^\Gamma} B_{n+1}^\Gamma \rightarrow B_n^\Gamma\{-2\}$$

by $s_n \mapsto 0$, $1 \mapsto 0$, $v_1 \mapsto 0$, $v_2 \mapsto 0$, and $\omega = v_1 \wedge v_2 \mapsto 1$ where $\{1, v_1, v_2, v_1 \wedge v_2\}$ is the standard basis of B_1^Γ . This induces a map $QP \rightarrow \text{id}\{-1\}$.

8.4.4. Definition of adj : PQ \rightarrow id{1}. The algebra multiplication

$$B_{n+1}^\Gamma \otimes_{B_n^\Gamma} B_{n+1}^\Gamma \rightarrow B_{n+1}^\Gamma \quad a \otimes b \mapsto ab$$

is a map of $(B_{n+1}^\Gamma, B_{n+1}^\Gamma)$ bimodules and induces the map $\text{adj} : PQ \rightarrow \text{id}\{1\}$.

8.4.5. *Definition of $\text{adj} : \text{id} \rightarrow \text{PQ}\{1\}$.* The functor $\text{PQ}\{1\}$ is induced by the $(B_{n+1}^\Gamma, B_{n+1}^\Gamma)$ bimodule $B_{n+1}^\Gamma \otimes_{B_n^\Gamma} B_{n+1}^\Gamma\{2\}$. Now any $(B_{n+1}^\Gamma, B_{n+1}^\Gamma)$ bimodule map from B_{n+1}^Γ to this bimodule is determined by the image of $1 \in B_{n+1}^\Gamma$. Moreover, an element $b \in B_{n+1}^\Gamma \otimes_{B_n^\Gamma} B_{n+1}^\Gamma$ can be in the image of 1 under such a bimodule map if and only if b is a Casimir element of $B_{n+1}^\Gamma \otimes_{B_n^\Gamma} B_{n+1}^\Gamma$ (i.e. if and only if $yb = (-1)^{|b||y|}by$ for all $y \in B_{n+1}^\Gamma$).

We define the bimodule map $B_{n+1}^\Gamma \rightarrow B_{n+1}^\Gamma \otimes_{B_n^\Gamma} B_{n+1}^\Gamma\{2\}$ by $1 \mapsto b_0$ where

$$b_0 = \sum_{b \in \mathcal{B}} \sum_{i=1}^{n+1} s_i \dots s_n b^\vee \otimes b s_n \dots s_i.$$

where \mathcal{B} is our basis of $B_1^\Gamma \subset B_{n+1}^\Gamma$ and (by convention) $s_i \dots s_n = s_n \dots s_i = 1$ when $i = n+1$ in the summation above. We leave it to the reader to check that b_0 is a Casimir element. This map induces $\text{adj} : \text{id} \rightarrow \text{PQ}\{1\}$.

8.4.6. *Definition of $\text{adj} : \text{id} \rightarrow \text{QP}\{-1\}$.* The functor $\text{QP}\{-1\}$ is induced by the (B_n^Γ, B_n^Γ) bimodule

$$B_{n+1}^\Gamma \otimes_{B_{n+1}^\Gamma} B_{n+1}^\Gamma \cong B_{n+1}^\Gamma.$$

The natural inclusion of B_n^Γ as a subalgebra of B_{n+1}^Γ is a map of (B_n^Γ, B_n^Γ) bimodules and defines $\text{adj} : \text{id} \rightarrow \text{QP}\{-1\}$.

8.5. **The main Theorem.** The following is the analogue of Theorem 2.

Theorem 3. *The functors P and Q together with natural transformations X, T , and adj defined above give a categorical action of \mathcal{H}_Γ on the abelian category $\oplus_n B_n^\Gamma\text{-gmod}$.*

The proof of the above theorem is analogous to the proof of Theorem 2 but easier since none of the functors or natural transformations are derived (in other words, there are no complexes involved and nowhere does one need to take resolutions).

8.6. **Relation to wreath products $\mathbb{k}[\Gamma^n \rtimes S_n]$.** The algebra $\mathbb{k}[\Gamma^n \rtimes S_n]$ embeds as a subalgebra (concentrated in degree zero) of B_n^Γ . This embedding gives rise to induction and restriction functors

$$\text{Ind}_n : \mathbb{k}[\Gamma^n \rtimes S_n]\text{-gmod} \rightarrow B_n^\Gamma\text{-gmod}$$

$$\text{Res}_n : B_n^\Gamma\text{-gmod} \rightarrow \mathbb{k}[\Gamma^n \rtimes S_n]\text{-gmod}$$

between categories of finite dimensional (over \mathbb{k}) graded (super) modules. These functors are (up to shift) left and right adjoint to each other.

Denote by $K_0(\mathbb{k}[\Gamma^n \rtimes S_n])$ and $K_0(B_n^\Gamma)$ the complexified Grothendieck groups of these categories and by $K_P(\mathbb{k}[\Gamma^n \rtimes S_n])$ and $K_P(B_n^\Gamma)$ the subgroups generated by projective modules. Of course, since the characteristic of \mathbb{k} is zero all $\mathbb{k}[\Gamma^n \rtimes S_n]$ modules are projective and $K_0(\mathbb{k}[\Gamma^n \rtimes S_n]) = K_P(\mathbb{k}[\Gamma^n \rtimes S_n])$.

At the same time $\mathbb{k}[\Gamma^n \rtimes S_n]$ is also a quotient of B_n^Γ via the surjection which kills all elements of positive degree. This surjection induces an extension by zero functor

$$\text{ex}_n : \mathbb{k}[\Gamma^n \rtimes S_n]\text{-gmod} \rightarrow B_n^\Gamma\text{-gmod}$$

whose left adjoint is the functor

$$\text{ss}_n : B_n^\Gamma\text{-gmod} \rightarrow \mathbb{k}[\Gamma^n \rtimes S_n]\text{-gmod}$$

which takes a B_n^Γ module to its maximal semisimple quotient considered naturally as a $\mathbb{k}[\Gamma^n \rtimes S_n]$ module. These functors have the following properties:

- the functors Res_n and ex_n induce isomorphisms $K_0(B_n^\Gamma) \cong K_0(\mathbb{k}[\Gamma^n \rtimes S_n])$
- the functors Ind_n and ss_n induce isomorphisms $K_P(B_n^\Gamma) \cong K_P(\mathbb{k}[\Gamma^n \rtimes S_n])$

The functor ss_n does not have finite homological dimension so we restrict to the projective Grothendieck group in the second isomorphism. Therefore, as a corollary to Theorem 3 we obtain the following:

Corollary 2. *The Heisenberg algebra \mathfrak{h}_Γ acts on $\oplus_n K_0(\mathbb{k}[\Gamma^n \rtimes S_n])$ and on $\oplus_n K_P(\mathbb{k}[\Gamma^n \rtimes S_n])$.*

This recovers a theorem of Frenkel-Jing-Wang from [FJW]. However, this action does not appear to come from a categorical action of \mathcal{H}_Γ on the categories $\oplus_n \mathbb{k}[\Gamma^n \rtimes S_n]\text{-gmod}$ (in part because the 2-morphisms in \mathcal{H}_Γ have non-trivial gradings). Indeed the functors constructed in [FJW] give rise to a *non-deformed* Heisenberg algebra action (given by setting $t = 1$ in the definition of \mathfrak{h}_Γ) on $\oplus_n K_0(\mathbb{k}[\Gamma^n \rtimes S_n])$.

In [FJW2] Frenkel-Jing-Wang obtain quantum Heisenberg actions by replacing Γ with $\Gamma \times \mathbb{k}^\times$. This corresponds to considering graded versus ungraded A_n^Γ -modules in this section as well as section 4.

9. OPEN PROBLEMS

We would like to end by discussing what we consider to be interesting unanswered questions.

9.1. Relation to Kac-Moody 2-categories $\mathcal{U}(\mathfrak{g})$. As mentioned in the introduction, there is an obvious analogy between the 2-categories \mathcal{H}_Γ and $\mathcal{U}(\mathfrak{g})$ and their categorical actions. Moreover, when \mathfrak{g} is the affine Lie algebra associated to Γ we expect a direct relationship between \mathcal{H}_Γ and $\mathcal{U}(\mathfrak{g})$.

This expectation is motivated by the existence of two presentations of the affine Lie algebra $U(\mathfrak{g})$, one as an extension of the loop group of the corresponding finite dimensional Lie algebra and one as a Kac-Moody Lie algebra. Similarly, there should be two descriptions of their categorification. The 2-categories $\mathcal{U}(\mathfrak{g})$ from [KL] and [R] categorify the Kac-Moody Lie algebra presentation. A second “loop realization” should come from combining a categorification of the finite dimensional Lie algebra with our Heisenberg category \mathcal{H}_Γ . One would like an equivalence between these 2-categories which lifts the isomorphism between the two different presentations of the affine Lie algebra. We hope to study such a relationship in future work.

9.2. Degenerate affine Hecke algebras. In H^Γ we will also use hollow dots as shorthand for drawing right-twist curls. Subsequently we obtain the following relations.

where $i, j \in I_\Gamma$ are joined by an edge. The hollow dots have an interesting “affine Hecke” type relation with crossings:

These relations are similar to the relations in the degenerate affine Hecke algebra of the symmetric group and its wreath products, which suggests that the endomorphism algebra of P_i^n (or more generally the endomorphism algebra of $P_{i_1}^{n_1} \dots P_{i_k}^{n_k}$) is an interesting algebraic object in its own right. It is perhaps worthwhile to express at least one of these algebras in more standard algebraic notation.

We thus define the graded \mathbb{k} -algebra H_i^n as follows. The generators of H_i^n are elements y_k, z_k for $k = 1, \dots, n$ and t_l for $1 \leq l \leq n - 1$ where

$$\deg(y_k) = \deg(z_k) = 2 \text{ and } \deg(t_l) = 0.$$

The relations are as follows. Firstly, the $\{t_l\}_{l=1}^{n-1}$ generate a subalgebra isomorphic to the group algebra $\mathbb{k}[S_n]$ of the symmetric group, with t_l equal to the simple transposition $(l, l + 1)$. The $\{y_k\}_{k=1}^n$ generate a symmetric algebra $\text{Sym}(y_1, \dots, y_n)$, and $\{z_k\}_{k=1}^n$ generate an exterior algebra $\Lambda(z_1, \dots, z_n)$. The remaining relations are

$$\begin{aligned} y_k z_l &= z_l y_k \text{ for all } k, l \\ t_k y_l &= y_l t_k \text{ for } l \neq k, k + 1, \\ t_k z_l &= z_l t_k \text{ for } l \neq k, k + 1, \\ t_k z_{k+1} &= z_k t_k, \\ t_k z_k &= z_{k+1} t_k, \\ t_k y_{k+1} &= y_k t_k + z_k + z_{k+1}, \\ y_{k+1} t_k &= t_k y_k + z_k + z_{k+1}. \end{aligned}$$

Note that there is a natural map of \mathbb{k} -algebras $H_i^n \rightarrow \text{End}_{\mathcal{H}\Gamma}(P_i^n)$ taking t_k to a crossing between the k and $k + 1$ st strands, y_k to a hollow dot on the k th strand, and z_k to a solid dot on the k th strand.

Conjecture 1. *The natural map of \mathbb{k} -algebras $H_i^n \rightarrow \text{End}_{\mathcal{H}\Gamma}(P_i^n)$ is injective.*

Remark 9.1. In section 8 the functor P^n is induced by the $(B_k^\Gamma, B_{k+n}^\Gamma)$ bimodule $B_{n+k}^\Gamma\{n\}$. Then it is clear from the above definitions of $X(a)$ and T that the map $b \in B_n^\Gamma$ acts on $B_{n+k}^\Gamma\{n\}$ by right multiplication. Subsequently the map $B_n^\Gamma \rightarrow \text{End}_{\mathcal{H}\Gamma}(P^n)$ is injective. When Γ is cyclic (i.e. when \mathcal{H}_Γ and \mathcal{H}^Γ agree), this means that the subalgebra of H_i^n generated by the t 's and z 's injects into $\text{End}_{\mathcal{H}\Gamma}(P_i^n)$.

The more complicated part of the conjecture above involves the hollow dots, which generate a commutative subalgebra of $\text{End}_{\mathcal{H}\Gamma}(P^n)$. Under the analogy between H_i^n and the degenerate affine Hecke algebra, it is natural to consider the image of hollow dots in representations of \mathcal{H}^Γ as ‘‘Jucys-Murphy elements’’. We refer the reader to [K] for a related discussion where the algebra B_n^Γ is replaced by the group algebra $\mathbb{k}[S_n]$ of the symmetric group, in which case the algebra H_i^n is replaced by the degenerate affine Hecke algebra.

The space of 2-morphisms $\text{End}(\text{id})$ from the empty diagram to itself is spanned by closed diagrams. Moreover, since one can slide closed diagrams past vertical lines, one can assume that all closed components appear to the right of all components with boundary. On the other hand, any closed diagram

acts naturally on any space of 2-morphisms in \mathcal{H}^Γ , since closed diagrams can be added to the right of a 2-morphism to produce a new 2-morphism with the same source and target. A more ambitious version of Conjecture 1 is that, up to the action of $\text{End}(\text{id})$, all endomorphisms of P_i^n come from the algebra H_i^n :

Conjecture 2. *The natural map $H_i^n \otimes_{\mathbb{k}} \text{End}_{\mathcal{H}^\Gamma}(\text{id}) \rightarrow \text{End}_{\mathcal{H}^\Gamma}(P_i^n)$ is an isomorphism.*

9.3. The structure of $\text{End}_{\mathcal{H}^\Gamma}(\text{id})$. Conjecture 2 reduces the problem of understanding $\text{End}_{\mathcal{H}^\Gamma}(P_i^n)$ to the problem of understanding $\text{End}_{\mathcal{H}^\Gamma}(\text{id})$. An element of $\text{End}_{\mathcal{H}^\Gamma}(\text{id})$ can be simplified to a linear combination of unions of disjoint, oriented circles containing solid and hollow dots. In fact, with a little manipulation one can also write any counterclockwise oriented circle as a linear combination of products of clockwise oriented circles.

Notice that if you have a circle labeled by $i \in I$ with a solid dot then you can split the dot into two solid dots corresponding to maps $P_i \rightarrow P_j \langle 1 \rangle \rightarrow P_i \langle 2 \rangle$ where $i, j \in I$ are joined by an edge in the Dynkin diagram. Moving one of the dots around the other side and joining back the two dots gives a circle labeled j with a solid dot. Thus it is clear that the label on a circle containing a solid dot is irrelevant.

For $i \in I$ and $k \in \mathbb{N}$ let

- c_k^i be a clockwise circle labeled i containing exactly k hollow dots, and
- c_k denote a clockwise circle containing one solid dot and k hollow dots (the labeling of the circle c_k is not important by the observation above).

Notice that $\deg(c_k^i) = 2k + 2$ and $\deg(c_k) = 2k + 4$.

Conjecture 3. *$\text{End}_{\mathcal{H}^\Gamma}(\text{id})$ is isomorphic to the symmetric algebra freely generated by $\{c_k^i\}_{k \geq 0, i \in I}$ and $\{c_k\}_{k \geq 0}$.*

9.4. Hochschild cohomology of Hilbert schemes. The endomorphism algebras $\text{End}_{\mathcal{H}^\Gamma}(\text{id})$ and $\text{End}_{\mathcal{H}^\Gamma}(P_i^n)$ are analogous in some respects to both the degenerate affine Hecke algebra of the symmetric group and also to the quiver Hecke algebras of Khovanov-Lauda and Rouquier [KL, R]. In particular, ‘‘cyclotomic quotients’’ of these endomorphism algebras should have an interesting structure. These quotient algebras are given by killing any diagram containing a region labeled by an integer less than a fixed integer k .

For example, our action of \mathcal{H}^Γ on $\oplus_n \text{DCoh}(\widehat{\text{Hilb}^n(\mathbb{C}^2/\Gamma)})$ gives a map

$$\text{End}_{\mathcal{H}^\Gamma}(\text{id}) \rightarrow HH^*(\widehat{\text{Hilb}^n(\mathbb{C}^2/\Gamma)})$$

for each n where HH^* denotes the Hochschild cohomology. There should be some relation between ‘‘cyclotomic quotients’’ on the left side and the Hochschild cohomology on the right side.

APPENDIX A. THE CASE $\Gamma = \mathbb{Z}_2$

The case $\Gamma = \mathbb{Z}_2$ differs slightly from other non-trivial $\Gamma \subset SL_2(\mathbb{C})$ and the main definitions in the body of the paper need to be modified slightly. We collect the appropriate definitions for $\Gamma = \mathbb{Z}_2$ in this section. Having made these definitions all of the results and proofs in the body of the paper carry over to $\Gamma = \mathbb{Z}_2$ without difficulty.

The vertex set $I_{\mathbb{Z}_2} = \{0, 1\}$ consists of the two distinct isomorphism classes of representations of \mathbb{Z}_2 , the trivial representation and the sign representation. The quantum Cartan matrix $C_{\mathbb{Z}_2}$ is the matrix with entries $\langle i, j \rangle$ indexed by $i, j \in I_{\mathbb{Z}_2}$ given by

$$\langle i, j \rangle = \begin{cases} t + t^{-1} & \text{if } i = j \\ -2 & \text{if } i \neq j. \end{cases}$$

The Heisenberg algebra $\mathfrak{h}_{\mathbb{Z}_2}$ is the unital infinite dimensional $\mathbb{k}[t, t^{-1}]$ algebra with generators $p_i^{(n)}, q_i^{(n)}$ for $i \in I_{\mathbb{Z}_2}$ and integers $n \geq 0$, with relations

$$(31) \quad p_i^{(n)} p_j^{(m)} = p_j^{(m)} p_i^{(n)} \text{ for all } i, j \in I_{\mathbb{Z}_2},$$

$$(32) \quad q_i^{(n)} q_j^{(m)} = q_j^{(m)} q_i^{(n)} \text{ for all } i, j \in I_{\mathbb{Z}_2},$$

$$(33) \quad q_i^{(n)} p_i^{(m)} = \sum_{k \geq 0} [k+1] p_i^{(m-k)} q_i^{(n-k)} \text{ for all } i \in I_{\mathbb{Z}_2},$$

$$(34) \quad q_i^{(n)} p_j^{(m)} = \sum_{k \geq 0} (k+1) p_j^{(m-k)} q_i^{(n-k)} \text{ for all } i \neq j \in I_{\mathbb{Z}_2}.$$

Note that the coefficients in equation (33) above involve the quantum integers $[k+1]$ while in equation (34) they involve ordinary integers $(k+1)$.

The definition of the 2-category $\mathcal{H}'_{\mathbb{Z}_2}$ is the same as before (and $\mathcal{H}_{\mathbb{Z}_2}$ is still defined as the Karoubi envelope of $\mathcal{H}'_{\mathbb{Z}_2}$).

On the other hand, $\mathcal{H}^{\mathbb{Z}_2}$ is slightly different. We fix an orientation ϵ of the Dynkin diagram. Since there are two edges connecting the two vertices i and j we describe the orientation ϵ by two functions $\epsilon_{ij}(0)$ and $\epsilon_{ij}(1)$. More precisely, $\epsilon_{ij}(0) = \pm 1$ depending on whether the first edge is oriented from i to j or from j to i . Similarly, $\epsilon_{ij}(1)$ describes the orientation of the second edge.

As in the case $\Gamma \neq \mathbb{Z}_2$ the objects of $\mathcal{H}^{\mathbb{Z}_2}$ are indexed by the integers \mathbb{Z} while the 1-morphisms are generated by P_i and Q_i ($i \in I_{\mathbb{Z}_2}$).

The space of 2-morphisms is the \mathbb{k} -algebra generated by suitable planar diagrams modulo local relations. As before, the diagrams consist of oriented compact one-manifolds immersed into the plane strip $\mathbb{R} \times [0, 1]$ (possibly with crossings) modulo isotopies fixing the boundary.

Each such strand is labeled by some $i \in I_{\mathbb{Z}_2}$. It can carry a solid dot as before which represents a map $X : P_i \rightarrow P_i \langle 2 \rangle$. These ii dots move freely on strands and through crossings just as in the case $\Gamma \neq \mathbb{Z}_2$.

The main difference is that the strands now also carry a hollow rectangle (see below). More precisely, corresponding to each of the two edges in the Dynkin diagram connecting vertices i and j there is a 2-morphism $X : P_i \rightarrow P_j \langle 1 \rangle$ (one denoted by the solid dot and the other by the hollow rectangle).

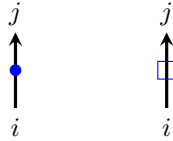

These ij dots and rectangles are also allowed to move freely along the one-manifold along cups and caps and through crossings. Dots or rectangles on distinct strands anticommute when they move past each other relative to the vertical. The relations which govern compositions are as follows:

$$(35) \quad \begin{array}{c} i \\ \uparrow \\ j \bullet \\ | \\ i \end{array} = \epsilon_{ij}(0) \begin{array}{c} i \\ \uparrow \\ \bullet \\ | \\ i \end{array} \quad \begin{array}{c} i \\ \uparrow \\ j \square \\ | \\ i \end{array} = \epsilon_{ij}(1) \begin{array}{c} i \\ \uparrow \\ \bullet \\ | \\ i \end{array} \quad \begin{array}{c} i \\ \uparrow \\ j \square \\ | \\ i \end{array} = \begin{array}{c} i \\ \uparrow \\ j \bullet \\ | \\ i \end{array} = 0.$$

Also, the composition of an ii dot with any other dot or rectangle is zero.

Next, we have the same relations (24) and (25) as well as (27). The only more interesting relation is (26) which is replaced by

$$(36) \quad \begin{array}{c} \begin{array}{c} \nearrow \\ \searrow \\ \nearrow \\ \searrow \\ i \quad j \end{array} = \begin{array}{c} \downarrow \\ i \quad j \end{array} + \begin{array}{c} \uparrow \\ i \quad j \end{array} - \epsilon_{ij}(0) \begin{array}{c} i \quad j \\ \cup \quad \cap \\ \bullet \quad \bullet \\ i \quad j \end{array} - \epsilon_{ij}(1) \begin{array}{c} i \quad j \\ \cup \quad \cap \\ \square \quad \square \\ i \quad j \end{array} \end{array}$$

Finally, we assign a \mathbb{Z} -grading on the space of planar diagrams like before. In particular, we define the degree of both an ij dot and an ij rectangle to be one when $i \neq j$ and the degree of an ii dot to be two. Equipped with these assignments all the graphical relations are graded, providing a \mathbb{Z} -grading on $\mathcal{H}^{\mathbb{Z}_2}$. We then define $\mathcal{H}^{\mathbb{Z}_2}$ to be the Karoubi envelope of $\mathcal{H}^{\mathbb{Z}_2}$.

REFERENCES

- [BKR] T. Bridgeland, A. King, and M. Reid, The McKay correspondence as an equivalence of derived categories, *J. Amer. Math. Soc.* **14**, (2001), 535–554; [math.AG/9908027](#).
- [CG] N. Chriss and V. Ginzburg, *Representation theory and complex geometry*, Birkäuser, 1997.
- [CKL] S. Cautis, J. Kamnitzer and A. Licata, Coherent sheaves on quiver varieties and categorification, (in preparation).
- [FJW] I. Frenkel, N. Jing, and W. Wang, Vertex Representations via finite groups and the McKay correspondence, *Int. Math. Res. Not.* (2000), no. 4.
- [FJW2] I. Frenkel, N. Jing, and W. Wang, Quantum vertex representations via finite groups and the McKay correspondence, *Commun. Math. Phys.* **211** (2000).
- [FT] B. Feigin, A. Tsymbaliuk, Heisenberg algebra in the equivariant K-theory of Hilbert schemes via shuffle algebra; [arXiv:0904.1679](#).
- [FKM] I. Frenkel, M. Khovanov and A. Malkin, unpublished notes, circa 2003.
- [G] I. Grojnowski, Instantons and affine Lie algebras I: The Hilbert scheme and vertex operators, *Math. Res. Lett.* **3** (1996), 275–291.
- [H] M. Haiman, Hilbert schemes, polygraphs and the Macdonald positivity conjecture; *J. Amer. Math. Soc.* **14**, no. 4, 941–1006.
- [KL] M. Khovanov and A. Lauda, A diagrammatic approach to categorification of quantum groups I, II, and III; [math.QA/0803.4121](#), [math.QA/0804.2080](#), and [math.QA/0807.3250](#).
- [K] M. Khovanov, Heisenberg algebra and a graphical calculus; [arXiv:1009.3295](#)
- [N1] H. Nakajima, Heisenberg algebra and Hilbert schemes of points on projective surfaces; *Ann. of Math. (2)* **145** (1997), no.2, 379–388.
- [N2] H. Nakajima, Quiver varieties and Kac-Moody algebras. *Duke Math. J.* **91** (1998), no. 3, 515–560.
- [N3] H. Nakajima, Quiver varieties and finite-dimensional representations of quantum affine algebras. *J. Amer. Math. Soc.* **14** (2001), no. 1, 145–238.
- [R] R. Rouquier, 2-Kac-Moody algebras; [arXiv:0812.5023](#).
- [RS] A. Ram and A. Shepler, Classification of graded Hecke algebras for complex reflection groups, *Comment. Math. Helv.* **78** (2003).
- [SV] O. Schiffmann and E. Vasserot, The elliptic Hall algebra and the K-Theory of the Hilbert scheme of \mathbb{A}^2 ; [arXiv:0905.2555](#).
- [W] J. Wan, Wreath Hecke algebras and centralizer construction for wreath products, *Journal of Algebra*, **323**, (2010).
- [WW] J. Wan and W. Wang, Modular representations and branching rules for wreath Hecke algebras, *Int. Math. Res. Not.* (2008) Art. ID rnn128.

E-mail address: scautis@math.columbia.edu

DEPARTMENT OF MATHEMATICS, COLUMBIA UNIVERSITY, NEW YORK, NY

E-mail address: amlicata@math.stanford.edu

DEPARTMENT OF MATHEMATICS, STANFORD UNIVERSITY, STANFORD, CA