

Integrated application of cluster and multicriterion analysis for ranking water resources planning strategies: a case study in Spain

K. Srinivasa Raju and Lucien Duckstein

ABSTRACT

Integrated application of cluster analysis and Multicriterion Decision-Making (MCDM) is employed for the case study of the Flumen Monegros irrigation area in the Huesca province of Spain. Economic, environmental and social criteria are used to rank alternative strategies. Alternative strategies are formulated by mixing factors such as irrigation systems, water pricing, water allocation, crop distribution, fertiliser use and subsidies received. Cluster analysis is employed to reduce the large size payoff matrix to a manageable subset for further use of the MCDM technique. ELECTRE-3, an MCDM technique of outranking nature, is employed to rank the alternative strategies. The Kendall rank correlation coefficient is employed here to analyse the correlation between the ranking patterns obtained from various scenarios. Results indicate that three representative strategies are to be preferred based on this analysis.

Key words | cluster analysis, ELECTRE-3, multicriterion decision making, Spain, water resources planning

K. Srinivasa Raju (corresponding author)
Department of Civil Engineering,
Birla Institute of Technology and Science,
Pilani 333 031,
Rajasthan,
India
E-mail: ksraju@bits-pilani.ac.in

Lucien Duckstein
GRESE,
Ecole Nationale Du Genie Rural,
Des Eaux Et Des Forets,
19 Avenue Du Maine 75732 Paris Cedex 15,
France
E-mail: Duckstein@Engref.fr

INTRODUCTION

The need for efficient integrated water management which would take into account all aspects of water, including quality, quantity, socio-economic activities, protection of the environment and alleviation of the adverse impacts of floods and droughts is keenly felt. This is essential to manage water resources in a more sustainable way in view of the ever-growing demands and dwindling supplies (Loucks *et al.* 1981). Vadas (1999) classified the following aspects to be affecting water resources planning: (1) poorly quantified environmental impacts, (2) stakeholder involvement, (3) economic development, (4) lack of a holistic management approach, (5) land degradation, (6) hydrology, (7) urbanisation and industrialisation and (8) water quality. Tuan & Thanh (1999) discussed some typical measures such as improving the knowledge of the concerned people about water conservation, environmental protection and the development of a strategy to redistribute water resources to increase efficiency. In the

present study an effort is made to establish a framework to evolve a sustainable water policy and select realistic plans based on the available knowledge of economic, environmental and sociological aspects for implementation in a multicriterion context (Szidarovszky *et al.* 1986; Pomerol & Romero 2000) for the case study of Spain. The present study is an improvement over previous works of the authors (see Raju *et al.* 2000) incorporating newer methodologies such as (1) the introduction of cluster analysis to partition the set of generated alternative strategies into groups of similar characteristics, (2) the application of ELECTRE-3, a Multicriterion Decision-Making (MCDM) technique for outranking nature with a detailed description and extensive sensitivity analysis and (3) the utilisation of the Kendall rank correlation coefficient to analyse the correlation between the ranking patterns. The study is divided into a description of the case study and problem formulation, actual operation

of the suggested procedures, the results and a discussion followed by conclusions.

CASE STUDY AND PROBLEM FORMULATION

Description of case study

The present study analyses the Flumen Monegros irrigation area in the Huesca province of Spain which comprises the two administrative districts of Huesca and Monegros. The total area of both districts is 85,500 ha (Breuil *et al.* 2000). The climate is semi-arid with insufficient rainfall. Irrigation is therefore essential for agricultural production. The main source of irrigation water is the Sotonera dam with a capacity of 187 Mm³ supplemented by the Cinca river system. About 13,200 ha of the area is prone to salinity and alkalinity. Irrigation efficiency ranges from 40–80%. More information on the irrigation management aspects in Spain is available from Country Profile-Spain (2000).

Identification of criteria

The factors identified after discussions, supported by the literature (Breuil *et al.* 2000), are classified into three groups:

- Economic factors: initial cost (often borne by the state) (C1), maintenance cost (C2), profitability of crops (C3), extent of subsidies (C4).
- Environmental (sustainability based) factors: volume of water used for irrigation (C5), quality of water after irrigation (C6), irrigation efficiency (C7), resistance to floods or droughts (C8).
- Social factors: employment of population (C9), land area which is not cultivated (C10).

A scale of 0–100 is chosen to rate the criteria (100 for very highly important, 80 for very important, 60 for important, 40 for average, 20 for satisfactory and 0 for unsatisfactory). However, the option is given to the decision-maker to choose any intermediate values to minimise subjectivity in estimating the weights. The resultant weights are (40,

40, 80, 40) for economic factors, (40, 25, 25,10) for environmental factors and (50,50) for social factors. Normalised weights are (0.1, 0.1, 0.2, 0.1) for economic factors, (0.1, 0.06, 0.06, 0.03) for environmental factors and (0.125, 0.125) for social factors.

Formulation of alternative strategies

The following six elements are found relevant to the present problem of defining a set of alternative strategies which could affect the planning scenario (Breuil *et al.* 2000): irrigation system (A1: surface, A2: sprinkler, A3: drip), price of water (B1: do nothing, B2: raise prices to 10 pta/m³, B3: raise prices to 20 pta/m³), water allocation (C1: do nothing, C2: market of quotas, C3: assigned quotas), distribution of crops (D1: do nothing, D2: wheat/barley, D3: fruit and vegetables, D4: sugar beet), fertilisers (E1: do nothing, E2: use of city sludge, E3: use of green fertilisers), existence of subsidies (F1: yes, F2: no). 'Do nothing' indicates 'without change in the existing policy'.

Every subdivision of the elements is evaluated by a team of experts who are familiar with the planning area by considering economic, environmental and social criteria. Descriptive indicators are used in the initial evaluation. Table 1 presents a linearly quantified matrix (actions versus direct consequences on different system criteria). The notations in Table 1 is as follows: A represents very high/very cheap; B, good/cheap; C, average; D, poor/low; E, very poor/very low; X, no (negligible) effect on the planning problem. These are then converted into numerical values (50, 40, 30, 20, 10 and 0, respectively) for further use.

Starting from the set of six elements (irrigation system, water pricing, water allocation, crop distribution, fertilisers and subsidies) and their subdivisions, all these factors are combined to create alternative strategies. From the eighteen subdivisions of the six major elements (shown in Table 1), the total number of possible combinations comes to $3 \times 3 \times 3 \times 4 \times 3 \times 2 = 648$ different strategies. Out of the 648 alternative strategies, 487 are discarded, leaving 161 with the approval of experts and the decision-maker as the others are found to be unacceptable or even irrational (Raju *et al.* 2000).

Table 1 | Quantitative matrix: actions versus direct consequences on different system criteria

	A1	A2	A3	B1	B2	B3	C1	C2	C3	D1	D2	D3	D4	E1	E2	E3	F1	F2
C1	A	C	E	X	X	X	X	X	X	A	C	E	C	C	A	D	X	X
C2	B	C	E	B	E	E	X	X	X	D	C	E	D	X	X	X	X	X
C3	C	C	B	A	C	E	X	X	X	B	B	A	A	B	B	B	X	X
C4	X	X	X	X	X	X	X	X	X	B	A	E	E	E	B	C	B	E
C5	E	C	A	D	D	B	D	B	B	D	B	C	A	X	X	X	X	X
C6	E	C	B	X	X	X	X	X	X	D	D	E	A	D	E	B	X	X
C7	D	C	A	X	X	X	X	X	X	D	C	A	X	X	X	X	X	X
C8	E	A	A	X	X	X	X	X	X	D	B	D	C	D	E	A	X	X
C9	A	C	D	C	D	E	C	E	D	D	D	B	D	C	B	C	B	E
C10	X	X	X	C	D	E	C	E	D	C	D	E	D	C	D	B	B	E

It is felt that the size of the payoff matrix with 161 alternative strategies and 10 criteria is still too large for evaluation by the MCDM technique. Rogers *et al.* (2000) suggested that, if too many options are available at the start of the process and if some of the chosen options are so closely related that they are variants of one another, these could just as well be represented by one option for the purpose of decision-making. In this study cluster analysis is employed as a grouping procedure, prior to application of a multicriterion analysis as explained below.

Cluster analysis

The number of alternative strategies (161) is still large. It is difficult to reduce it further manually as the difference between two given strategies is too imperceptible to a manual procedure, compared to a machine. In this regard the technique of cluster analysis is used to reduce the number of strategies to a more manageable subset (Morse 1980). Cluster analysis offers several advantages over manual grouping: (1) the clustering programme can apply

a specified objective function consistently to form the groups, avoiding a possible inconsistency due to human error and (2) the clustering algorithm can form the groups in a small fraction of the time taken for manual grouping, particularly if many criteria are associated with each strategy (Jain & Dubes 1988).

Cluster analysis partitions an alternative strategy set of size N into K clusters (groups) of relatively homogeneous strategies. In clustering, strategies in a cluster are more similar to each other than those of the other clusters. A K -means clustering algorithm (Jain & Dubes 1988) is used to minimise within-cluster sums of squares of differences (errors) based on the initial partitions to obtain the final partitions. In this technique, alternative strategies are grouped so that each alternative strategy is assigned to one of the fixed number K of groups. The sum of the squared differences of each criterion from its assigned cluster mean is used as the criterion for the assignment. Alternative strategies are transferred from one cluster to another, so that the within-cluster sum of the squared differences (error) decreases. In a pass through the entire data set, if no transfer occurs, the

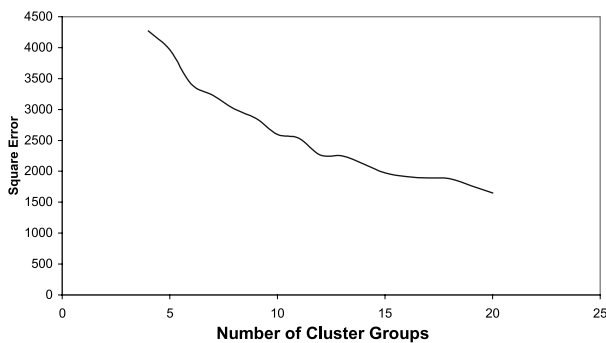

Figure 1 | Number of cluster groups versus squared error values.

algorithm stops. The total square error value E_K for cluster group K is given by

$$E_K = \sum_{k=1}^K e_k^2 \quad (1)$$

where e_k = the error value for each cluster group k .

Several runs are made by K -means algorithm for each clustering, with different numbers in the initial partitions, until no decrease in squared error value is observed for that clustering. Figure 1 presents squared error values for clustering having partitions varying from 4 to 20. Clustering containing 1–3 partitions is not done since this will narrow the band of results abnormally. It is observed that the values of squared error are decreasing with the increase in the number of clusters. The optimum number of cluster groups is taken as 12 after extensive discussions with the decision-maker. Table 2 presents the results of cluster analysis. The number of alternative strategies in the 12 groups are 12, 8, 13, 12, 13, 14, 18, 17, 10, 13, 9 and 22, respectively. Representative strategies are chosen from each group based on the minimum squared error values. For this purpose the squared error values between group mean and strategy values for each criterion in that group are calculated. The summation of these squared error values for all criteria gives the total squared error value corresponding to each strategy in that group. The strategy that gives the minimum total squared error value is chosen as the representative strategy for that group. The representative strategies are 114, 62, 113, 4, 45, 58, 76, 32, 36, 34,

14 and 150 and these are represented as G1–G12. Table 3 presents the representative strategies showing their criteria with reference to the assigned factors, which is self-explanatory. For example, in Table 3 G1 indicates a combination of sprinkler irrigation system with a water pricing of 20 pta/m³ with the introduction of assigned quotas. Wheat/barley is the growing crop with existing fertiliser policy and with subsidies cut off. Table 4 presents the payoff matrix for the 12 representative strategies versus the 10 criteria. The best of the strategies are selected using ELECTRE-3 as explained below.

Description of ELECTRE-3

In the present study ELECTRE-3 (ELimination Et Choix Traduisant la REalite), a MCDM technique of outranking nature, is applied to the present water resources planning problem. ELECTRE-3 is preferred due to its ability to incorporate the fuzzy (imprecise and uncertain) nature of decision-making by using thresholds of indifference (q_j), preference (p_j) and veto thresholds (v_j) and these are in the order $v_j > p_j > q_j$. Here q_j is the indifference threshold that represents the largest difference that is considered negligible by the decision-maker when comparing two alternative strategies of that criterion, p_j is the preference threshold that represents the smallest difference that justifies a strict preference for one of the two alternative strategies and v_j is the veto threshold that represents a difference so large that it will prohibit an alternative strategy from outranking the other, even if the former is much better for the other criteria. These thresholds produce outranking relations while making allowances for imprecision/uncertainty in the data (Roy *et al.* 1992; Duckstein *et al.* 1994; Buchanan *et al.* 1999; Rogers & Bruen 2000). In this technique the concordance index, discordance index and credibility index are formulated as explained below (Hokkanen & Salminen 1997; Rogers & Bruen 2000). The concordance index $C(a,b)$ is computed for each pair (a,b) of alternative strategies. This is based on the comparison of the performances of alternative strategies a and b over all the criteria. It varies from 0 to 1, with the value 0 indicating that alternative strategy a is worse than alternative strategy b for all criteria and the value of 1

Table 2 | Results of K-means cluster analysis

Group no.	Alternative strategies in the group	Total squared error from group mean	Representative alternative strategy
1	98, 99, 100, 106, 107, 108, 114, 115, 116, 148, 153, 158	122.595	114 (G1)
2	61, 62, 93, 94, 125, 126, 145, 146	102.606	62 (G2)
3	103, 105, 111, 112, 113, 119, 120, 121, 147, 152, 154, 157, 159	182.210	113 (G3)
4	1, 2, 3, 4, 15, 16, 39, 40, 41, 42, 43, 44	145.264	4 (G4)
5	5, 6, 7, 8, 17, 18, 19, 20, 45, 46, 47, 48, 49	248.552	45 (G5)
6	58, 59, 60, 64, 65, 92, 96, 97, 122, 123, 124, 142, 143, 144	254.239	58 (G6)
7	66, 68, 74, 75, 76, 82, 83, 84, 127, 128, 129, 132, 133, 134, 137, 138, 139, 149	230.299	76 (G7)
8	25, 26, 27, 31, 32, 37, 38, 71, 72, 73, 79, 80, 81, 87, 88, 89, 104	204.195	32 (G8)
9	11, 23, 24, 29, 30, 35, 36, 53, 69, 70	110.151	36 (G9)
10	9, 10, 21, 22, 28, 33, 34, 50, 51, 52, 67, 90, 91	199.098	34 (G10)
11	12, 13, 14, 54, 55, 56, 57, 63, 95	142.110	14 (G11)
12	77, 78, 85, 86, 101, 102, 109, 110, 117, 118, 130, 131, 135, 136, 140, 141, 150, 151, 155, 156, 160, 161	321.640	150 (G12)

indicating that there is no criterion for which b is better than a . The concordance index $C(a,b)$ is computed for each pair of alternative strategies a and b (if $f_j(a) \geq f_j(b)$) as

$$C(a,b) = \frac{\sum_{j=1}^J w_j c_j(a,b)}{\sum_{j=1}^J w_j} \tag{2}$$

where $f_j(a)$ and $f_j(b)$ are ratings of the two alternative strategies a and b for criterion j , $c_j(a,b)$ = outranking degree of alternative strategies a and b under criterion j , w_j = weight of criterion j and J = the number of criteria.

One sets the relation

$$c_j(a,b) = 0 \text{ if } (f_j(b) - f_j(a)) > p_j \tag{3}$$

$$c_j(a,b) = 1 \text{ if } (f_j(b) - f_j(a)) \leq q_j \tag{4}$$

On the other hand, if the relationship is between the above two extreme values of $c_j(a,b)$, the concordance index can be calculated as a linear variation between extremes as follows:

$$c_j(a,b) = \frac{f_j(a) - f_j(b) + p_j}{p_j - q_j} \text{ if } q_j < (f_j(b) - f_j(a)) \leq p_j. \tag{5}$$

The veto threshold for each criterion is to be assigned to allow discordance to be introduced into the outranking

Table 3 | Representative strategies and their criteria

Representative strategy	Irrigation system	Water pricing (pta/m ³)	Water allocation	Crop type	Fertiliser	Subsidies
G1	Sprinkler	20	Assigned quotas	Wheat/barley	Do nothing	No
G2	Sprinkler	10	Do nothing	Fruit/vegetables	Green fertiliser	Yes
G3	Sprinkler	20	Market quotas	Sugar beet	Green fertiliser	No
G4	Surface	Do nothing	Do nothing	Wheat/barley	Green fertiliser	Yes
G5	Sprinkler	Do nothing	Do nothing	Fruit/vegetables	Do nothing	Yes
G6	Sprinkler	10	Do nothing	Wheat/barley	Do nothing	Yes
G7	Sprinkler	10	Market quotas	Wheat/barley	Green fertiliser	No
G8	Surface	10	Market quotas	Sugar beet	Green fertiliser	No
G9	Surface	10	Assigned quotas	Fruit/vegetables	Green fertiliser	No
G10	Surface	10	Assigned quotas	Wheat/barley	Green fertiliser	No
G11	Surface	Do nothing	Do nothing	Sugar beet	Green fertiliser	No
G12	Drip	20	Do nothing	Fruit/vegetables	Do nothing	No

*'Do nothing' indicates 'without change in the existing policy'.

relation. The essence of discordance is that any outranking of b by a indicated by the concordance index can be over-ruled if there is any criterion for which option b outperforms option a by at least the veto threshold, i.e.

$$f_j(b) - f_j(a) \geq v_j \quad (6)$$

In some scenarios, if option a is better than option b , there may be some criteria for which option a is so much worse than option b that it moderates any overall preference for option a and is reflected by the concept of discordance index. Discordance index $d_j(a,b)$ is computed for each pair of alternative strategies a and b for specific criterion j (if $f_j(a) \geq f_j(b)$) as

$$d_j(a,b) = 0 \text{ if } (f_j(b) - f_j(a)) \leq p_j \quad (7)$$

$$d_j(a,b) = 1 \text{ if } (f_j(b) - f_j(a)) > v_j \quad (8)$$

On the other hand, if the relationship is between the above two extreme values of $d_j(a,b)$, the discordance index can be represented as a linear variation between these extremes as

$$d_j(a,b) = \frac{f_j(b) - f_j(a) - p_j}{v_j - p_j} \text{ if } p_j < (f_j(b) - f_j(a)) \leq v_j. \quad (9)$$

For each pair of alternative strategies (a,b) , there exists a concordance and a discordance measure. The final step is to combine these two measures to produce a measure of the degree of outranking, i.e. a credibility matrix which assesses the strength of the assertion that ' a is at least as good as b '. The degree of fuzzy outranking/credibility index $S(a,b)$ is defined as

$$S(a,b) = C(a,b) \text{ if } d_j(a,b) \leq C(a,b), \forall j \in J. \quad (10)$$

Table 4 | Payoff matrix of each representative strategy versus each criterion

Criterion Representative strategy	C1	C2	C3	C4	C5	C6	C7	C8	C9	C10
G1	90	70	130	70	150	70	60	110	120	90
G2	60	50	200	80	100	80	80	120	190	140
G3	80	60	140	50	160	120	30	130	110	90
G4	100	110	210	120	90	70	50	100	200	160
G5	70	80	220	60	100	60	80	90	200	140
G6	90	70	190	100	110	70	60	110	170	140
G7	80	70	150	90	130	90	60	140	120	100
G8	100	70	160	50	120	100	20	90	140	100
G9	80	60	160	50	100	60	70	80	170	100
G10	100	80	150	90	110	70	50	100	150	110
G11	100	100	180	50	100	100	20	90	170	130
G12	50	30	150	30	140	70	100	90	140	90

Otherwise

$$S(a,b) = C(a,b) \prod_{j \in J(a,b)} \frac{(1 - d_j(a,b))}{(1 - C(a,b))} \quad (11)$$

where $J(a,b)$ is the set of criteria for which $d_j(a,b) > C(a,b)$.

The degree of outranking is thus equal to the concordance index, where no criterion is discordant, and is lowered as the level of discordance increases beyond a threshold value. The credibility index for each pair of alternative strategies are then introduced into a distillation procedure to derive the overall ranking of the strategies (Rogers & Bruen 2000) as explained below.

1. Construct a complete preorder Z_1 through a descending distillation procedure, i.e. preorder is obtained in a descending manner, selecting the best rated options initially and finishing with the assignment of the worst.

2. Construct a complete preorder Z_2 through an ascending distillation procedure, i.e. preorder is obtained in an ascending manner, first selecting the worst rated options and then finishing with the assignment of the best.
3. Construct the partial preorder $Z = Z_1 \cap Z_2$ as the final distillation, i.e. results of the two preorders are combined to yield a final ranking consistent with both.

More detailed information on this distillation procedure is available in Rogers & Bruen (2000) and Rogers *et al.* (2000).

RESULTS AND DISCUSSION

The ELECTRE-3 algorithm has been applied using the Decision Support System developed by LAMSADE

Table 5 | Concordance index of ELECTRE-3 (distillation coefficients $-0.15, 0.3$)

	G1	G2	G3	G4	G5	G6	G7	G8	G9	G10	G11	G12
G1	1.00	0.30	0.61	0.25	0.39	0.45	0.49	0.39	0.49	0.25	0.29	0.62
G2	0.70	1.00	0.61	0.25	0.47	0.60	0.51	0.64	0.80	0.60	0.74	0.84
G3	0.51	0.39	1.00	0.19	0.29	0.19	0.26	0.35	0.49	0.19	0.35	0.62
G4	0.81	0.75	0.81	1.00	0.64	0.81	0.75	0.84	0.84	0.90	0.84	0.84
G5	0.61	0.81	0.71	0.49	1.00	0.61	0.61	0.74	0.90	0.61	0.74	0.78
G6	0.90	0.52	0.81	0.25	0.51	1.00	0.81	0.74	0.94	0.80	0.74	0.84
G7	0.80	0.49	0.84	0.25	0.39	0.35	1.00	0.51	0.62	0.55	0.29	0.71
G8	0.71	0.36	0.75	0.26	0.29	0.36	0.71	1.00	0.81	0.46	0.45	0.84
G9	0.51	0.30	0.81	0.16	0.26	0.19	0.61	0.61	1.00	0.38	0.38	0.75
G10	0.81	0.40	0.81	0.35	0.49	0.36	0.75	0.64	0.62	1.00	0.39	0.84
G11	0.71	0.36	0.75	0.26	0.39	0.38	0.71	0.90	0.94	0.71	1.00	0.84
G12	0.57	0.16	0.51	0.22	0.25	0.22	0.49	0.31	0.25	0.42	0.19	1.00

(Vallée & Zielniewicz 1994). Threshold values of indifference, preference and veto thresholds are fixed based on the minimum and maximum values of each criterion (as observed from Table 4) and from a detailed discussion with the decision-maker who is having considerable experience in the field of MCDM. Based on the above methodology, indifference, preference and veto thresholds are fixed as 0, 10 and 15 for all the criteria (Rogers & Bruen 2000; Rogers *et al.* 2000). However, extensive sensitivity analysis is performed to assess the robustness in the ranking pattern to various thresholds and distillation coefficients. Weights proposed by the decision-maker are used in the present study. Results are analysed with and without veto thresholds to observe their effect on the ranking pattern.

Table 5 presents concordance index values, where it is observed that diagonal values are one when the comparison is between the same alternative strategy. In this case (neglecting veto thresholds), the credibility index is equal

to the concordance index as evident from Equation (10). The distillation coefficients α and β employed are -0.15 and 0.3 , respectively. Figure 2 presents ranking patterns corresponding to the descending, ascending and final distillation procedures. The final ranking of alternative strategy resulting from the intersection of 2 preorders is also given in Table 6. It can be seen that alternative strategy G4 is best followed by alternative strategies G5, G6 being tied at rank 2 whereas alternative strategies G10 and G11 are tied at rank 3. Table 7 presents credibility index values when veto thresholds are considered. In this case the concordance index is the same as presented in Table 5 whereas the credibility index is not the same as the concordance index as is evident from Equation (11) due to the introduction of the discordance index. The same values of distillation coefficients are employed as in the above case, namely $\alpha = -0.15$ and $\beta = 0.3$. It is observed from Table 6 that alternative strategy G6 is best, followed by alternative strategy G5 at rank 2.

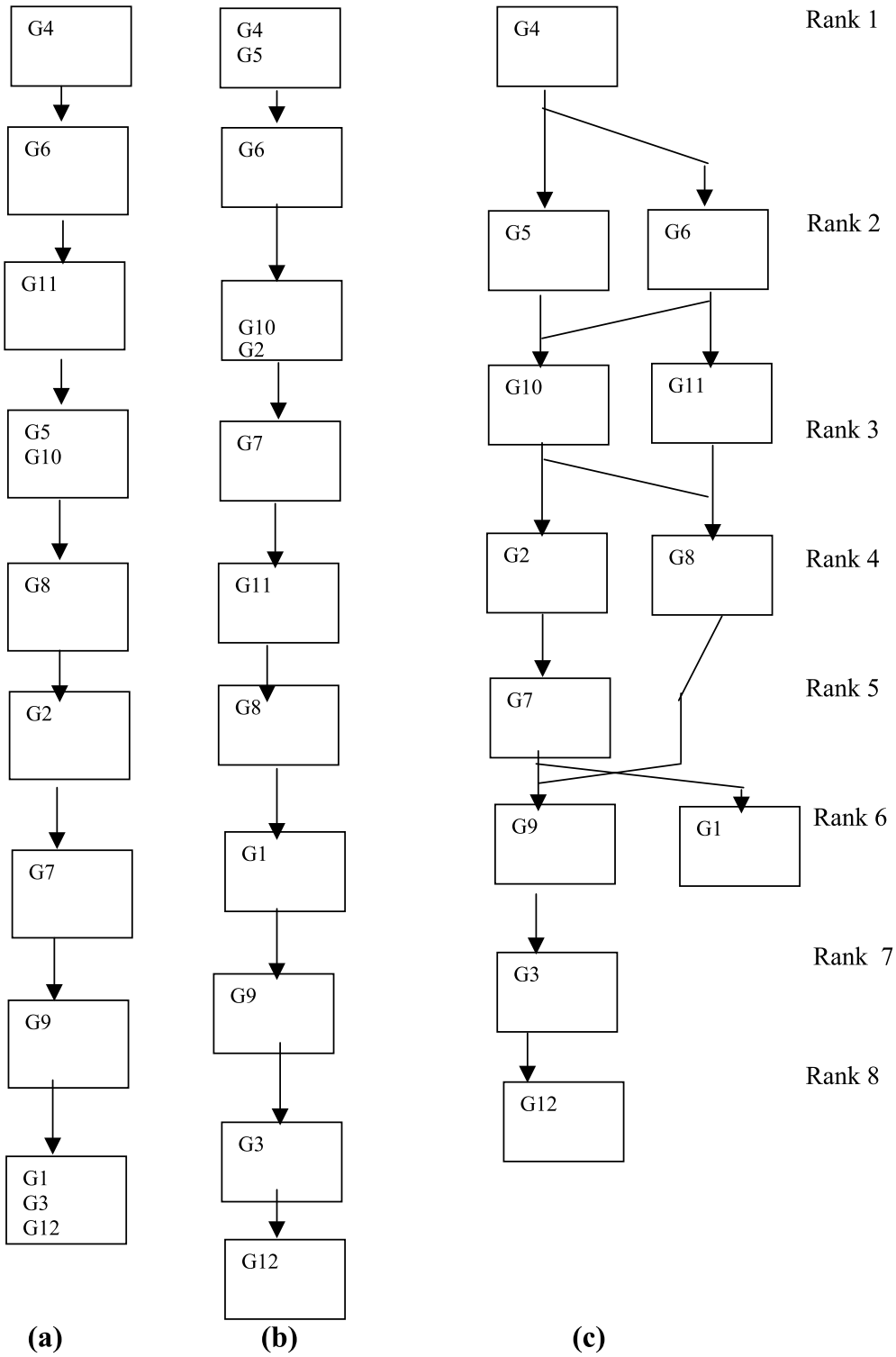

Figure 2 | (a) Descending, (b) ascending, (c) final distillation corresponding to ELECTRE-3 without veto thresholds for distillation coefficients $(-0.15, 0.3)$.

Table 6 | Ranking patterns obtained by ELECTRE-3

	G1	G2	G3	G4	G5	G6	G7	G8	G9	G10	G11	G12
Without veto	6	4	7	1	2	2	5	4	6	3	3	8
With veto	3	3	3	3	2	1	3	3	5	4	3	3

Table 7 | Credibility index of ELECTRE-3 with veto thresholds

	G1	G2	G3	G4	G5	G6	G7	G8	G9	G10	G11	G12
G1	1.00	0.00	0.00	0.00	0.00	0.00	0.00	0.00	0.00	0.00	0.00	0.00
G2	0.00	1.00	0.00	0.00	0.00	0.00	0.00	0.00	0.00	0.00	0.00	0.00
G3	0.00	0.00	1.00	0.00	0.00	0.00	0.00	0.00	0.00	0.00	0.00	0.00
G4	0.00	0.00	0.00	1.00	0.00	0.00	0.00	0.00	0.00	0.00	0.00	0.00
G5	0.00	0.00	0.00	0.00	1.00	0.00	0.00	0.00	0.90	0.00	0.00	0.00
G6	0.00	0.00	0.00	0.00	0.00	1.00	0.00	0.00	0.94	0.80	0.00	0.00
G7	0.00	0.00	0.00	0.00	0.00	0.00	1.00	0.00	0.00	0.00	0.00	0.00
G8	0.00	0.00	0.00	0.00	0.00	0.00	0.00	1.00	0.00	0.00	0.00	0.00
G9	0.00	0.00	0.00	0.00	0.00	0.00	0.00	0.00	1.00	0.00	0.00	0.00
G10	0.00	0.00	0.00	0.00	0.00	0.00	0.00	0.00	0.00	1.00	0.00	0.00
G11	0.00	0.00	0.00	0.00	0.00	0.00	0.00	0.00	0.00	0.00	1.00	0.00
G12	0.00	0.00	0.00	0.00	0.00	0.00	0.00	0.00	0.00	0.00	0.00	1.00

Correlation analysis

The Kendall rank correlation coefficient (τ) is a nonparametric measure of association. Its possible values range from -1 to 1 . The absolute value of the coefficient indicates the strength of the relationship, with larger values indicating stronger relationships. The sign of the coefficient indicates the direction of the relationship. In the present study the Kendall rank correlation coefficient is employed to determine the measure of association between ranks obtained by two scenarios, i.e. with and without veto thresholds. More information on the above method is available in Connolly & Sluckin (1953). It is

observed that the τ value between these two scenarios (with reference to Table 6) is 0.3090 at the 2-tailed significance level of 0.213 . A low value of correlation coefficient is observed mainly due to ties in the ranking pattern in both the scenarios.

Sensitivity analysis

Sensitivity analysis is performed to check the effect of thresholds and distillation coefficients on the ranking pattern. Various combinations of thresholds and distillation coefficients are employed. In the present paper only

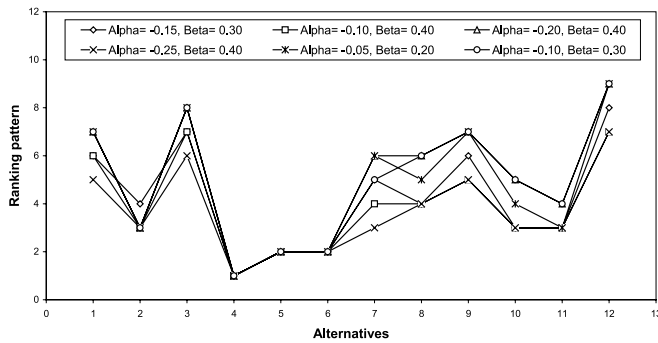

Figure 3 | Ranking patterns for various distillation coefficients (for indifference and preference threshold values of 0 and 10).

limited results are presented. Interested readers may contact the authors for complete results. Details of runs are as follows:

1. Two sets of thresholds, i.e. indifference, preference and veto thresholds of (0,10,15) and (10,15,30).
2. Six sets of distillation coefficients (− 0.15,0.3), (− 0.1,0.4), (− 0.2,0.4), (− 0.25,0.4), (− 0.05,0.2) and (− 0.1,0.3).

Figure 3 presents the ranking patterns corresponding to indifference and preference threshold values 0 and 10 (without veto thresholds) for the above six sets of distillation coefficients. It is observed from Figure 3 that alternative strategies G4, G5 and G6 occupy the first three positions for all six sets of distillation coefficients. Figure 4 presents the ranking pattern for the above case with consideration of the veto threshold (15 in this case). The ranking pattern is the same for all the distillation coeffi-

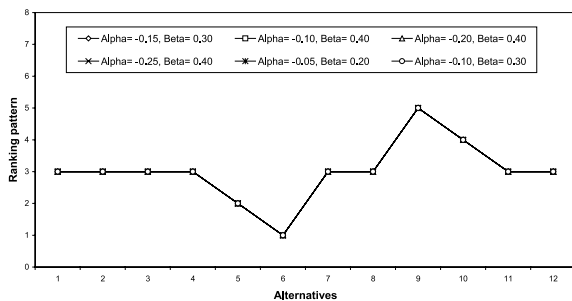

Figure 4 | Ranking patterns for various distillation coefficients (for indifference, preference and veto threshold values of 10, 15).

Table 8 | Kendall rank correlation coefficient values for various thresholds and distillation coefficients

Distillation and veto coefficients	(q=0, p=10, v=15)	(q=10, p=15, v=30)
(− 0.15,0.30)	0.3090	0.6958
(− 0.10,0.40)	0.3141	0.5249
(− 0.20,0.40)	0.3679	0.6159
(− 0.25,0.40)	0.3621	0.6728
(− 0.05,0.20)	0.3679	0.7763
(− 0.10,0.30)	0.3883	0.5724

icients, indicating that ranking pattern is independent of distillation coefficients. In this scenario G6 and G5 occupy the first and second positions, respectively. The Kendall correlation coefficient is computed between the ranking patterns obtained with and without veto thresholds. Results are presented in Table 8 where low correlation values in the range of 0.309–0.3883 are observed. This may be due to multiple ties in the ranking pattern.

Similarly Figure 5 presents the ranking patterns corresponding to indifference and preference threshold values 10 and 15 (without veto thresholds) for the above six sets of distillation coefficients whereas Figure 6 represents ranking patterns for the above case with consideration of

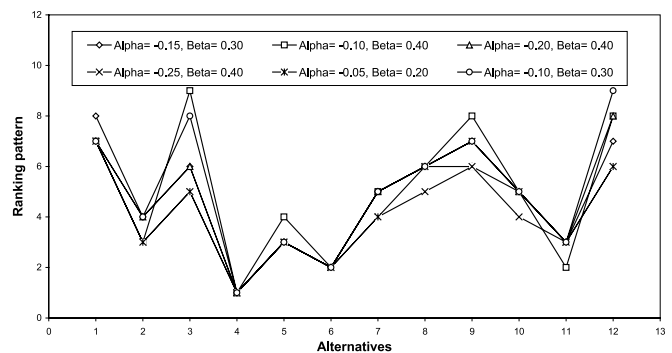

Figure 5 | Ranking patterns for various distillation coefficients (for indifference and preference threshold values of 10 and 15).

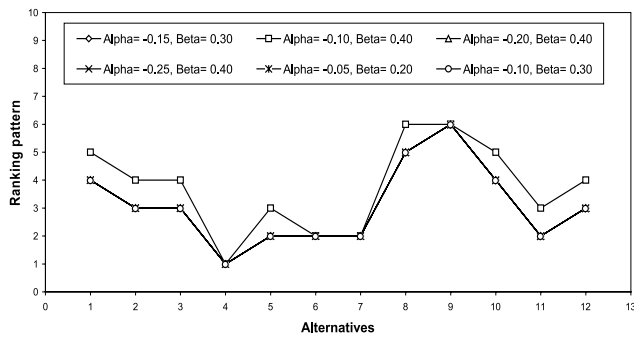

Figure 6 | Ranking patterns for various distillation coefficients (for indifference, preference and veto threshold values of 10, 15, 30).

veto thresholds (30 in this case). It is observed that alternative strategy G4 occupies the first position. It is observed from Table 8 that a good correlation value of 0.7763 is observed for a distillation coefficient set of $\alpha = -0.05$ and $\beta = 0.2$. The range of Kendall correlation coefficient values is 0.5249–0.7763. It is observed from the above results that the effect of thresholds on the ranking patterns is significant even though the position of the top three alternative strategies remains unchanged.

Considering all the scenarios along with extensive sensitivity analysis it is concluded that alternative strategy G4 (a combination of surface irrigation system, without changes in the existing water pricing, allocation policy, subsidy policy, growing wheat/barley using green fertilizer), G5 (a combination of sprinkler irrigation system, without changes in the existing water pricing, allocation, fertiliser and subsidy policy, growing fruit/vegetables), G6 (a combination of sprinkler irrigation system, without changes in the water allocation, fertiliser and subsidy policy, growing fruit/vegetables and increase of existing water pricing by 10 pta/m³) are found to be suitable in that order for further in-depth analysis with precise numerical data for subsequent implementation.

CONCLUSIONS

ELECTRE-3, an MCDM technique of outranking nature, has been applied to sustainable water resources planning

for the case study of the Flumen Monegros irrigation area in the Huesca province of Spain and the following conclusions may be drawn:

- Alternative strategy G4 (a combination of surface irrigation system, without changes in the existing water pricing, allocation policy, subsidy policy, growing wheat/barley, using green fertiliser), G5 (a combination of sprinkler irrigation system, without changes in the existing water pricing, allocation, fertiliser and subsidy policy, growing fruit/vegetables), G6 (a combination of sprinkler irrigation system, without changes in the water allocation, fertiliser and subsidy policy, growing fruit/vegetables and increase of existing water pricing by 10 pta/m³) are found to be preferred in that order.
- Cluster analysis has been utilised as a screening tool in the present analysis and found to be suitable to make decision-making much more effective; alternatively, ELECTRE-TRI may be used as a screening technique as was done in Raju *et al.* (2000).
- One hundred and sixty-one alternative strategies are partitioned into twelve groups. An alternative strategy from each group is selected based on the minimum squared error methodology from the group mean.
- The analysis shows that the effect of thresholds is significant on the ranking pattern even though the position of the top three alternative strategies remains unchanged.
- The Kendall rank correlation coefficient is found to be suitable to find the correlation between the various ranking patterns. It is observed that the Kendall τ value is 0.3090 with a 2-tailed significance level of 0.213.
- The sustainability concept is introduced into the planning problem by incorporating criteria such as water volume, water quality after irrigation, efficiency of water use, resistance to floods or droughts and employment of rural labour, especially unskilled labour.

ACKNOWLEDGEMENTS

The authors are grateful to Professor Vladan Babovic, Editor, *Journal of Hydroinformatics* for his valuable guidance during revision of the manuscript.

REFERENCES

- Breuil, L., Cadilhon, J. J., Maurel, F. & Duckstein, L. 2000 Multiobjective management of an irrigated area in the Ebro basin Spain. EURO XVII, 17th European Conference on Operational Research, Hosted by the Hungarian Operational Research Society (HORS), Budapest, Hungary.
<http://www.sztaki.hu/conferences/euro17/author-index.html/>
- Buchanan, J., Sheppard, P. & Vanderpooten, D. 1999 Project ranking using ELECTRE-III.
<http://www.mngt.waikato.ac.nz/depts/mnss/john/Electwp.pdf>
- Connolly, T. G. & Sluckin, W. 1953 *An Introduction to Statistics for the Social Sciences*. Cleaver-Hume Press, London.
- Country Profile-Spain. 2000 http://www.icid.org/cp_spain.html
- Duckstein, L., Treichel, W. & Magnouni, S. E. 1994 Ranking ground-water management alternatives by multicriterion analysis. *J. Wat. Res. Plan. Mngt, ASCE* **120**, 546–565.
- Hokkanen, J. & Salminen, P. 1997 ELECTRE III and IV decision aids in environmental problem. *J. Multicriteria Decision Analysis* **6**, 215–226.
- Jain, A. K. & Dubes, R. C. 1988 *Algorithms for Clustering Data*. Prentice-Hall, Englewood Cliffs, NJ.
- Loucks, D. P., Stedinger, J. R. & Haith, D. A. 1981 *Water Resources Systems Planning and Analysis*. Prentice-Hall, Englewood Cliffs, NJ.
- Morse, J. N. 1980 Reducing the size of the nondominated set; pruning by clustering. *Comput. Oper. Res.* **7**, 55–66.
- Pomerol, J. Ch. & Romero, S. B. 2000 *Multicriterion Decision in Management: Principles and Practice*. Kluwer, Dordrecht.
- Raju, K. S., Duckstein, L. & Arondel, C. 2000 Multicriterion analysis for sustainable water resources planning: a case study in Spain. *Wat. Res. Mngt* **14**, 435–456.
- Rogers, M. & Bruen, M. 2000 Using ELECTRE III to choose route for Dublin port motorway. *J. Transport. Engng, ASCE* **126**, 313–323.
- Rogers, M., Bruen, M. & Maystre, L.Y. 2000 *ELECTRE and Decision Support Methods and Applications in Engineering and Infrastructure Investment*. Kluwer, Dordrecht.
- Roy, B., Slowinski, R. & Treichel, W. 1992 Multicriterion programming of water supply systems for rural areas. *Wat. Res. Bull., AWRA* **28**, 13–31.
- Szidarovszky, F., Gershon, M. & Duckstein, L. 1986 *Techniques for Mutliobjective Decision Making in Systems Management*. Elsevier, Amsterdam.
- Tuan, N. D. & Thanh, L. D. 1999 Some aspects of river basin management in Vietnam. In *River Basin Management* (ed. Mostert, E.), pp. 243–248. Technical Documents in Hydrology, International Hydrological Programme, UNESCO, Paris.
- Vadas, R.G. 1999 The Sao Francisco river basin. In *River Basin Management* (ed. Mostert, E.), pp. 97–114. Technical Documents in Hydrology, International Hydrological Programme, UNESCO, Paris.
- Vallée, D. & Zielniewicz, P. 1994 *ELECTRE III-IV, version 3.x – Aspects méthodologiques*, Université de Paris-Dauphine, Document du LAMSADE no 85.