



Powder pneumatic injection as a tool for wastes utilization

J. Jezierski*, K. Janerka

Division of Foundry, Institute of Engineering Materials and Biomaterials,
Silesian University of Technology, ul. Towarowa 7, 44-100 Gliwice, Poland

* Corresponding author: E-mail address: jan.jezierski@polsl.pl

Received 10.01.2009; published in revised form 01.04.2009

ABSTRACT

Purpose: Metallurgical process generates many solid, gaseous and liquid wastes. Nowadays when environmental protection is one of the most important problems and when pollution limits are very tight as well, problem of the metallurgical wastes is a strategic one.

Design/methodology/approach: In present days the metallurgical and foundry plant have to utilize their own wastes, especially these which are the most dangerous and toxic or have to render harm of its and transfer to another industry branch for further utilization. Nowadays the issue of wastes management has the place both in industrial practice and scientific field too. The presented work is a result of such an approach, where a cooperation between scientific and industrial partners gives good economical and ecological results.

Findings: One of the very efficient method of utilization of furnace dusts from any melting furnace or the finest fractions of charging materials is pneumatic powder injection directly into molten metal bath. The method is pretty easy and cost effective in various conditions and its flexibility allows to implement it in almost every foundry or metallurgical plant.

Research limitations/implications: Further experiments should be carried out to solve some additional problems appearing during powder injection processes to make them more efficient in various technological conditions.

Practical implications: Nowadays in Poland operate more than ten industrial stands for powdered carburizers injection, installation of furnace dust injection back to the melting furnace or pneumatic inoculation of alloys (mostly in cast iron foundries).

Originality/value: The paper presents a few modern solutions for recycling and utilization of furnace dusts (in cupolas and EAF's) and pneumatic carburization with use of powdered carburizers which are very often in form of grinded graphite electrodes wastes. All of the mentioned results and method had been developed in Department of Foundry and some of the designs had been previously patented.

Keywords: Cleaner production; Industrial application of cleaner production methods; Casting; Powder injection; Injection lance

Reference to this paper should be given in the following way:

J. Jezierski, K. Janerka, Powder pneumatic injection as a tool for wastes utilization, Archives of Materials Science and Engineering 36/2 (2009) 118-124.

MATERIALS MANUFACTURING AND PROCESSING

1. Introduction

Metallurgical process is widely known to be a source of various wastes. Some researchers claimed [1-4] that in whole wastes amount very important part is dust caught by dust removal installations of melting furnaces. The next group are the finest fractions of charging materials (carburizers, ferroalloys, inoculants) which are sometimes very difficult to use in classical methods of alloys production. Nowadays when environmental protection is one of the most important problems and when pollution limits are very tight as well [5-7], problem of the metallurgical wastes is a strategic one. In present days the metallurgical or foundry plant have to utilize their own wastes, especially these which are the most dangerous or have to render its toxicity and transfer to another branch for utilization [1,2,8].

Since Poland has been a part of EU our metallurgy and foundry industries stay in front of problems, which in "old" EU countries have been worked out with good results already [9-11]. Nowadays the issue of waste management both in metallurgy and foundry industry found out the place both in practice and science as well. The work is a result of such an approach, giving the examples where a cooperation between scientific and industrial partners gives new solutions to achieve the good economical and ecological results.

One of the method of utilization of furnace dusts from any melting furnace or the finest fractions of charging materials is pneumatic powder injection into metal bath. In Department of Foundry, Silesian University of Technology in Gliwice, Poland, the experiments with use of pneumatic conveying in this field have been done successfully for many years. Nowadays, in Poland operate more than ten industrial stands for powdered carburizers injection, installation of furnace dust injection back to the melting furnace or pneumatic inoculation of cast iron [12-15].

The paper presents a few modern solutions of recycling and utilization of furnace dusts (in cupolas or electric arc furnaces) and pneumatic carburization with use of powdered carburizers which are very often in form of grinded graphite electrodes wastes [16-17].

2. Application of pneumatic injection for wastes utilization

Casting or metallurgical processes generate wastes in form of dust in a large quantity but these materials can be used as a valuable materials being re-introduced into melting process. This section describes some application developed and implemented in mainly Polish foundries or metallurgical plants.

2.1. Dusts injection into cupola

According to previous researches [2,4,18] cupola process generates from 4 to 15kg of dust per 1Mg of cast iron and this value depends on charging materials set, cupola type and quantity of coke used (except of coke-less cupolas). In Germany [18] cupolas generate more than 30000 Mg of dust per year. In this

type of dust there are many valuable elements which are unfortunately very harmful (mainly Zn, Pb, Cd). Content of Fe is generally greater than 10% so the dust is in its own a valuable charging materials. When the dust contains more than 15%C it can be an extra source of heat energy and could be a valuable fuel. Since, as currently greater and greater share in charge materials for cupolas (in some cases up to 40%) has a automotive scrap, mainly zinc coated sheet, the serious problem can be a high content of zinc in cupola dust. The zinc content in the dust may increase up to 20% what causes that such dust can be use as a charge material for metallurgical process in zinc metallurgical plant. Moreover repeated recirculation and introduction of dusts into cupola causes, that economical indexes of its usage increase. But repeated use of dusts requires either use of proper technology (pneumatic powder injection) or its briquetting and introduction into furnace in this form [3]. In Department of Foundry the experiments were carried out in the field of pneumatic dusts re-introduction, which result was application of several installations, what is described in the paper on the example of two Czech based on cupolas foundries.

In the first case the problem of pneumatic injection of cupola dust, small fractions of FeSi (wastes) and ground anthracite mixture have been solved. The solution was selected after preliminary tests, which point at the big problems with uniform proportioning and pneumatic conveying cupola dust only. The properties of materials being introduced into cupola have been shown in Table 1.

Table 1.
Properties of the powdered materials injected into cupola

Material	Bulk density (kg/m ³)	Granularity (mm)	Humidity (%)
Anthracite	880	0-2	<2.8
FeSi	1860	0-3	<1.3
Cupola dust	630	<0.5	<3.5

For the experiments mentioned above materials were used and their mixtures: anthracite + FeSi (50% + 50% mass) and cupola dust + FeSi (50% + 50% mass). The mixtures were prepared to make the material easier to pneumatic transport. The pneumatic injection installation was based on chamber feeder of POLKO system (one of the best Polish companies supplying pneumatic conveying installations for various industries) with capacity $V_n = 0.25 \text{ m}^3$ [15]. The feeder was equipped with electronic control system and precise dosing system exactly inside the predicted mass flow range (2-5 kg/min). The continuous recording of the feeder's mass changes with accuracy $\pm 0.1 \text{ kg}$ makes possible to real-time estimation of powdered material outflow and in the same way efficiency of the whole injection installation. The specific conditions of melting in cupola require that dosage time (with good stability) should be about 2 hours. During the experiments the powdered material was conveyed through elastic pipe of $L=25 \text{ m}$ length and inside diameter $d_w=0.025 \text{ m}$ from pneumatic feeder to the end of installation (cupola). Moreover the design changes of the mixing chamber have been made to improve material with carrier gas (compressed air) mixing and following transportation. The porous liner at the

bottom of the feeder was used to allow fluidization of powdered material inside it.

The research assumptions include strictly given range of the powdered material mass flow $m_c = 0.033\text{--}0.083$ kg/s (2-5 kg/min) but the very important parameter is the conveying stability during working cycle.

The values obtained during experiments for mass flow rate of powdered material were in the range $m_c = 0.0332\text{--}0.1075$ kg/s (2-6.5 kg/min) and were more or less inside required range given for this parameter. The preliminary researches carried out were the base for selection of design parameters of the real injection system (the supplying nozzle diameter $d_3 = 5\text{mm}$) and pressure of the carrier gas ($p_3 = 0.3\text{--}0.4$ MPa) what guarantee the stability of the diphase stream flow.

The proposed system connected to cupola nozzles makes possible to utilize the all amount of dust from dust extraction system and the injection process does not affect negatively the produced alloy quality. The method is easy, safe and very efficient and what is most important enables to meet the highest environmental standard pollution limits. The result of that work was implementation of the technology for simultaneous pneumatic carburizing, desulphurization and dust injection. The examples of installations of sucked dust re-introduction together with other pulverized materials into cupola were presented on Figures 1 and 2.

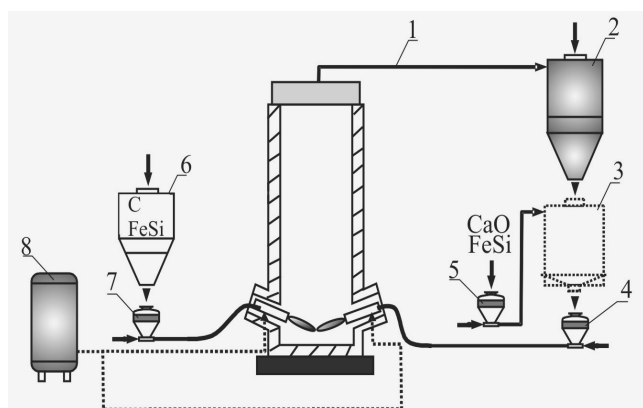

Fig. 1. Installation of pneumatic powder injection into cupola; 1-dust removal system, 2-container, 3-fluid mixer, 4-feeder, 5-chamber feeder, 6-container, 7-chamber feeder, 8-storage container

The carried away through the dust removal system (1) into container (2) cupola dust thanks to presented stand is again introduced into technological process by pneumatic injection technique. It enables the recovery of waste materials created during metallurgical processes. Earlier this material was removed from the plant to utilization in another what generated the high costs. In presented solution the proper composition of the mixture was obtained with use of fluid mixer (3) and the chamber feeder (5). Such a mixture was injected by the feeder (4) into cupola. However, the second system of the container (6) and chamber feeder (7) can realize another process at the same time (carburization of liquid bath). Both processes can be performed with the use of the oxygen-fuel burners with oxygen supplying from storage container (8).

The presented modernization of the cupola provided the following results:

- remarkable reduction of production costs,
- increase of the cupola effectiveness to c.a. 50%,
- coke consumption decrease by c.a. 10%.

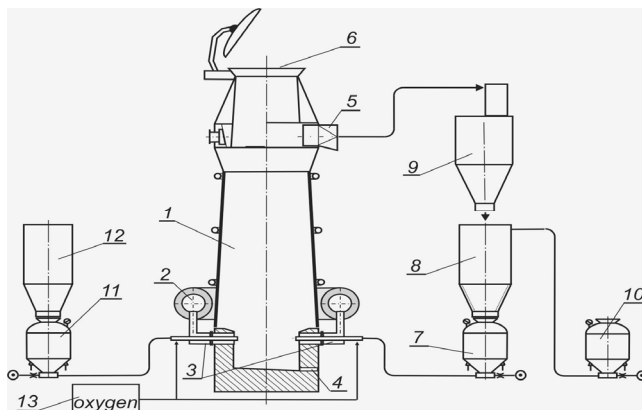

Fig. 2. Industrial stand for dust and carbon injection into cupola; 1-cupola, 2-airbox, 3-cupola nozzles, 4-tapping hole, 5-gas exhaust system, 6-charging door, 7-dust and coal pneumatic feeder, 8-dust and coal storage container, 9-dust receiver, 10-coal pneumatic feeder, 11-alloy additions pneumatic feeder, 12-alloy additions storage container, 13-oxygen supply

2.2. Pneumatic dusts injection into EAF

During steel-making process the enormous amounts of the wastes in the form of dust are generate. In North America, about 700 000 Mg/year, in Europe about 900 000 Mg/year, in Japan about 450 000 Mg/year and in Poland about 60 000 Mg/year are generated [19,20]. More than 30% of steel is presently melted in electric arc furnaces (EAF) where the greatest problem is utilization of dust with high zinc. Owing to this, in the 1990s experiments were performed to return dust back to a melting unit [7,10,20]. Department of Foundry of Silesian University of Technology has recently performed the research and industrial implementation of the installation for dust pneumatic injection back into 65 tons EAF. The furnace dust was mixed with coal dust in the ratio of 3 to 1. The carrier gas was dried air and the injection process was performed for slag foaming. The average chemical composition of furnace dust has been shown in Table 2.

Table 2.
The chemical composition of the furnace dust

Material	Content (%)	Material	Content (%)
Fe	20.61	FeO	2.53
SiO ₂	3.12	Al ₂ O ₃	0.61
CaO	3.19	MgO	2.20
Mn	3.19	Zn	30.63
Pb	5.80	K ₂ O	2.04
Na ₂ O	2.42	P	0.15
S	0.67	C	0.92
F	0.20		

During the experiments the significant difficulties with proper dust transportation were observed mainly with feeder evacuation. The dust was hung-up inside the feeder (problem presented on Figure 3) and it was impossible to force it to get out with only pneumatic parameters (pressures in installation) adjusting. So after the series of experiments was decided that the feeder with porous liner at the bottom should be used instead of its normal design. The modernized mixing chamber of the dispenser has been shown in Figure 4 and this constructional design made possible to achieve the uniform working cycle of the dust injection installation.

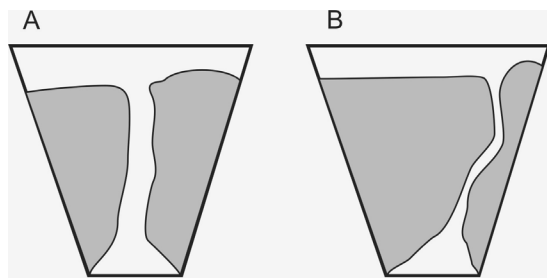

Fig. 3. The material hung-up in the pneumatic feeder; A and B – two typical appearances of material hang-up

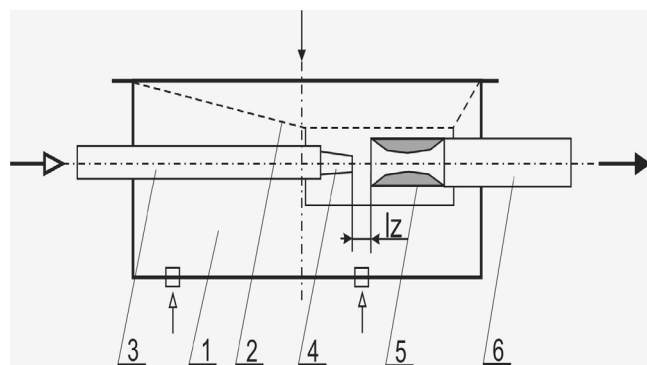

Fig. 4. Mixing chamber of the pneumatic feeder of dust: 1-frame, 2-porous liner, 3-compressed air supply, 4-replaceable regulation nozzle, 5-interceptive cone, 6-conveying pipeline, lz-distance between replaceable elements

The prototype of the system for dust recycling and slag foaming was connected to 65 tons electric arc furnace operates in one of the Polish metallurgical plants. It supplies the continuous steel casting line and is characterized by the following parameters:

- the furnace dust grain size: 0.005-0.5 mm,
- bulk density of dust: 489 kg/m³,
- the powdered coal grain size (it was a part of the mixture injected into furnace): 0-3 mm,
- bulk density of coal: 667 kg/m³,
- the maximum amount of the mixture injected during one heat: 1330 kg,
- mass composition of the mixture: 75% of dust + 25% of coal,
- injection time: 10-15 min,

- system capacity: 0.5-2.2 kg/s,
- unitary oxygen consumption: 2-4 m³/Mg,
- unitary dust consumption: 5-11 kg/Mg,
- unitary coal consumption: 1-3 kg/Mg.

After the series of experiments in laboratory conditions of the Department of Foundry and later, in industrial conditions of the client's metallurgical plant the complete installation was designed as has been shown in Figure 5.

During the industrial experiments 278 controlled heats were performed in total giving really good results and confirmed the capability of this technique. No significant problems with installation functioning were detected after it was commissioned and adjusted.

The conditions of commissioning were as follows:

- 42 heats with the coal injection only,
- 69 heats with coal-dust mixture injection of composition: 25% of coal and 75% of dust during heat working stage,
- 167 heats with mixture injection with composition: 90% of dust and 10% of coal during melting stage and heat working in conditions as mentioned above.

On the basis of the laboratory and industrial test it has been stated that the pneumatic injection method is almost perfect for utilization of own furnace dusts in plant being analyzed. The dust recycling caused that the dust were enriched to c.a. 30% of zinc and c.a. 5% of lead and technical parameters of the heat and properties of the steel were not affected.

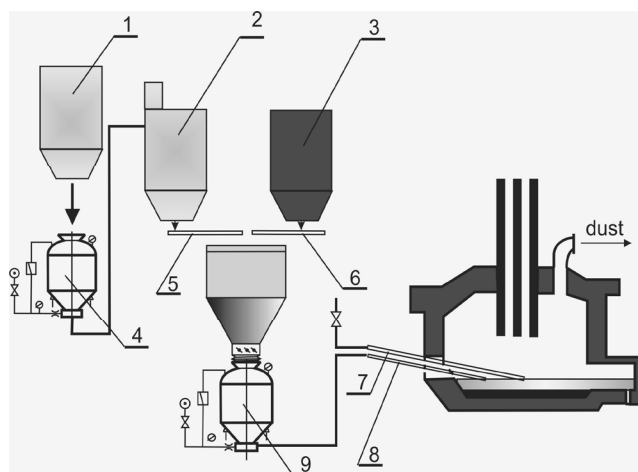

Fig. 5. The installation for dust-coal mixture pneumatic injection into 65 tons EAF: 1-furnace dust container, 2-intermediate dust container, 3- powdered coal container, 4- dust pneumatic feeder, 5-dust feeding screw, 6-coal feeding screw, 7-oxygen lance, 8-mixture injection lance, 9-mixture pneumatic feeder

Thanks to slag foaming with use of the injection of dust-coal mixture the consumption of coal and an oxygen consumption were considerably decreased in comparison to injection powdered coal only. Summing up, the pneumatic injection provided in this case both ecological and economical solutions and gave very interesting results.

2.3. Pneumatic recarburization of the liquid metal bath

The next group of the materials which can be managed in foundries (especially of cast iron) comprises steel scrap, crushed graphite electrodes and dust wastes from electrodes production process [14,16,22]. In many foundries cast iron melting process is based on charge which include a pig iron and process scrap. It ensures proper carbon content in liquid metal bath without necessity of its complement. Steel scrap because of its low carbon content (0.1-0.2% C) is for many foundries an uninteresting material from production point of view. However it contains a low sulfur and phosphorus content too, which permits its use even for ductile iron production. It is of great importance a fact of introduction of steel scrap instead of pig iron, which production consummates a large energy quantities and is very harmful for environment. The steel scrap is from economical point of view much cheaper charge material than pig iron [16]. But the problem of carbon deficit in liquid cast iron appears when we replace the pig iron by the steel scrap. So we have to recarburize the liquid metal bath by various methods but one of the best is the pneumatic injection of carburizers.

The most often used carburizers are: natural and synthetic graphite, calcinated petroleum coke and calcinated anthracite. They should have a big content of carbon and small content of ash, sulfur and low humidity. These materials are often taken from crushed graphite electrodes grinding processes from various industries or electrodes production scrap. As a carburizers could be used even the dust generated during graphite electrodes production process.

Carburizers can be introduced with solid charge materials, put on liquid metal bath surface or injected into molten metal with carrier gas. The selection of appropriate recarburization method depends on the carburizer grain size [12,15,16]. With charge materials could be introduced the coarse carburizers with only small quantity of dust. When carburizer is put on liquid surface must not consist of the finest fractions because they will be remove by dust removal installation. The harm for workers is sometimes a problem too. With use of the pneumatic injection technique can be introduce both dust and coarser grains.

Moreover, liquid metal could be kept for long time with constant temperature. In such furnace the great level of stability can be obtained what is impossible in case of other furnaces. The very high effectiveness of the recarburization process can be achieved up to 80-90%. In EAF's the metal bath has a small depth and the liquid surface is vast. There are the intensive mixing zone in it (around the electrodes) and much bigger 'dead' zones with minimal metal movement. It cause that putting the carburizers on the bath surface is non-effective and time-consuming. However, during pneumatic carburizer introduction a carrier gas forces the liquid metal movement and causes the intensive reaction substrates diffusion from reaction zone what in consequence improve the mass exchange process. Powdered carburizer is injected in carrier gas jet below the liquid surface [19]. The large contact surface between carburizer and liquid metal together with bath mixing cause that very high effectiveness and short time of the process can be obtained. By this method the deficit of carbon in liquid can be corrected with the effectiveness up to 95%. The small depth of the liquid bath allows the lance immersion close to

metal surface and the lance damage problem is not very important. The electric arc furnace construction allows to use the compressed air as a carrier gas without dangerous metal splashing or spattering effect. Therefore in EAF's and gas-fired cupolas the pneumatic recarburization technique can be the first choice [15].

2.4. Pneumatic recarburization stand

The installation for pneumatic injection process consists of several systems. The main part is pneumatic feeder 1 (Fig. 6) of typical capacity from 0.25 to 1.0 m³. The feeder is equipped with a bell valve closing on its top and the mixing chamber 3 at the bottom. That chamber is the place where powdered material mixes with the carrier gas and creates diphas solid-gas mixture. The decompression valve is mounted on the feeder and makes possible its decompression after the injection process. The pressure of the carrier gas can be adjusted with reducer 4 in the range appropriate for powdered particles transportation through pipeline. Supplying or cutting of the gas flow enables main valve 10. All the valves can be operated with use of the control switchboard 2 manually or the process can be fully computerized. The feeder is mounted on the electronic scales 5 so the material can be injected in pre-defined portion or according to planned cycle. The carburizer is conveyed through pipeline 11 and through the lance 13 is injected into electric arc furnace 14. The lance can be mounted on the manipulator 12 which make it easier to operate. Above the feeder container 7 with stock of the carburizer can be situated. The capacity of it is normally for 24h or so operational time. The screening sieve 8 is mounted in the feeder's top to prevent addition of the impurities or oversize particles into carburizers being injected. Between feeder and mixing chamber there is some kind of the swivel damper 6.

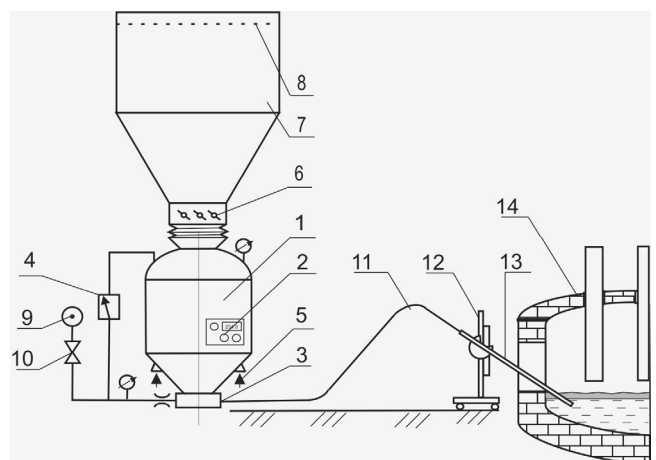

Fig. 6. Installation for the pneumatic recarburization of the liquid bath; 1-pneumatic feeder, 2-control switchboard, 3-mixing chamber, 4-reducer, 5-electronic scales, 6-swivel damper, 7-container, 8-screening sieve, 9-compressed air supply, 10-main valve, 11-pipeline, 12-manipulator, 13-lance, 14-electric arc furnace

The installation shown on Fig. 6 is not complicated and the design was well checked in various industrial conditions of mainly Polish foundries. The high-pressure conveying employed in this injection system enables to use the powdered carbon materials in the wide range of particle size, shape and density.

The carried out researches of pneumatic recarburization with use of powdered carburizers showed that great importance for rate and efficiency of the process have the diphasic stream (gas-powder) parameters. The parameters depend on the other hand on design solution of the pneumatic feeders. The feeders [12] offered on the market enable control gas of a flow rate in the range from 0.03 to 0.20 kg/s. The gas flow rate is a parameter that directly influences (in non-changeable geometry of the installation) on the gas and carburizer particles outlet velocity. As a consequence, proper diphasic stream dynamics may be achieved [22]. The parameters have to ensure the stable transportation of the powdered material and the appropriate particles range in liquid metal bath and significant bath agitation.

The small material particles flow rate causes the effectiveness increasing but the process time lasts longer and the metal temperature decrease is higher. But excessive value of the mass flow of injected material may cause that some amount of carburizer may not dissolve and will not be assimilated by liquid metal and will be deposited in slag on the metal surface. Obviously the values of mentioned parameter are strongly connected to method of melting and melting furnace type. When the diphasic stream flow rate is set badly the effectiveness of the recarburization process may reach only 40-50% [15].

The pneumatic recarburization in conditions of the inductive furnaces is a much more difficult issue because of its construction (small furnace diameter and its big depth). The industrial experiments proved that opinion undoubtedly. Such bad experiences give the data for experiments in laboratory conditions and some positive results were obtained [12]. First of all as a carrier gas should be used the inner gas (argon or nitrogen) what greatly limits the disadvantageous metal spattering. The less flow rate of the powdered material should be set to ensure the best carbon assimilation during injection process without flowing out to the surface. The proper process run require lance submersion in liquid at high depth and the problems of lance durability appear. The advantage of the inductive furnace is the electromagnetic stirring what makes better the distribution of carburizer throughout metal volume [19,22].

The experiments indicate possibility to achieve the significant carbon content increase by use of the pneumatic injection technique both in cast iron and cast steel and make possible the cast iron production with no pig iron. In such a case the considerable amount of the carburizer is added along with solid charge material on the furnace bottom and next the process of injection corrects of carbon content in liquid [16]. As a result the melting time is decreased and costs are less in comparison to method with injection the whole amount of required carburizers. The usage of the steel scrap and the carburizers from crushed electrodes reveals that the pneumatic injection method is important method for environmental protection in that field. The properties of the produced alloys are the same or even better when we use pneumatic injection than without this technique in production process and with pig iron in solid charge [16].

3. Conclusions

In the paper the usage of pneumatic powder injection technique for wastes utilization was presented. The foundry industry generates hundreds of thousands tons a year of dusts of various composition as well as other small-grained wastes. Among them there is plenty of solid wastes which after special preparation or even "as sucked" can be pneumatically injected into every type of metallurgical or foundry furnaces. The experiments in this field were carried out in Department of Foundry, Silesian University of Technology. The presented examples showed the way how the technique could be used to utilize furnace dust sucked from various types of furnaces, crushed electrodes scrap or the finest fraction of charging materials and so on. The results of author's experiments proved the effectiveness of this method for wastes utilization in furnaces. The ecological and economical indices of industrial application are at least satisfactory so the interest of the foundry industry continuously increases. Many Polish metallurgical plants and foundries utilize this technique at the moment or plan to apply it in the nearest future. It is more important nowadays when every process technology should meet very strict environmental and healthy international standards and the BAT techniques are a must for producers.

References

- [1] M. Holtzer, Influence of the cast iron melting processes on environment using BAT, Archives of Foundry Engineering 7/4 (2007) 83-88.
- [2] M. Holtzer, I. Kargulewicz, A. Kijas, Possibility of utilization of cupola dust, Acta Metallurgica Slovaca 7 (2001) 9-21.
- [3] K. Smyk, M. Holtzer, Possibilities of briquetting process using for cupola dust utilization, Archives of Foundry 2/3 (2002) 121-128.
- [4] M. Holtzer, M. Niesler, C. Podrzucki, M. Rupniewski, Using cupola for recycling foundry dusts, Archives of Foundry 6/20 (2006) 111-121.
- [5] R. Nowosielski, A. Kania, M. Spilka, Integrated recycling technology as a candidate for best available techniques, Archives of Materials Science and Engineering 32/1 (2008) 49-52.
- [6] M. Spilka, A. Kania, R. Nowosielski, Integrated recycling technology, Journal of Achievements in Materials and Manufacturing Engineering 31/1 (2008) 97-102.
- [7] K. Mijanovic, Reducing dangerous waste by applying low-waste technologies, Journal of Achievements in Materials and Manufacturing Engineering 29/2 (2008) 195-198.
- [8] Y. Kakuta, K. Hirano, M. Sugano, K. Mashimo, Study on chlorine removal from mixture of waste plastics, Waste Management 28 (2008) 615-621.
- [9] R.V. Vainola, L.E.K. Holappa, P.H.J. Karvonen, Modern steelmaking technology for special steels, Journal of Materials Processing Technology 53 (1995) 453-465.
- [10] M. Ribbenhed, M. Thoren, C. Sternhufvud, CO₂ emission reduction costs for iron ore-based steelmaking in Sweden, Journal of Cleaner Production 16 (2008) 125-134.

- [11] Y. Zhang, P.V. Barr, T.R. Meadowcroft, Continuous scrap melting in a short rotary furnace, *Minerals Engineering* 21 (2008) 178-189.
- [12] K. Janerka, Parameters of the process in pneumatic liquid metal carburizing, Proceedings of the 12th International Scientific Conference "Achievements in Mechanical and Materials Engineering" AMME'2003, Gliwice-Zakopane, 2003, 403-408.
- [13] J. Jezierski, J. Szajnar, Method and new lance for powder injection into liquid alloys, *Journal of Achievements in Materials and Manufacturing Engineering* 17 (2006) 349-352.
- [14] J. Jezierski, J. Szajnar, Character of diphasic stream force in powder injection technique, *Journal of Achievements in Materials and Manufacturing Engineering* 20 (2007) 455-458.
- [15] J. Jezierski, K. Janerka, Pneumatic powder injection technique as a tool for wastes utilization, *International Journal of Environment and Waste Management* 2/6 (2008) 636-646.
- [16] D. Bartocha, K. Janerka, J. Suchoń, Charge materials and technology of melt and structure of gray cast iron, *Journal of Materials Processing Technology* 162-163 (2005) 465-470.
- [17] A.G. Borrego, E. Osorio, M.D. Casal, A.C.F. Vilela, Coal char combustion under CO₂-rich atmosphere: Implications for pulverized coal injection in a blast furnace, *Fuel Processing Technology* 89 (2008) 1017-1024.
- [18] W. Neumann, K. Wolf, Injection of materials into the cupola, *Casting Plant Technology International* 13/4 (1997) 14-17.
- [19] E. Sheepers, J.J. Eksteen, C. Aldrich, Optimization of the lance injection desulphurization of molten iron using dynamic modeling, *Minerals Engineering* 19 (2006) 1163-1173.
- [20] S. Ghorai, G.G. Roy, S.K. Roy, Submerged liquid slag injection in steel melt: scale up study using cold model and dimensional analysis, *Ironmaking and Steelmaking* 3/5 (2004) 401-408.
- [21] T. Han, A. Levy, H. Kalman, Y. Peng, Model for dilute gas-particle flow in constant-area lance with heating and friction, *Powder Technology* 112 (2000) 283-288.
- [22] J.L. Xia, T. Ahokainen, L. Holappa, Study of flow characteristics in a ladle with top lance injection, *Progress in Computational Fluid Dynamics* 1/4 (2001) 178-187.