

LASER SCANNER AND ARCHITECTURAL ACCURACY TEXT

A.Adami^a, F.Guerra^b, P.Vernier^c

^a Politecnico di Milano, DIIAR, IT [aadami@iuav.it]

^b Università IUAV di Venezia, CIRCE, IT [guerra2@iuav.it]

^c Politecnico di Milano, DIIAR, IT [vernier@iuav.it]

Commission VI, WG VI/4

KEY WORDS: Laser scanner, accuracy test, architectural survey, cultural heritage

ABSTRACT:

In last years laser scanning have increased its application in different fields: from geological to architectural and archaeological survey, from real time monitoring to rapid prototyping. Respect to architecture and archaeology, but more generally to Cultural Heritage, laser scanning technology is becoming more popular as can be proved in the latest works: big amount of data, accuracy, operability are some of its main characteristics that are fundamental in digital (numerical) models representations.

If advantages are clear, it's possible to attend to a continuous and increasing demand for better performances that correspond to the necessity to update and to implement continuously instruments respect to growing applications. In this paper authors want to point out some technical considerations on these new instruments, on their improved and improvable performances respect to their application fields. As was asserted in many experiences, laser scanner specifications, given by L.S. producers, concern to laboratory parameters so they do not correspond with practice conditions of acquisitions, which are usually more complicated and less controlled than laboratory test. Considering other well-known literatures (e.g. Boehler et al., 2005) and knowing that accuracy varies from instrument to instrument on the base of their individual calibration, some tests were done to probe not only the standard parameters of laser scanner (accuracy, density, times..) but even some features that are usually dictate from "real conditions" of acquisition: acquiring time, accuracy of measurement at different distances, feedback of different materials in the same scan, capabilities in describing simple and complex geometric properties (such as a façade of a church or a detail of a moulding), operability of different acquiring system. Moreover it was estimated the possibilities of integration between laser scanners and photogrammetry (i.e. multi-sensor integrations) and topography. As test area were chosen a part of the historical building of the university and the columned façade of a close church. We carried out all these tests using different producers laser scanners, but even different type

of the same firm in order to identify the most suitable instruments for an architectural survey.

1. INTRODUCTION

In the last years laser scanning technologies had a huge development both as applicative practice and in hardware and software improvement. Its employment in different field of application has shown laser scanning's versatility in one side, and the necessity of specifications to standardise the technique's processes and deliverables to ensure laser scanning provides the repeatable level of recording that photogrammetry, for example, currently provides.

In archaeological employments, for instance, the possibility of a continuous description of manufacture or finds totally satisfies the experts and researchers' requests. In geology, the definition of volumes and surfaces as the main demand to laser scanning, to recognize rock beds, their quantification and the identification of peculiar conditions, such as landslide.

In architecture, laser scanner's use is mostly connected to cultural and historical heritage, to its survey and documentation. Just for architecture characteristics, distinctive instrumental specifications are demanded to laser technology and to related softwares for managing and processing of data.

Considering different applications, the main and more important element to be considered in the choice of a laser scanner for architecture is the possibility of surveying and plotting complex elements. Precisely architectural details, such

as edges, mouldings, etc., define and characterize the architecture itself. These details are easily identified, surveyed and plotted by topographic and photogrammetric methods but they suddenly disappear or hardly been recognized due to an unsuitable instrument or for a bad processing of data.

Moreover some other considerations have to be done in architectural survey, such as the simultaneous presence of different building material, characterized by typical colour, texture, roughness, reflectivity which can affect different results respect to laser beam and its angle of incidence. Even all the operative and logistics aspects can influence the practicability and the success of a survey. For this reason some other parameters have to be examined: field of view, scan rate, physical dimension, weight, power supply, acquisition system's handling more as well as minimum and maximum range.

Besides all these technical characteristics, one more condition is given by the possibility of integration with other well-tested methods, such as topography and photogrammetry: a supplementary inner or external calibrated camera, the possibility of employment of topographical accessories such as tribrach for a more accurate forced centring.

Many laser scanner tests are dealt in literature considering metrical and physical aspects of different class and type of instruments: based on this knowledge a comprehensive test program was developed at i3mainz and as many different

scanners as possible are compared using the same installations (Bohler, 2003).

All these published tests discuss of methods and results concerning accuracy with laser scanners in depth, but hardly they point out which is the most suitable field of application for each of them.

This is the main reason why the presented test, that is still in progress, want to underline which is the commercial solution than can better answer to architectural requirements.

First of all the research was done defining two test areas characterized by the presence of some classic architectural elements. Next phases, acquisition, processing and elaboration, were brought on to prove some possible similarities and differences, even practical, among instruments.

Tested instruments are: Riegl LMS-Z 360I, Leica HDS 3000, Riegl LMS-Z 390 and FARO LS HE80.

2. TEST AREAS

First test area, summarizing main architectural cases, were the cloister of Tolentini, historical seat of our university, designed by Vincenzo Scamozzi in the sixteenth century and restored by Daniele Calabi in the early 1960's. In this building different materials (brick, stone, plasters, concrete,..) and architectural details can be found. Particularly, scans were focalized on the barrel and cross vaulted ceiling of the cloister, the main façade of the church with its colonnade and portal and its plastic elements, such as basements, capitals and corbels.

The second test was a level and smooth surface just to verify a typical problem of laser scanners: noise presence in 3D data.

Exactly, level surface was in a vertical position and it was scanned from different position to study laser beam's angle of incidence effect respect orthogonal condition or a slope one (45°)

Both areas were topographically surveyed to register, and study, all data in the same system of reference.

System of referenced was materialized by seven benchmarks, properly measured and adjusted. Then some control points were placed on the interest areas. Control points were materialized by different targets, respect to the necessities of each instruments (high reflecting power or radiometric differences).

3. TESTED LASER SCANNERS

Tested laser scanner belong to different categories: time of flight and phase shift distance-meters. TOF laser scanners allow to acquire very fastly measurements (about 10.000 pts/sec) with good accuracy (5-10mm). Unlike phase based ranging system present a higher accuracy than previous ones but they need longer time and a shorter in scanning acquisition (FARO).

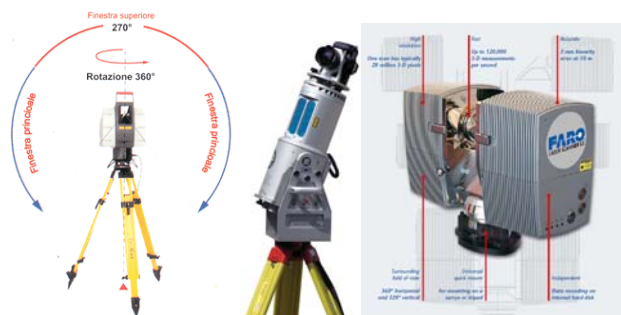

Figure 1: Leica Hds 3000, Riegl 390, Faro LS HE80

Our instrumental choice for this test was justified because these laser scanners represent practically the most widespread ones in

architectural field.

	LMS Z 360 I	HDS 3000	LMS Z 390 I	FARO
	Riegl	Leica	Riegl	Faro
Type	TOF	TOF	TOF	Phase
Range min	1 m	1 m	1 m	1 m
Range max	200m 80%	300m 90%	300m 80%	35 m 70 m
	100 m al 10%	134 m al 18%	100 m al 10%	
Accuracy	±6 mm (average)	Range 4 mm	±2 mm (average)	3mm 10 m
	±12 mm single	Position 6 mm	±6 mm single	
		Angle: mrad60		
Angle horizontal	0.0025°		0.001°	0.0007°
Angle vertical	0.002°		0.001°	0.009°
Distance		4mm (-50m)		
High speed	12000 pts/s	4000 pts/s	11000 pts/s	120.000 pts/s
Field of view O	O: 360°	O: 360°	O: 360°	O: 360°
Field of view V	V: 90°	V: 270°	V: 80°	V: 320°
Spot size	4-6 mm a 50m			3 mm
Digital camera	Calibrated	Integrated	Calibrated	
	D100		D100	
Resolution camera	6MP	1MP	6MP	
Target	Reflector	Leica	Reflector	
Dimensions	463 x 210	265 x 370 x 510	463 x 210	400 x 160
	mm	mm	mm	x 280 mm
Weight	13 kg	17 kg	14.5 kg	14.5 Kg

Figure 2: Instruments specifications.

4. DATA CAPTURE

Data capture activities (point clouds) of the Tolentini's church facade were directed considering a 1:50 scale of representation (the use of scale still provides some control as to the use of the data, providing the user with information relating to the accuracy of the information). The appropriate point density had to guarantee a pseudo-regular grid of 0.5 cm spacing.

Tested laser scanners had shown different approach in this phase yet: Riegl's ones (LMS-Z 390, LMS-Z 360) allow to define points density both as points distance (linearly) and as angle step-width between consecutive laser shot. Leica HDS enables to fix a linear grid, setting its spacing on the basis of acquisition distance. At last, Faro's scan setting is given only by an angular step.

Moreover these scanners use a tribrach for a forced centring on net points, so that it's possible to have a better control of instrumental verticality.

Substantial differences were checked in scan rate (as can see in the table below), but even in target recognition and acquisition. Different planar targets had to be used: high reflectivity is required by Riegl's laser scanners, while Faro's and Leica's

systems work on radiometric differences of well-known geometry (between the target centre and the main target surface). Target differences involve in different methods of supporting topographical survey.

All the tested scanners, due to their wide field of view (360°), use a panora scan at the beginning of acquisition, both as low density cloud (Riegl) and as raster data (Leica). Final scan is performed as described below. To be evidenced is a possibility given by Riegl to increase accuracy of single scan: scan sequence, that is averaging the results of a multiple scanning process of a same area.

Additional image data should be used to provide an overview of the subject being scanned, in addition to providing imagery for narrative purposes. This imagery should be of a high resolution and clearly portray the subject in question.

Regarding image acquisition, all the instrument are equipped with a camera, but Leica system present an integrated inner sensor with a low resolution, while Riegl's and Faro's offer the possibility to mount solidly on top of scanner a digital camera. More specifically, Riegl system is integrated functionally by a high resolution calibrated camera: the mathematical relation between the two sensors is defined by a perfect hardware calibration (effectuated beforehand by Riegl). In addition to the precise internal camera calibration, a mounting calibration guarantees a reliable correspondence of image and scan data.

5. SCANS DATA

Architectonic details, surveyed into test area, are clearly recognizable because of their different colours, shape, material and state of conservation. a panoramic scansion and a scan-sequence (Riegl) of a springer corbel was done inside the cloisters. Close to the University's inner portal, various typology of surface materials were identified: plaster area, brick wall, concrete part with the painted civic number, a capital and white carved marble. Each single element, after the panorama scan, fundamental for targets recognition, were scanned by a high density scan and by a scan-sequence (Riegl). The same acquisition process was applied for the Tolentini's church façade, particularly for a capital and a basement of the colonnade.

In order to obtain a correct interpretations of data, the each laser's point clouds were treated with the same post processing (an "inner" and an "external" one).

The inner process is composed by some operations that allow the reduction of the big amount of data by a selection of those points belonging to test area, without resampling, and the application of filters to reduce/eliminate noise and to decimate points depending on descriptive necessities. Smoothing filters for noise reduction have to remove points that present an high probability of not belonging to scanned surface. This phenomenon strongly depends on laser beam divergence, on surface's type and on environmental conditions in which acquisition is carried on. The effects of filtering data can strongly influence next workflow steps, such as architectural details surface meshing: the main risk is to eliminate them.

An effective filter for noise reduction is given by median operator as well demonstrated by other researchers (Rinaudo, 2004).

Points sampling is a process to reduce points density (resample) in order to make data homogenous and congruent respect to survey nominal scale.

Sampling process can be uniform or respect to curvature. In the first case vertex number are reduced according to an input ratio. Points can be structured in a regular grid by using an octree structure. Both sampling methods require remarkable time-

saving, even if uniform sampling has shorter computational time.

The second phase of post processing regards to an "external" treatment of data, comparable to photogrammetric orientation, that is the clouds alignment procedures and their recording in a single reference system.

We are normally used to considering at least three methods:

- geo-referencing the clouds on topographic points: this consists in a roto-translation in space (six parameters: 3 translations and 3 rotations) of every cloud in the topographic reference system;
- cloud on cloud: roto-translation of a cloud in the system inside of another. With this method, there is no external reference system but one attributes the role of global reference system to the system inside a cloud. If targets are not used for automatic recognition, registration of the points calls for a manual intervention in selection of the homologous points. The global alignment comes about through matching algorithms (fuzzy join and ICP iterative closest point), and therefore, requires a larger extension of the overlapping area between the scannings in order to improve and facilitate registration.
- spatial triangulation: it makes reference to aerial triangulation for independent models. It is the sum total of the two previous methods using both tie points and control points, guaranteeing exceptional control and minimizing the number of points surveyed topographically.

The obtained DSMs were triangulated in order to have a single surface of every scanned area.

The instruments comparison was conducted both on raw data and on final printouts, particularly regarding the smooth surface.

As it can be evidenced in paper attached images, different instruments provide different results. By capitals' surface comparison, it's clear how mouldings detection can be accurate or very hard to recognize, obviously depending to accuracy characteristics of lasers.

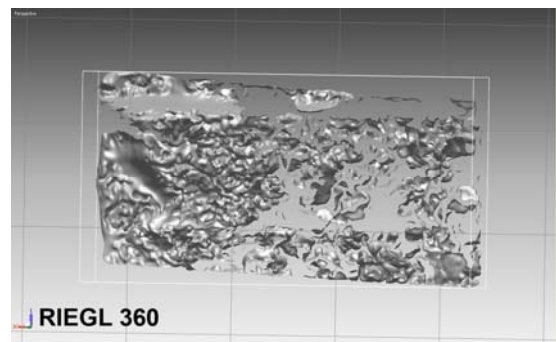

a

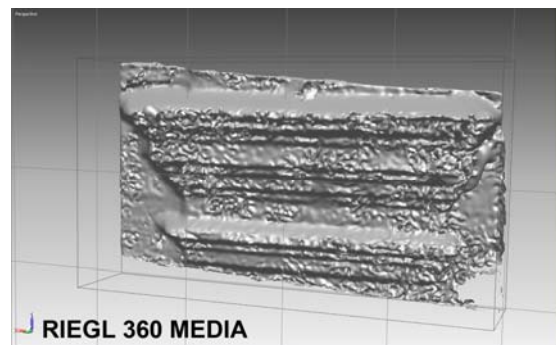

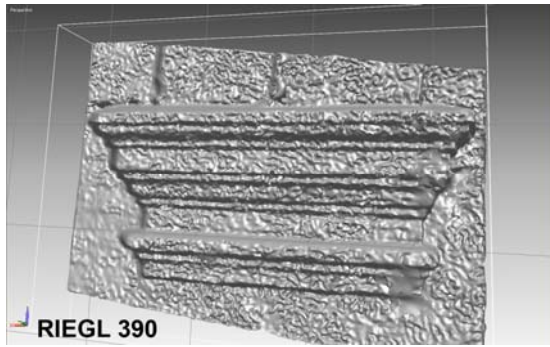

c

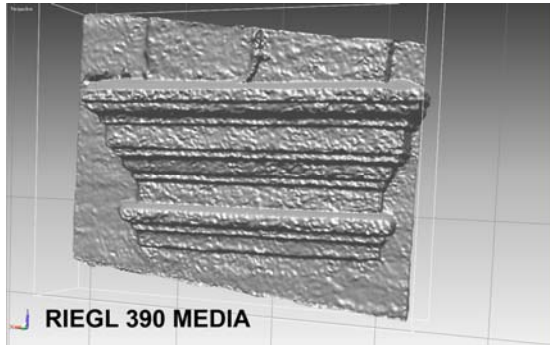

d

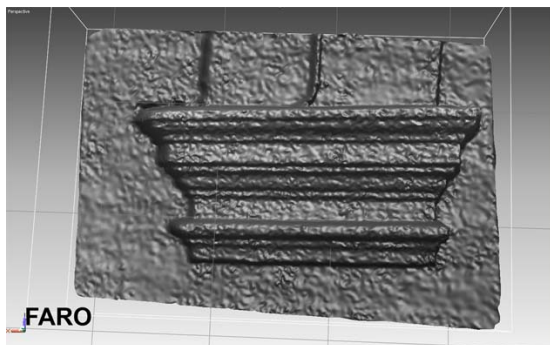

e

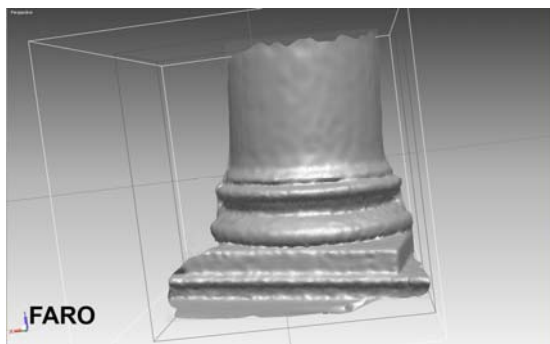

f

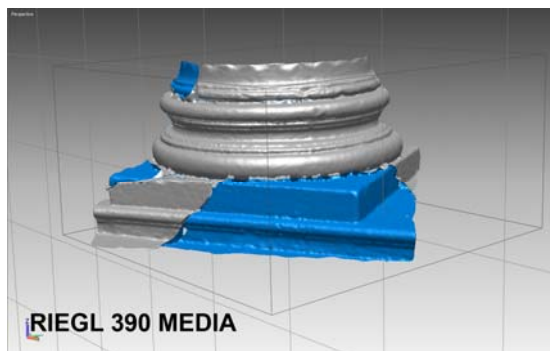

g

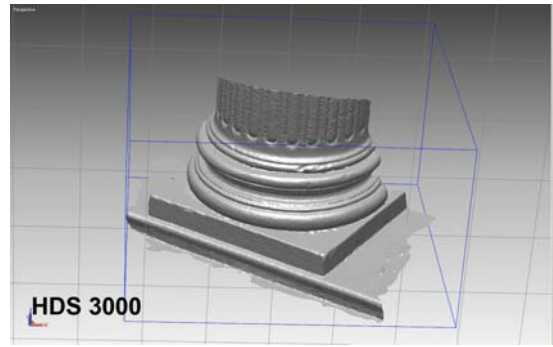

h

Figure 4: Images of corbels (a, b,c, d ,e) and basements (f, g, h)

Observing scans data of the smooth surface test, respect to different points of acquisition, it's easy to see as three-dimensional data are differently characterized by noise. Just to calculate the thickness of points clouds (see tables below), some different parameters have to be considered such as beam's angle of incidence, laser beam focus or materials themselves. It's clear that each laser scanner provides so different results that they can't be compared.

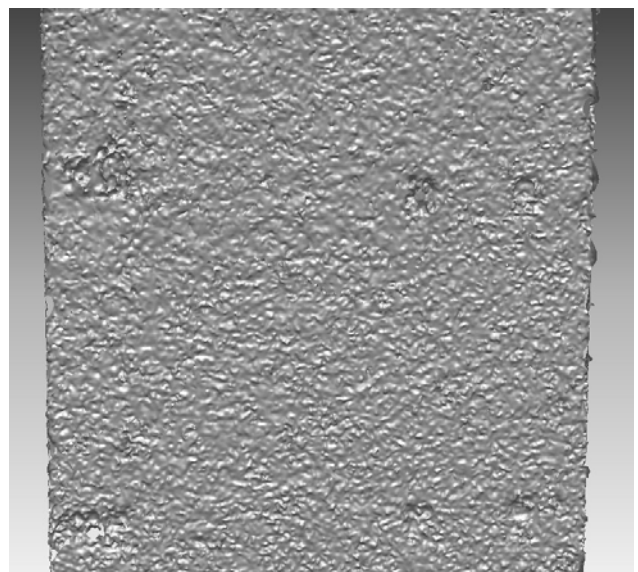
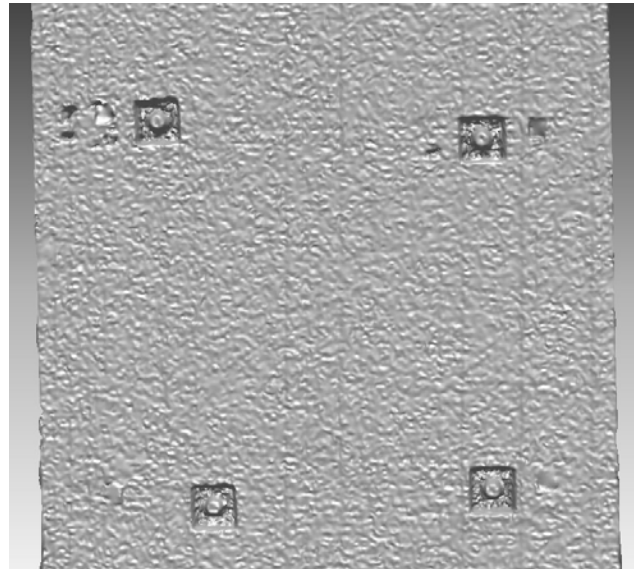

Figure 6: Image of surface (HDS 3000 ; LMS Z 390).

	LMS Z 360 I		HDS 3000	LMS Z 390 I		FARO
	norm	media		norm	media	
Table 90°						
Thickness	0.081	0.023	0.012	0.033	0.011	0.017
Min	-0.072	-0.011	-0.006	-0.051	-0.007	-0.008
Max	0.008	0.012	0.006	-0.018	0.004	0.009
Standard deviation	0.03347	0.0039	0.00192	0.03515	0.00213	0.00235
Table 45°						
Thickness	0.060	0.024	0.016	0.026		0.014
Min	-0.042	-0.011	-0.008	-0.013		-0.007
Max	0.017	0.013	0.007	0.013		0.007
Standard deviation	0.01607	0.0316	0.00178	0.00339		0.00193

Figure 7: The results.

6. CONCLUSIONS

Observing the first results of this test, and in agreement with other published experiences (BOHLER) it's not still possible to find the optimum laser scanner for every architectural survey, because all requested technical characteristics can be present in a same instrument, but, mostly, because it's impossible to apply a rigorous case record in architecture.

Some common characteristics to tested are the operative conditions, such as weight, that is very similar among them, and the power supply.

The Leica's scanner, HDS 3000, is a powerful and versatile systems delivering high accuracy for each measurements (ultra fine scanning and small laser spot), but it requires long time in acquisition, so it can be unsuitable for "fast" surveys.

Moreover it's to observe the absence of suitable raster data, which are necessary both to add a descriptive information to scanned points and to obtain photogrammetric printouts, such as orthophotos.

The Faro's scanner is very accurate too and presents, although it has "phase shift" technology, a high speed in point capture. In architectural survey its main problem is the ranging scan (from 35 to 70 meters): it can be suitable for detail survey but difficultly employed in urban survey.

The Riegl's scanners appear the more complete system, integrating laser technology to photogrammetry. Compared to the others, they present a higher speed and range, but their main limit is that they are very noisy. Considering the two tested systems, the LMS-Z 390 presents better performances, such as range (until 300 meters), the angular accuracy and noise reduction.

References:

L. Peretti, C. Porporato, F. Rinaudo, 2006. La tecnica Lidar e la modellazione 3D di ambienti complessi. Considerazioni operative, in *Atti del Convegno Nazionale Sifet "le nuove frontiere della rappresentazione 3D*, Taranto.

C. Balletti, F. Guerra, P. Vernier, N. Studnicka, J. Riegl, S. Orlandini, 2004. Practical comparative evaluation of an integrated hybrid sensor based on Photogrammetry and Laser Scanning for Architectural Representation, in *ISPRS, International Archives of Photogrammetry and Remote Sensing, Commission V, ISPRS XX Congress, Istanbul, Turchia*.

L. Bornaz, F. Rinaudo, 2004. Terrestrial laser scanner data processing, in *ISPRS, International Archives of Photogrammetry and Remote Sensing, Commission V, ISPRS XX Congress, Istanbul, Turchia*.

D. Barber, J. Mills, P. Bryan, 2004. Towards a standard specification for terrestrial laser scanning of cultural heritage - one year on, in *ISPRS, International Archives of Photogrammetry and Remote Sensing, Commission V, ISPRS XX Congress, Istanbul, Turchia*.

L. Bornaz, A. Lingua, F. Rinaudo, 2003. Multiple scan registration in LIDAR close range applications, in *ISPRS Commission V, WGV/4 proceedings- Ancona*.

G. Bitelli, 2002. Rilievo di beni architettonici, in *Atti della 6° Conferenza Nazionale ASITA Geomatica per l'ambiente, il territorio e il patrimonio culturale*, Perugia.

Boehler W., Heinz G., Marbs A.; 2001 *The potential of non-contact close range laser scanner for cultural heritage recording*. In International Archives Of The Photogrammetry, Remote Sensing and Spatial Information Sciences. vol. XXXIV-5/C7.

Boehler W. 2003 *Comparing different laser scanners: features, resolution, accuracy*. In CISM, International Centre for Mechanical Sciences, Udine.